

Aug.1.2024 Copyright 2024 HIROSE ELECTRIC CO., LTD. All Rights Reserved.  
In case of consideration for using Automotive equipment / device which demand high reliability, kindly contact our sales window correspondents.

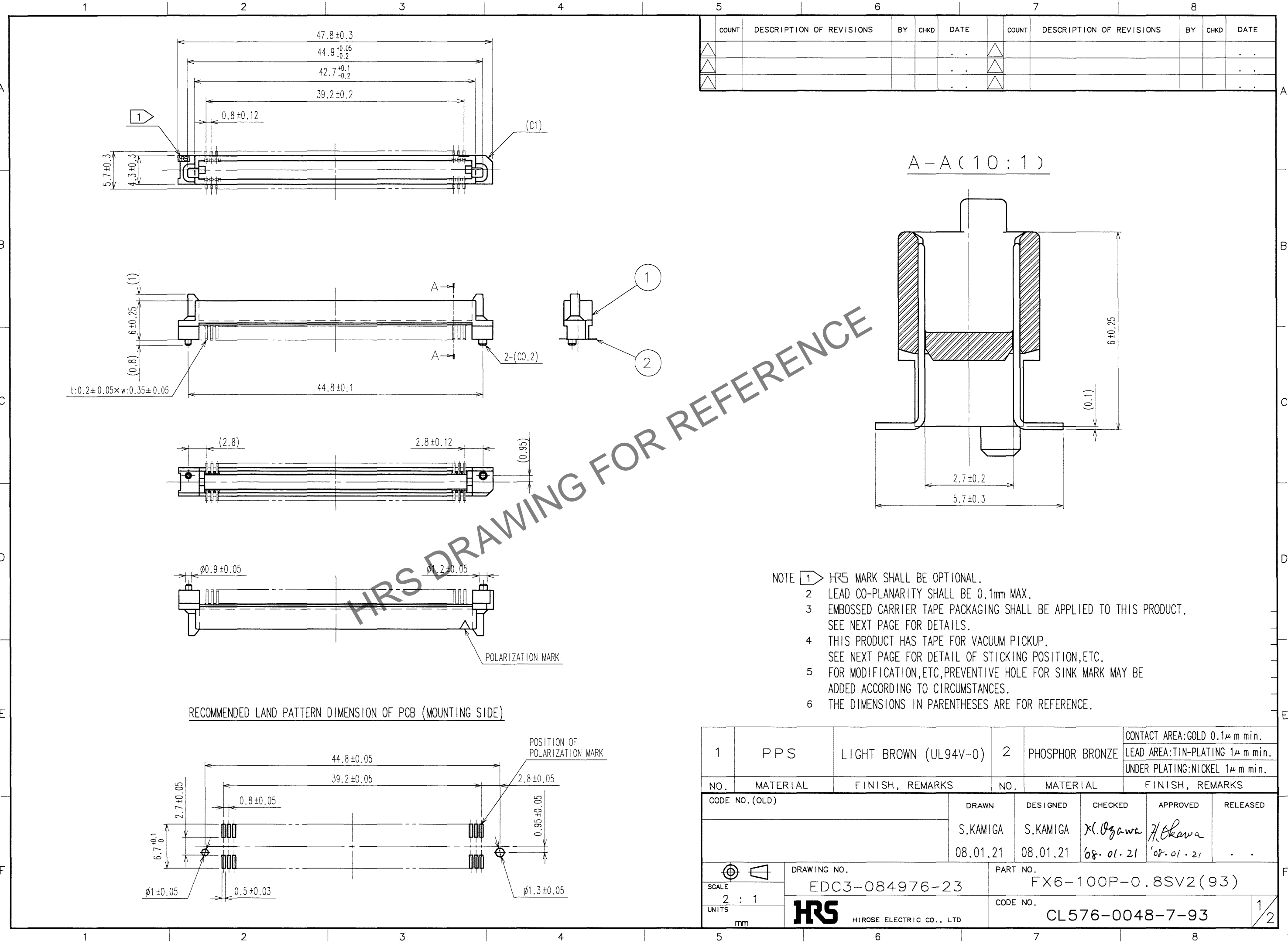

COUNT	DESCRIPTION OF REVISIONS	BY	CHKD	DATE	COUNT	DESCRIPTION OF REVISIONS	BY	CHKD	DATE
△				..	△				..
△				..	△				..
△				..	△				..

- NOTE
- 1 ▷ HRS MARK SHALL BE OPTIONAL.
  - 2 LEAD CO-PLANARITY SHALL BE 0.1mm MAX.
  - 3 EMBOSSED CARRIER TAPE PACKAGING SHALL BE APPLIED TO THIS PRODUCT. SEE NEXT PAGE FOR DETAILS.
  - 4 THIS PRODUCT HAS TAPE FOR VACUUM PICKUP. SEE NEXT PAGE FOR DETAIL OF STICKING POSITION, ETC.
  - 5 FOR MODIFICATION, ETC, PREVENTIVE HOLE FOR SINK MARK MAY BE ADDED ACCORDING TO CIRCUMSTANCES.
  - 6 THE DIMENSIONS IN PARENTHESES ARE FOR REFERENCE.

RECOMMENDED LAND PATTERN DIMENSION OF PCB (MOUNTING SIDE)

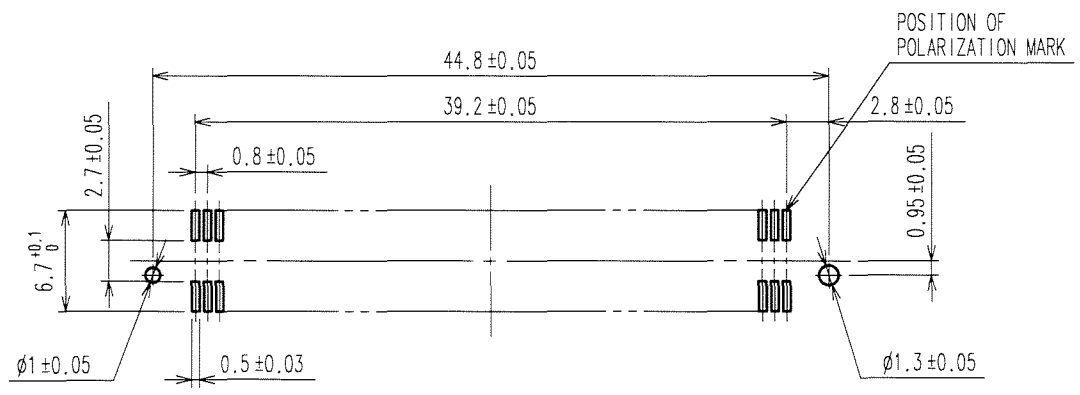

1	PPS	LIGHT BROWN (UL94V-0)	2	PHOSPHOR BRONZE	CONTACT AREA: GOLD 0.1μm min. LEAD AREA: TIN-PLATING 1μm min. UNDER PLATING: NICKEL 1μm min.
NO.	MATERIAL	FINISH, REMARKS	NO.	MATERIAL	FINISH, REMARKS
CODE NO. (OLD)			DRAWN	DESIGNED	CHECKED
			S.KAMIGA	S.KAMIGA	X. Ogawa
			08.01.21	08.01.21	08.01.21
			APPROVED	RELEASED	
			H. Okawa		
			08.01.21	08.01.21	
DRAWING NO.			PART NO.		
EDC3-084976-23			FX6-100P-0.8SV2(93)		
UNITS			CODE NO.		
mm			CL576-0048-7-93		
					1/2

TO

Aug.1.2024 Copyright 2024 HIROSE ELECTRIC CO., LTD. All Rights Reserved.  
In case of consideration for using Automotive equipment / device which demand high reliability, kindly contact our sales window correspondents.

COUNT	DESCRIPTION OF REVISIONS	BY	CHKD	DATE	COUNT	DESCRIPTION OF REVISIONS	BY	CHKD	DATE

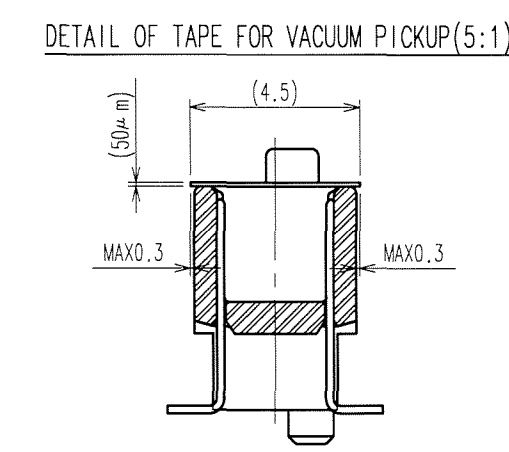
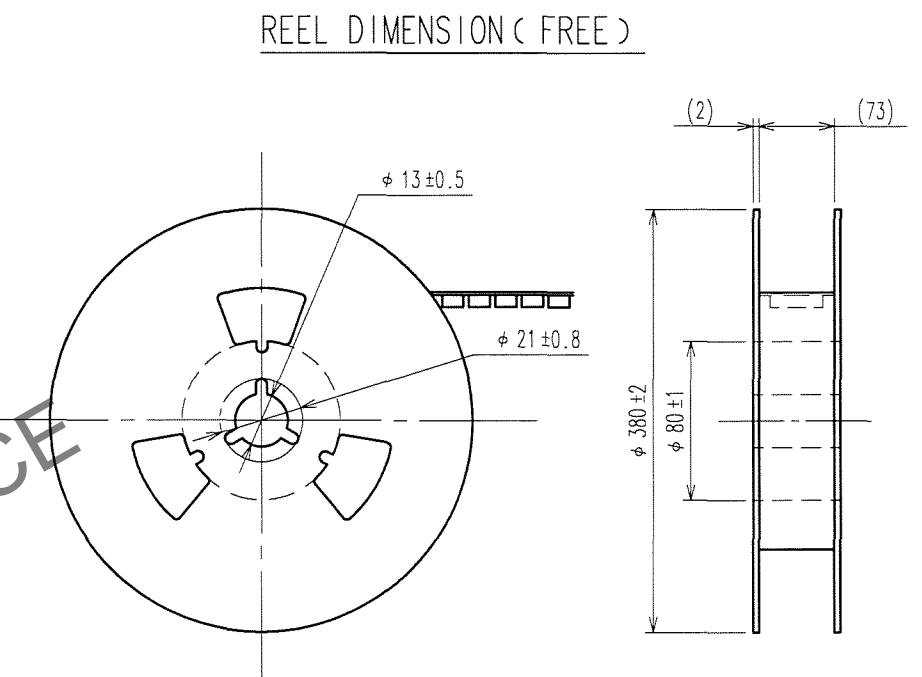
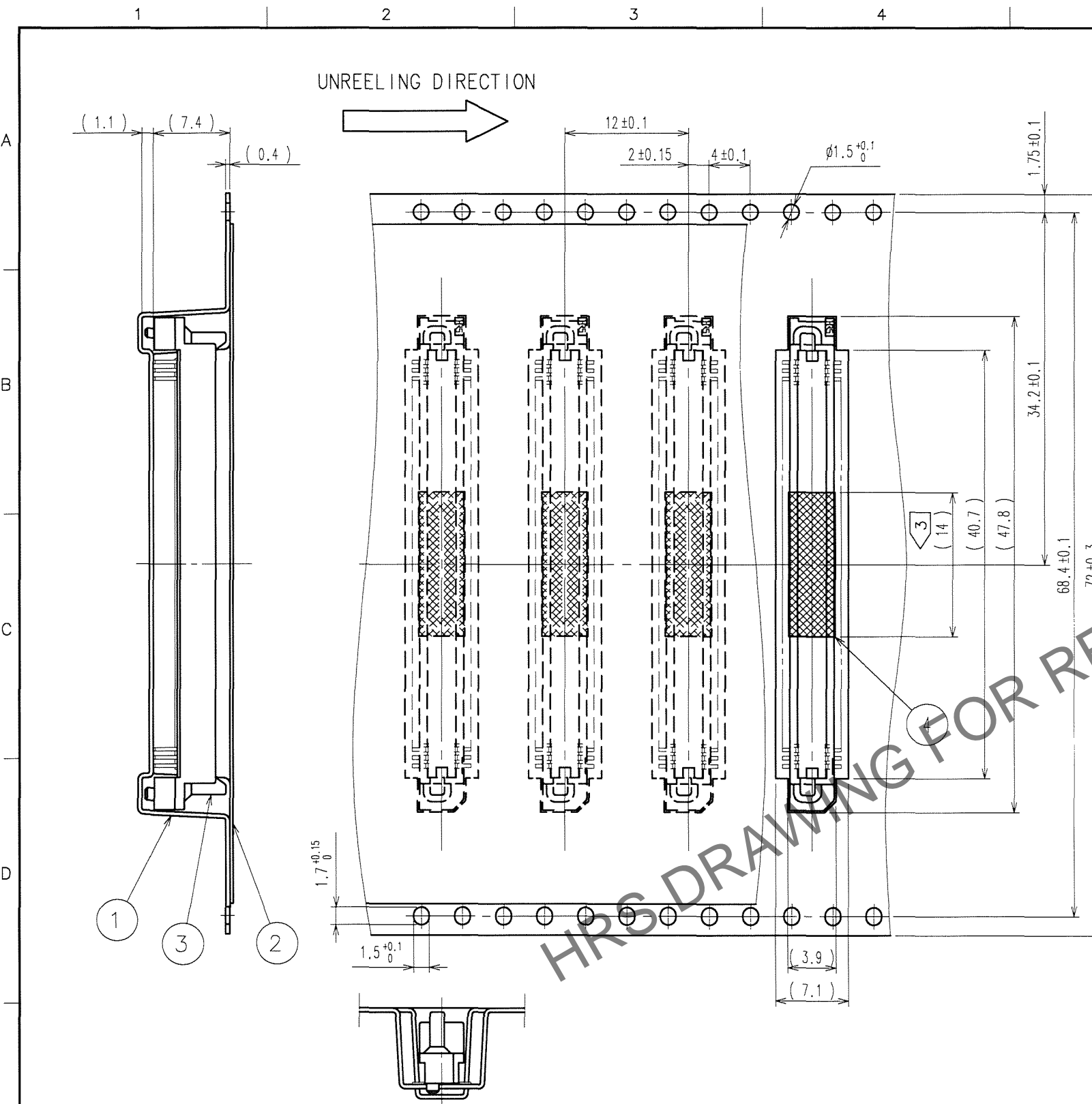

NOTE 1 1 REEL : 1000 CONNECTORS.  
 2 THE DIMENSIONS IN PARENTHESES ARE FOR REFERENCE.  
 3 REMOVE THE VACUUM PICKUP TAPE AFTER MOUNTING THE CONNECTOR.

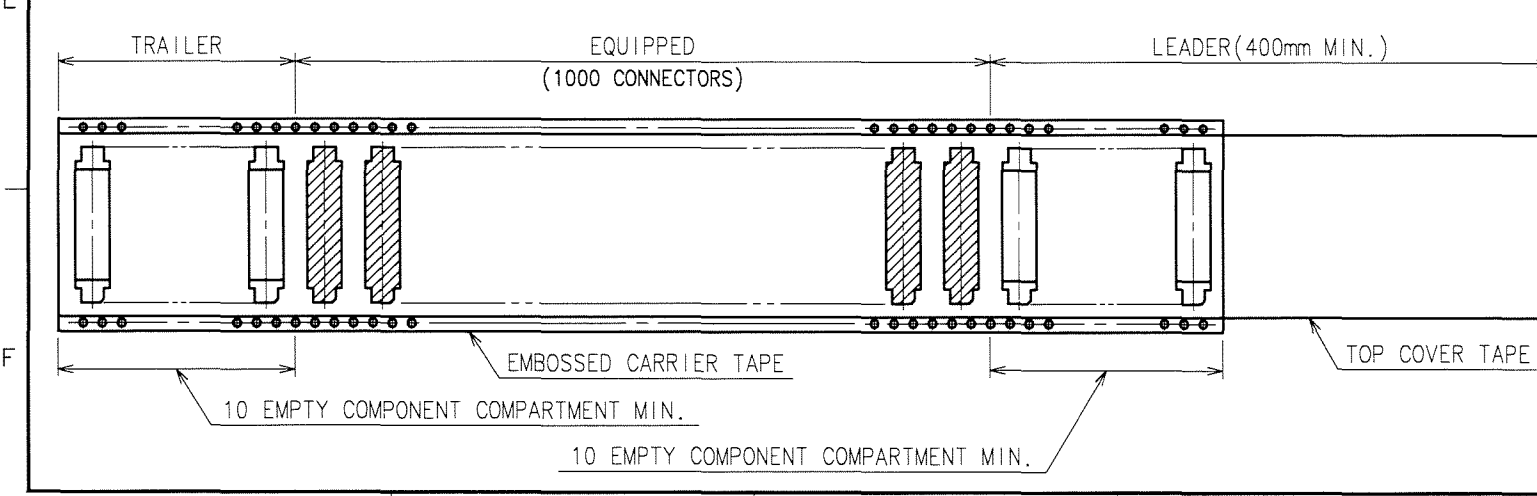

2	POLYESTER	(TOP COVER TAPE)	4	POLYIMIDE	(TAPE FOR VUCUUM PICKUP)
1	POLYSTYRENE	(EMBOSSED CARRIER TAPE)	3		(CONNECTOR)
NO.	MATERIAL	FINISH, REMARKS	NO.	MATERIAL	FINISH, REMARKS
CODE NO. (OLD)			DRAWN	DESIGNED	CHECKED
			S.KAMIGA	S.KAMIGA	H. Ogawa
			08.01.21	08.01.21	08-01-21
				H. Okawa	08-01-21
DRAWING NO.			PART NO.		
EDC3-084976-23			FX6-100P-0.8SV2(93)		
UNITS			CODE NO.		
mm			CL576-0048-7-93		

TO