

Dec.1.2024 Copyright 2024 HIROSE ELECTRIC CO., LTD. All Rights Reserved.
In case of consideration for using Automotive equipment / device which demand high reliability, kindly contact our sales window correspondents.

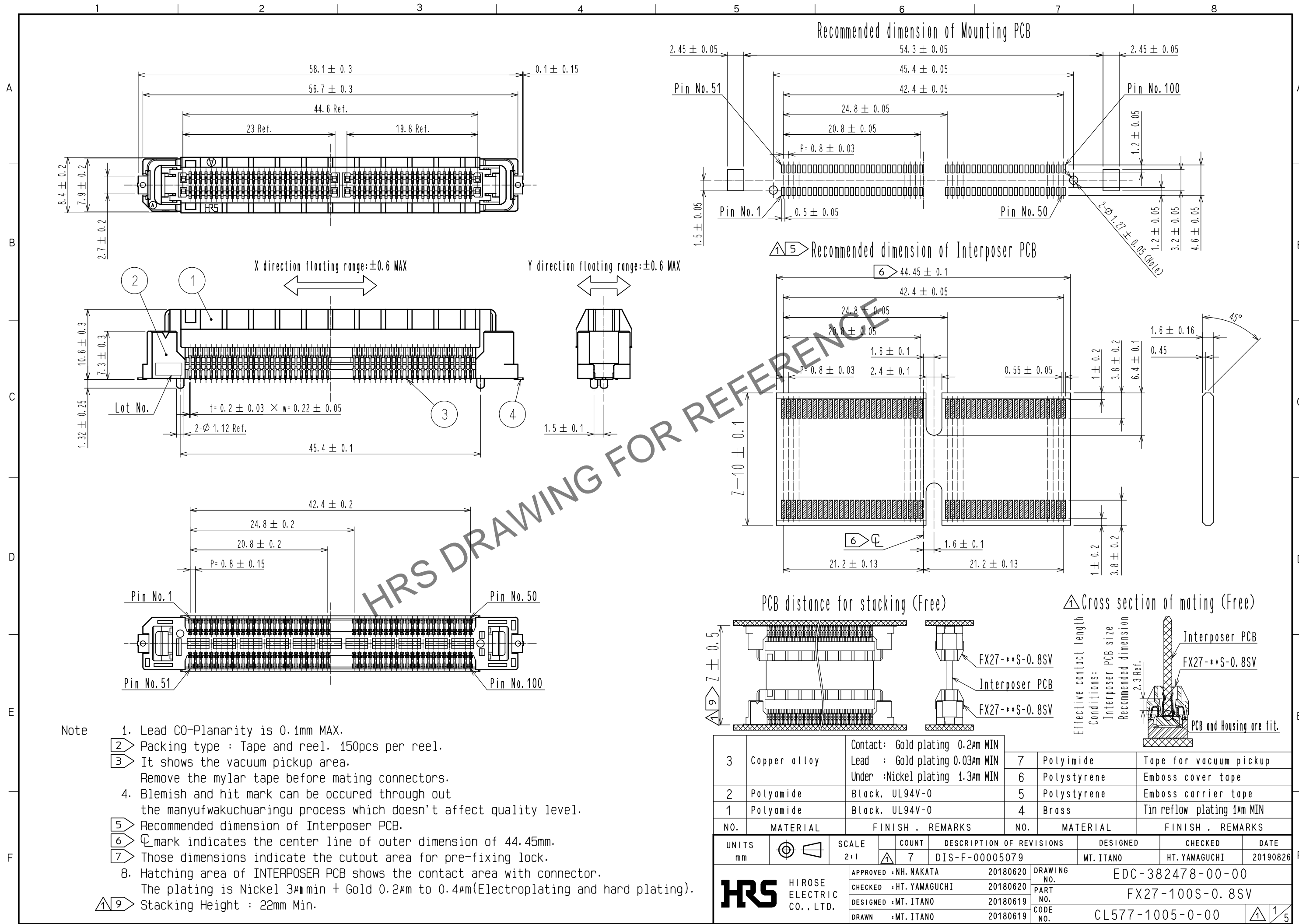

NO.	MATERIAL	FINISH . REMARKS	NO.	MATERIAL	FINISH . REMARKS
3	Copper alloy	Contact: Gold plating 0.2μm MIN Lead : Gold plating 0.03μm MIN Under :Nickel plating 1.3μm MIN	7	Polyimide	Tape for vacuum pickup
2	Polyamide	Black. UL94V-0	6	Polystyrene	Emboss cover tape
1	Polyamide	Black. UL94V-0	5	Polystyrene	Emboss carrier tape
			4	Brass	Tin reflow plating 1μm MIN

UNITS	SCALE	COUNT	DESCRIPTION OF REVISIONS	DESIGNED	CHECKED	DATE
mm	2:1	7	DIS-F-00005079	MT. ITANO	HT. YAMAGUCHI	20190826

APPROVED	DATE	DRAWING NO.
•NH. NAKATA	20180620	EDC-382478-00-00
CHECKED	DATE	PART NO.
•HT. YAMAGUCHI	20180620	FX27-100S-0.8SV
DESIGNED	DATE	CODE NO.
•MT. ITANO	20180619	CL577-1005-0-00
DRAWN	DATE	
•MT. ITANO	20180619	

Dec.1.2024 Copyright 2024 HIROSE ELECTRIC CO., LTD. All Rights Reserved.
 In case of consideration for using Automotive equipment / device which demand high reliability, kindly contact our sales window correspondents.

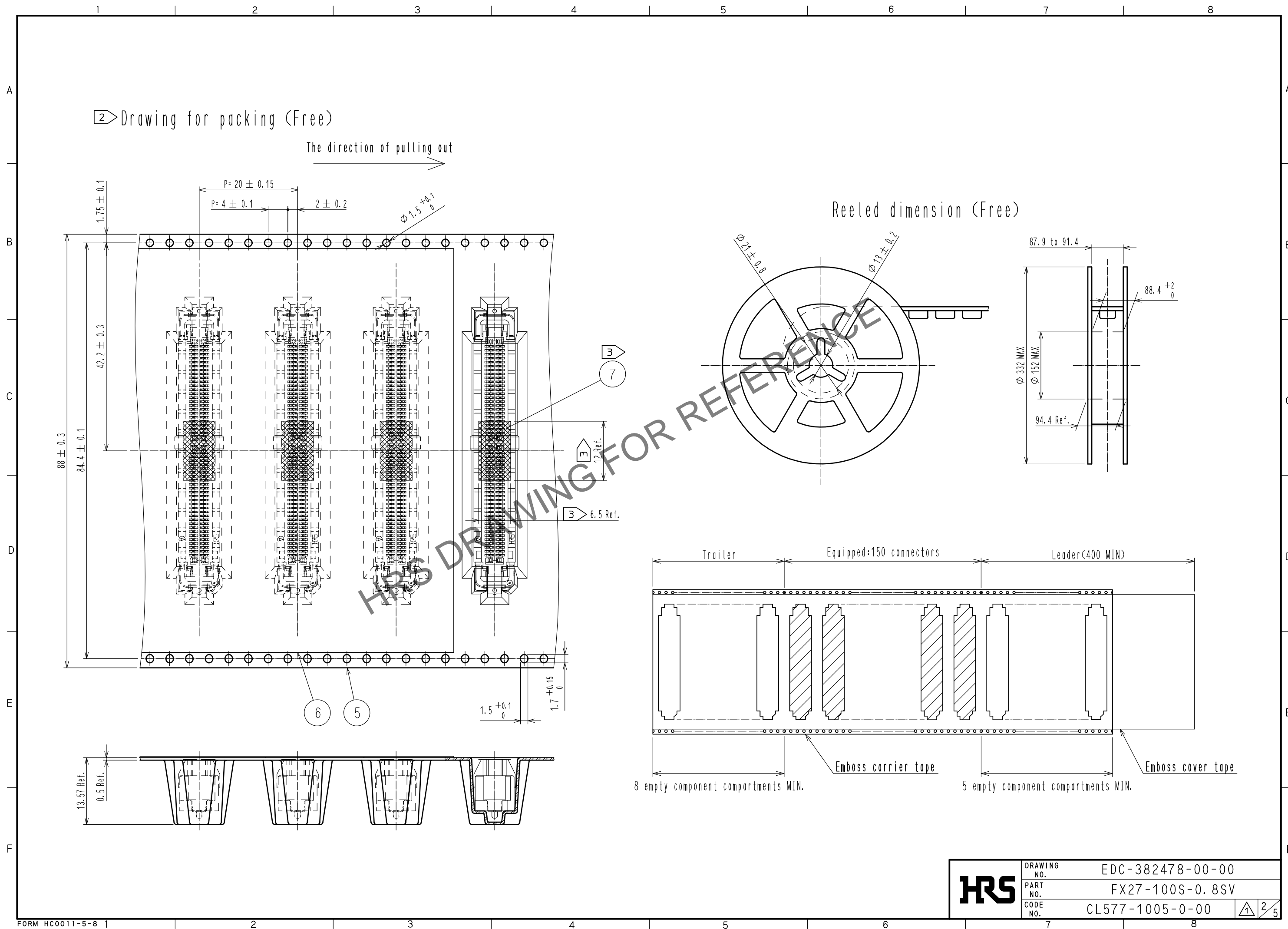

HRS	DRAWING NO.	EDC-382478-00-00
	PART NO.	FX27-100S-0.8SV
	CODE NO.	CL577-1005-0-00
		① 2/5

Dec.1.2024 Copyright 2024 HIROSE ELECTRIC CO., LTD. All Rights Reserved.
 In case of consideration for using Automotive equipment / device which demand high reliability, kindly contact our sales window correspondents.

7 Simple Lock for Initial Insertion and Removal (Free)

The notches provided in the mating PCB Interposer are used to lock the connection engaged with the locking latch of the connector.

40pos., 60pos. PCB Interposer 80pos., 100pos., 120pos. PCB Interposer

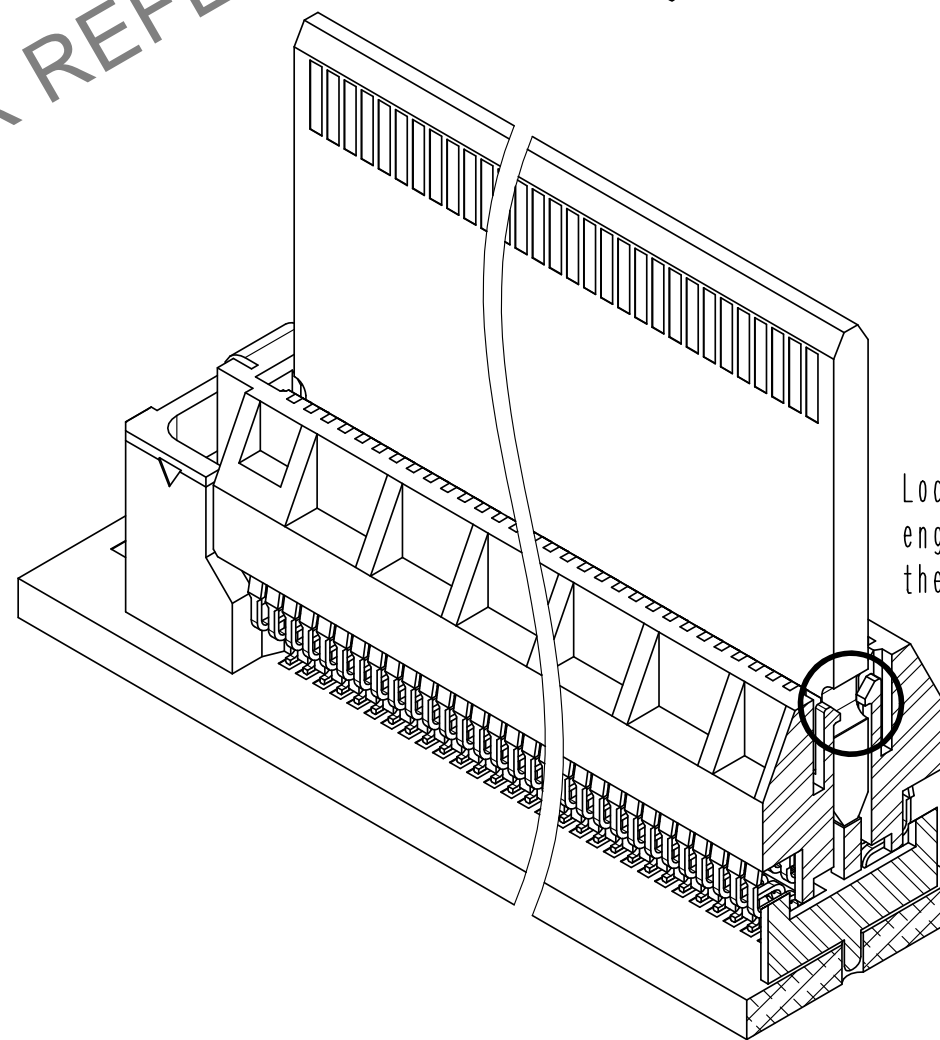
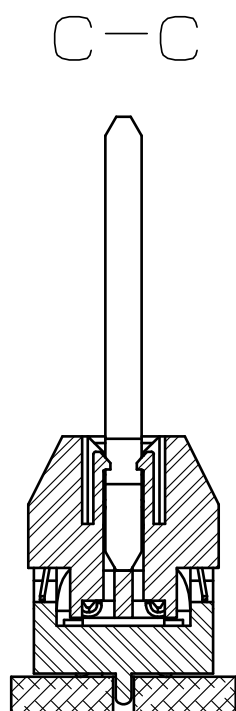
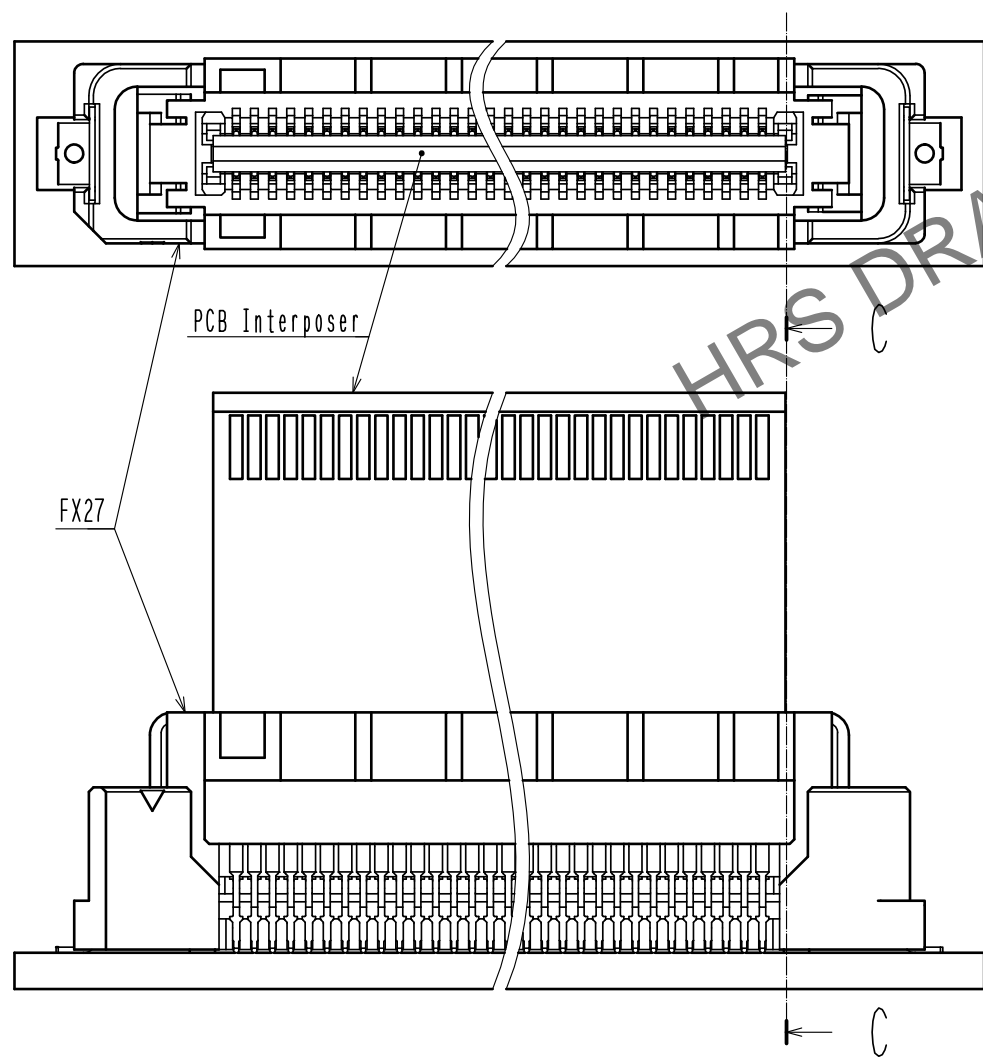
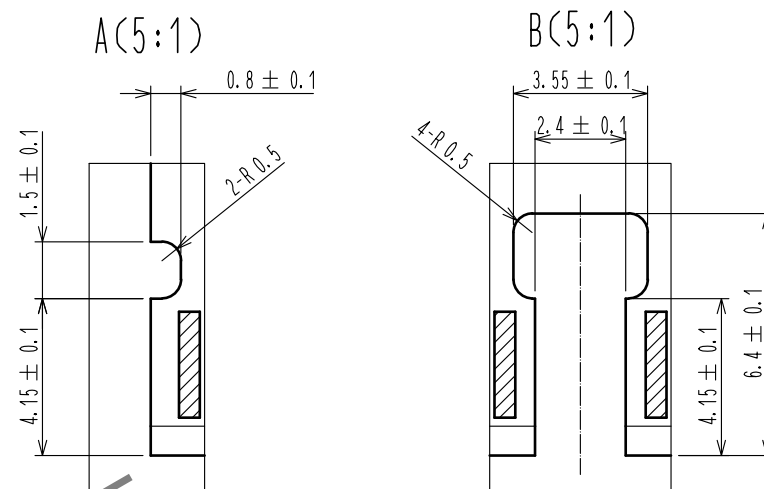
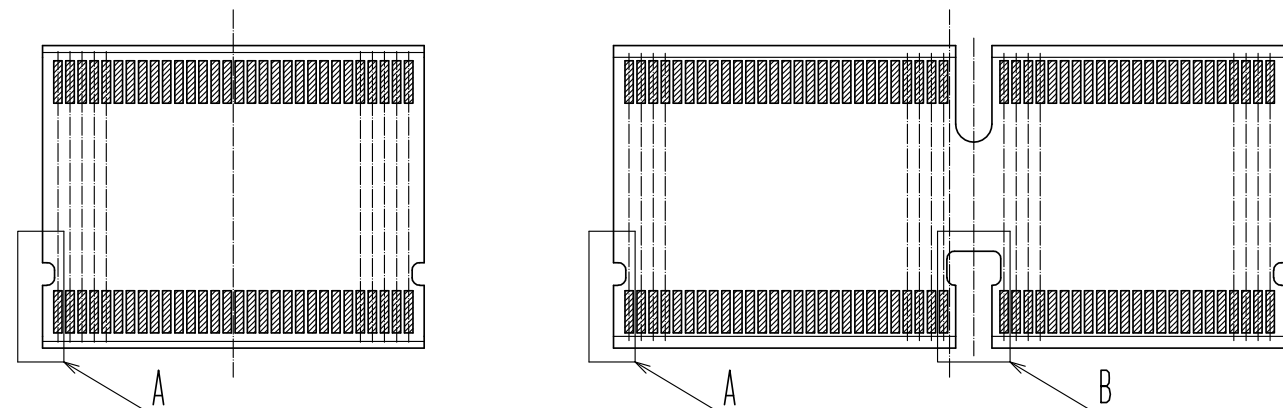

Locking latch of the connector is engaged with the notch of the PCB Interposer.

HRS DRAWING FOR REFERENCE

HRS	DRAWING NO.	EDC-382478-00-00	3/5
	PART NO.	FX27-100S-0.8SV	
	CODE NO.	CL577-1005-0-00	

Dec.1.2024 Copyright 2024 HIROSE ELECTRIC CO., LTD. All Rights Reserved.
 In case of consideration for using Automotive equipment / device which demand high reliability, kindly contact our sales window correspondents.

△Pin Assignment

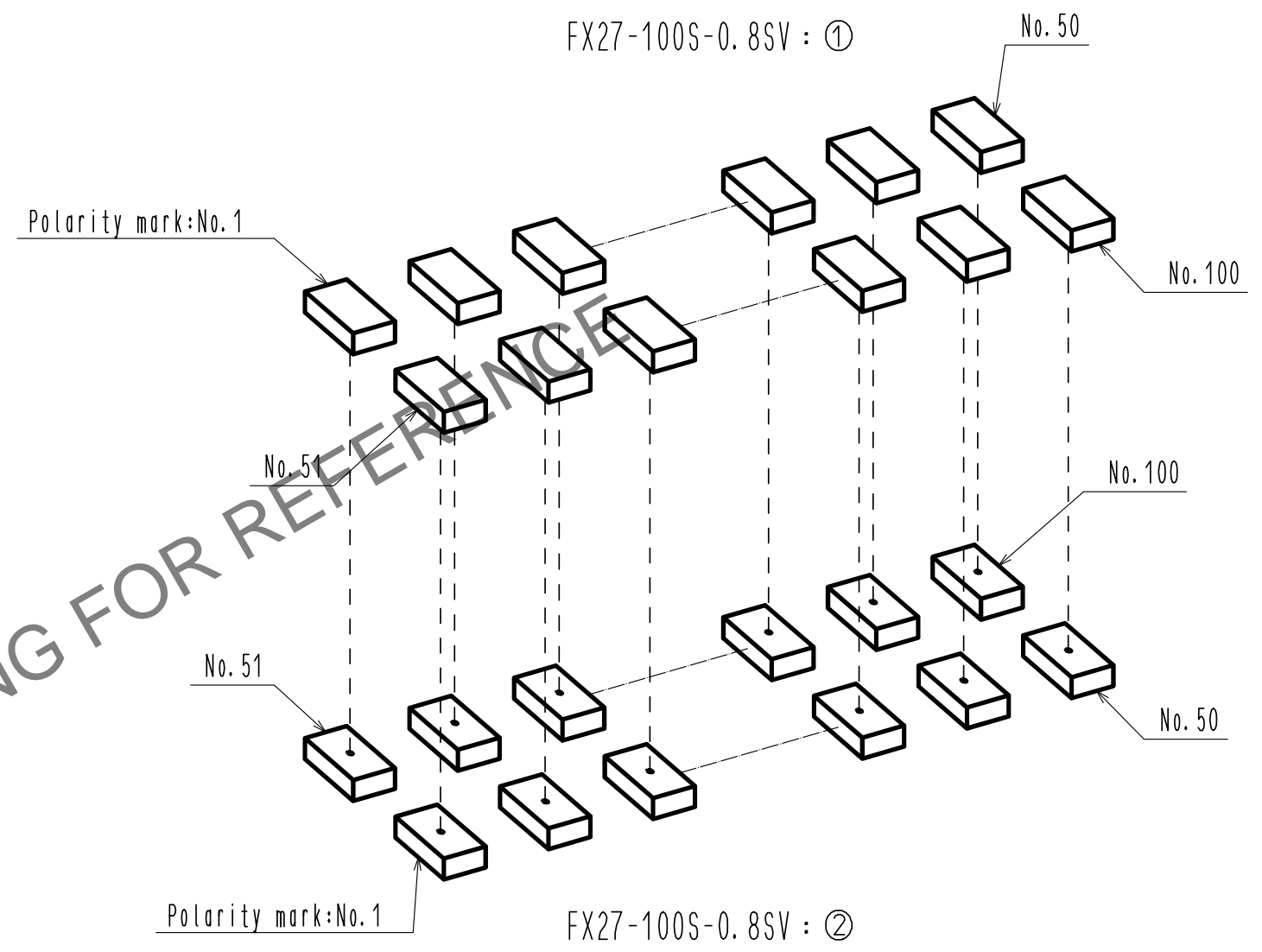
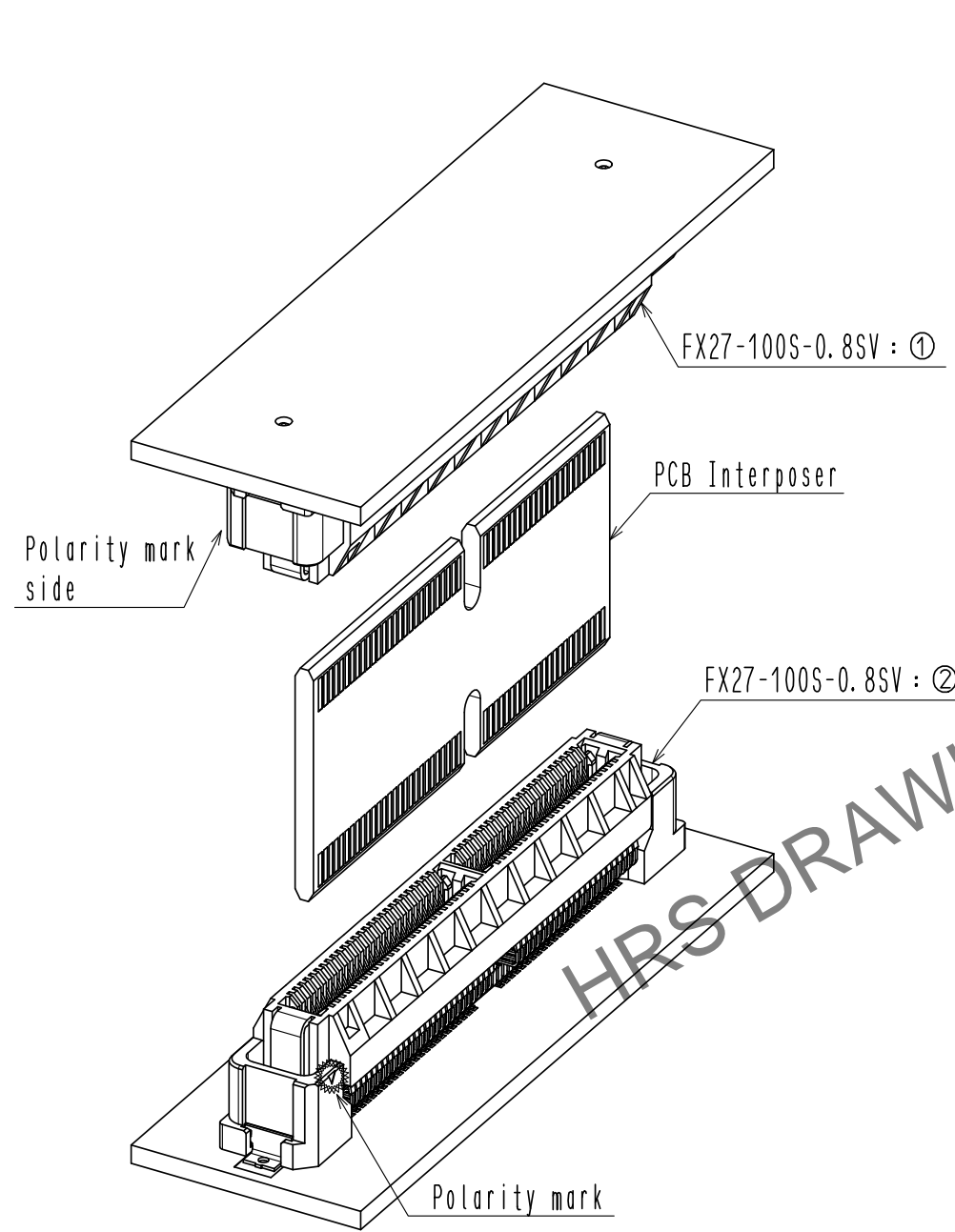

When the connector is used as shown in the sketch to the above,
 the polarity mark of FX27-100S-0.8SV of ① and ② are reversed.
 Attention should be paid to the pin assignment of the circuits on the board.

HRS	DRAWING NO.	EDC-382478-00-00	4/5
	PART NO.	FX27-100S-0.8SV	
	CODE NO.	CL577-1005-0-00	

Dec.1.2024 Copyright 2024 HIROSE ELECTRIC CO., LTD. All Rights Reserved.
In case of consideration for using Automotive equipment / device which demand high reliability, kindly contact our sales window correspondents.

△ PCB supports

This connector can absorb misalignment of PCB but cannot absorb vibration itself.
When PCB are supported by a connector only, the connector will be loaded excessively,
which may result in a damage or contact failure.
Take measures to secure PCB with an object other than connector as shown in the following figure.

If the spacer is installed away from the connector, the PCB may bend and the connector may not be securely mated.
Fit the spacer after the connector securely mated.

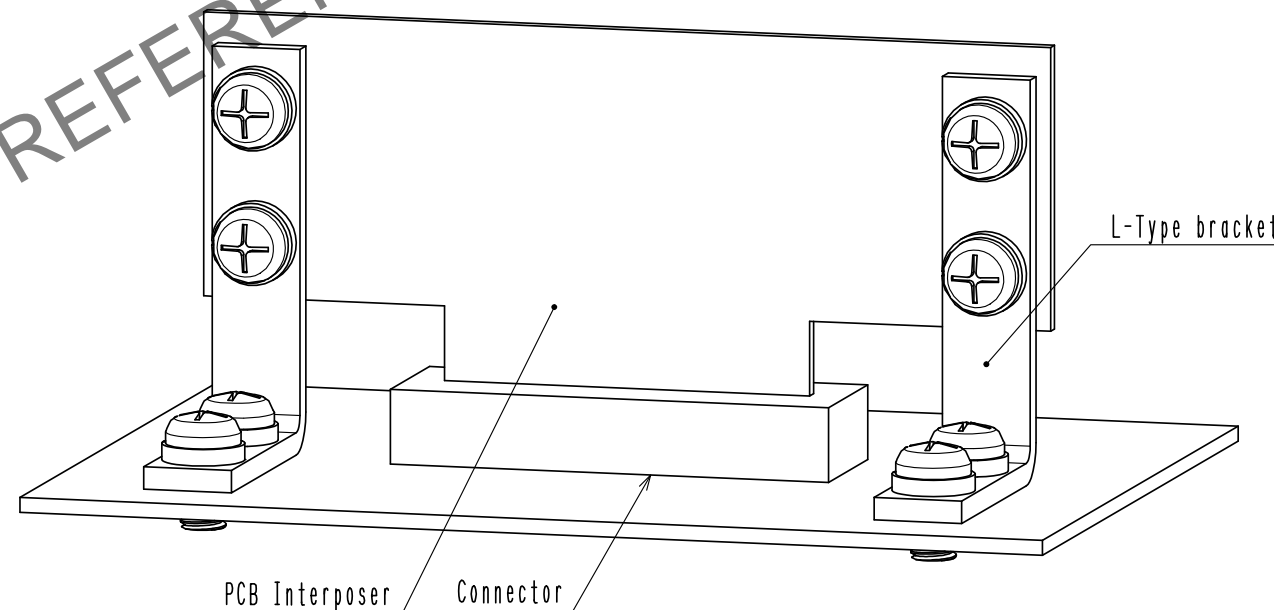
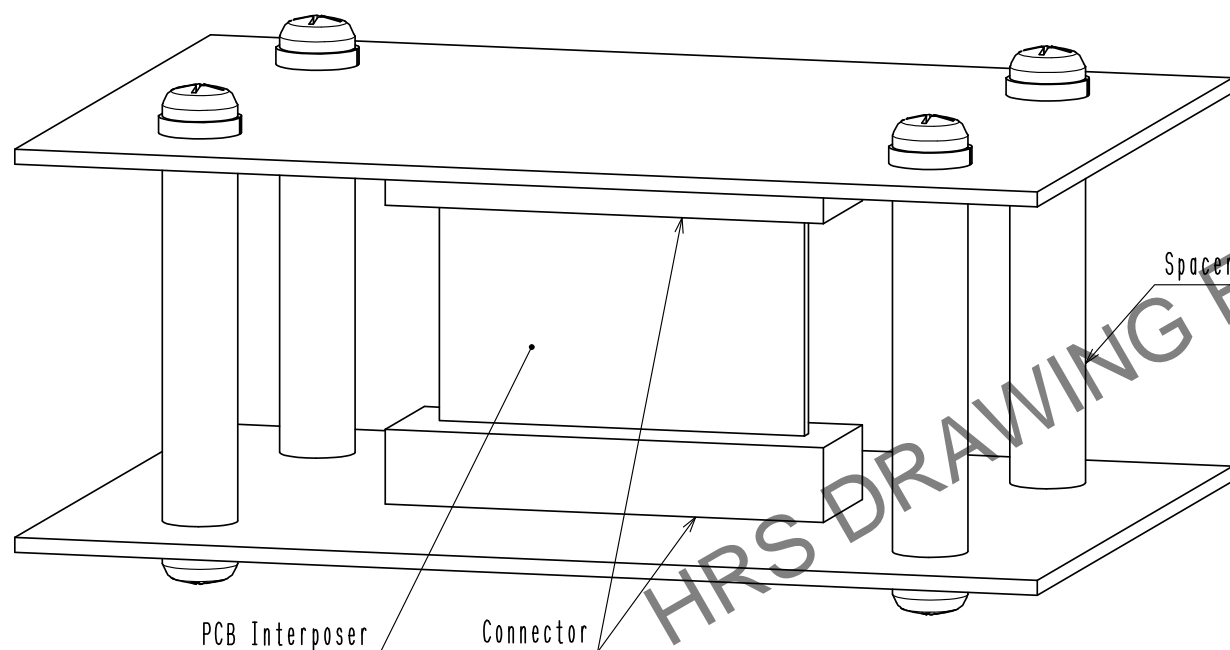

HRS	DRAWING NO.	EDC-382478-00-00
	PART NO.	FX27-100S-0.8SV
	CODE NO.	CL577-1005-0-00
		△ 5/5