

Jan.1.2025 Copyright 2025 HIROSE ELECTRIC CO., LTD. All Rights Reserved.
In case of consideration for using Automotive equipment / device which demand high reliability, kindly contact our sales window correspondents.

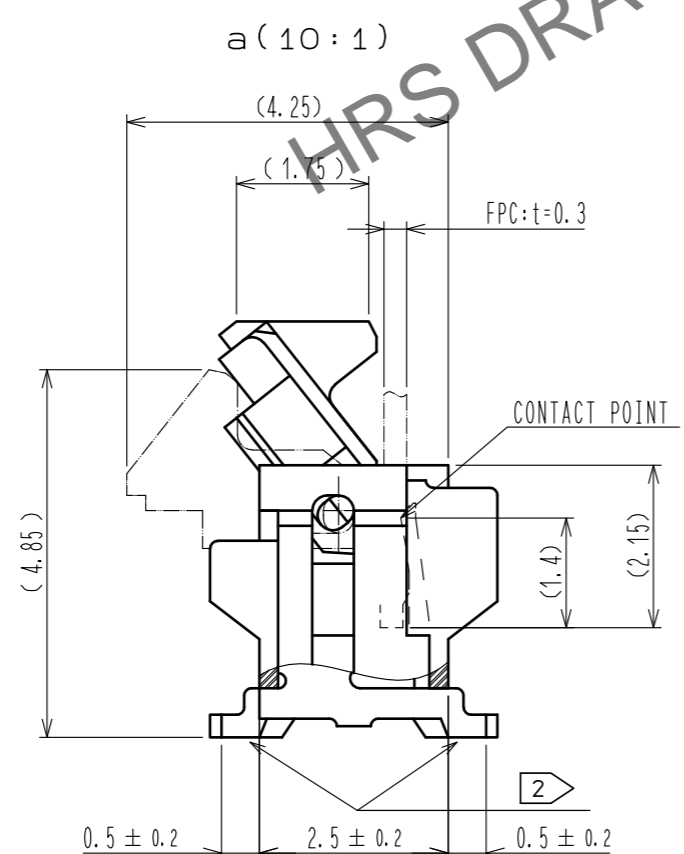
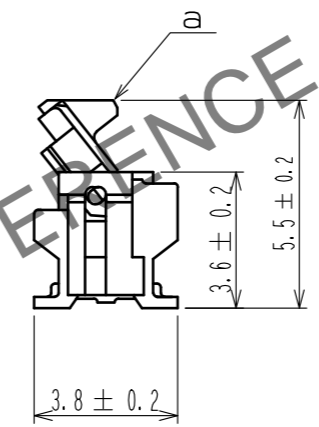
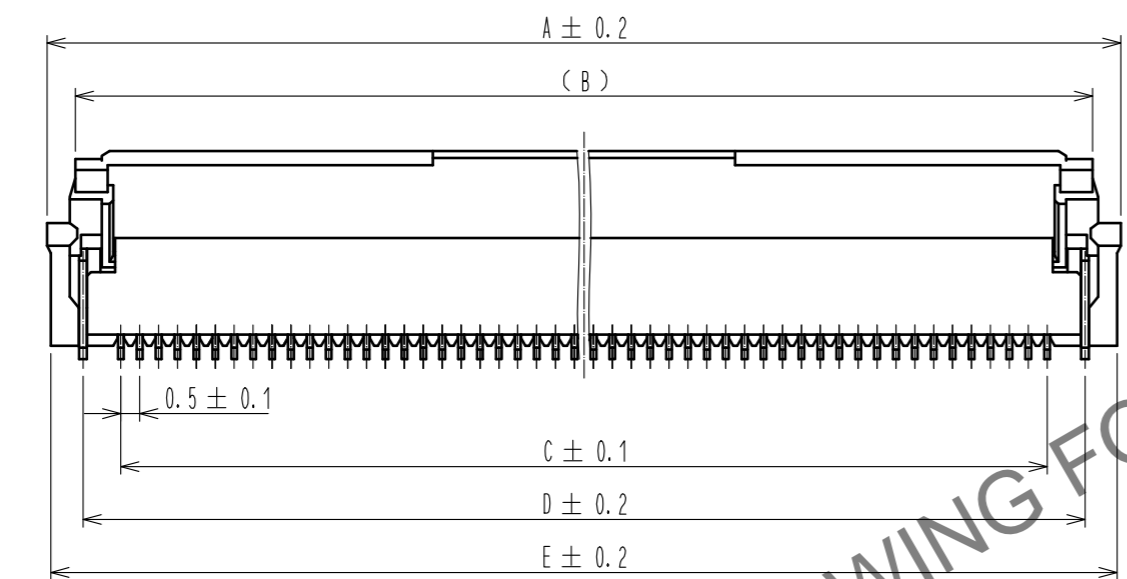
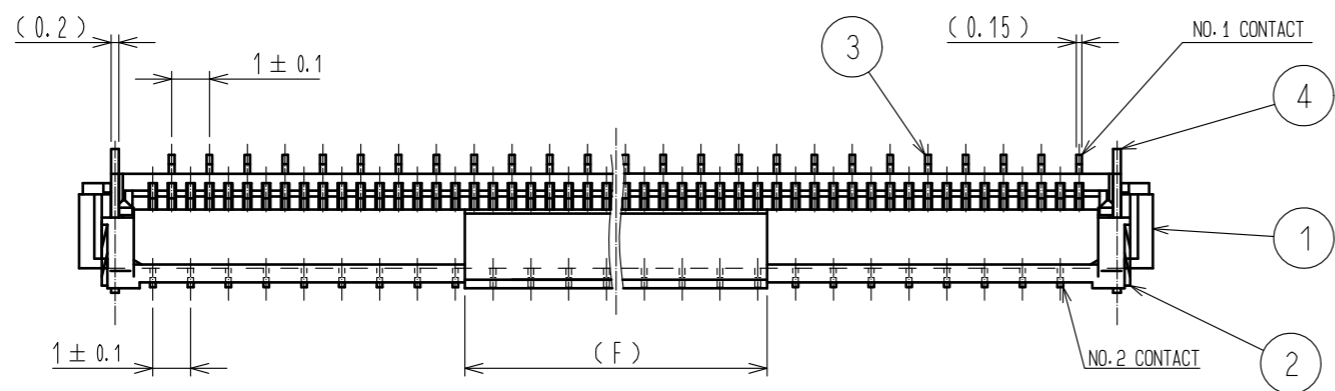

- NOTE 1 THE DIMENSIONS IN PARENTHESES ARE FOR REFERENCE.
 2 LEAD CO-PLANARITY SHALL BE 0.1 MAX.
 3 SEE DIMENSION TABLE IN THE APPENDIX.
 4 MATERIAL
- | NUMBER OF CONTACTS | MATERIAL |
|--------------------|-----------|
| 60 | LCP |
| OTHER | POLYAMIDE |
- 5 DIFFERENCES OF THE GOLD PLATED AREA DO NOT INFLUENCE ON THE PRODUCT PERFORMANCE.
 6 'n' REPRESENTS THE NUMBER OF CONTACTS.
 7 The quality remains good. Even with the dark spots, which could occasionally occur molded plastics.

4	BRASS	TIN PLATING 1μm MIN-OVER NICKEL 1μm MIN.			
3	PHOSPHOR BRONZE	(CONTACT AREA, LEAD) GOLD PLATING 0.05μmMIN OVER NICKEL 1μmMIN (OTHER) NICKEL PLATING 1μmMIN	8	(CONNECTOR)	
2	PPS	(DEEP BROWN) UL94V-0	7	POLYSTYRENE	
1	4	(BEIGE) UL94V-0	6	POLYESTER	
			5	POLYSTYRENE	
NO.	MATERIAL	FINISH . REMARKS	NO.	MATERIAL	FINISH . REMARKS
UNITS	mm	SCALE	5 : 1	COUNT	16
DESCRIPTION OF REVISIONS			DESIGNED	CHECKED	DATE
DIS-F-00013777			HN. UCHIUMI	KN. SHIBUYA	20220509
APPROVED : HS. SAKAMOTO		20140215	DRAWING NO. EDC3-159266-03		
CHECKED : HS. SAKAMOTO		20140215	PART NO. FH12-**S-0.5SVA(54)		
DESIGNED : RT. IKEDA		20140213	CODE NO. CL586		
DRAWN : NM. SANPEI		20140212	1/9		

Jan.1.2025 Copyright 2025 HIROSE ELECTRIC CO., LTD. All Rights Reserved.
In case of consideration for using Automotive equipment / device which demand high reliability, kindly contact our sales window correspondents.

RECOMMENDED PCB MOUNTING PATTERN

NUMBER OF CONTACTS: EVEN NUMBER

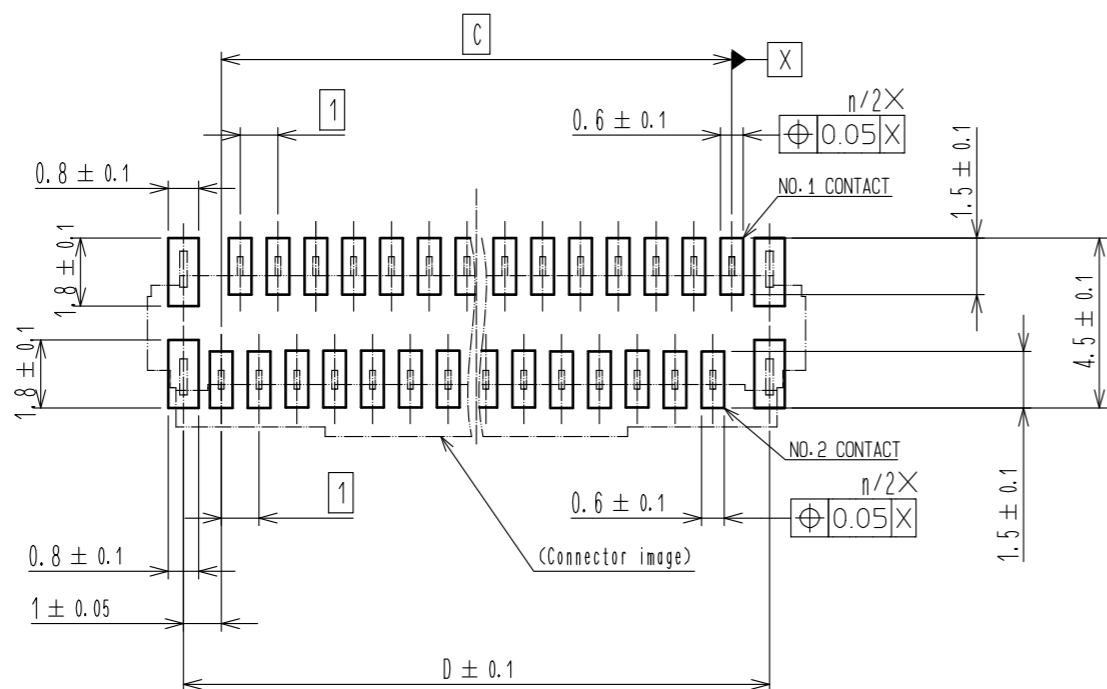

NUMBER OF CONTACTS: ODD NUMBER

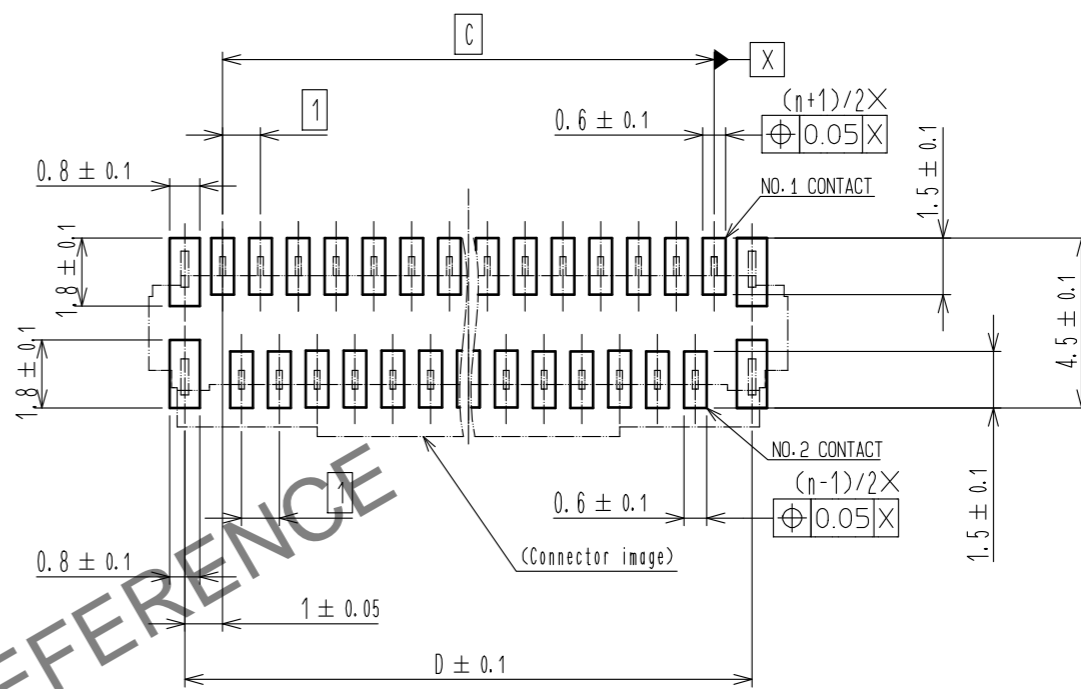

RECOMMENDED STENCIL PATTERN (RECOMMENDED STENCIL THICKNESS: t=0.15)

NUMBER OF CONTACTS: EVEN NUMBER

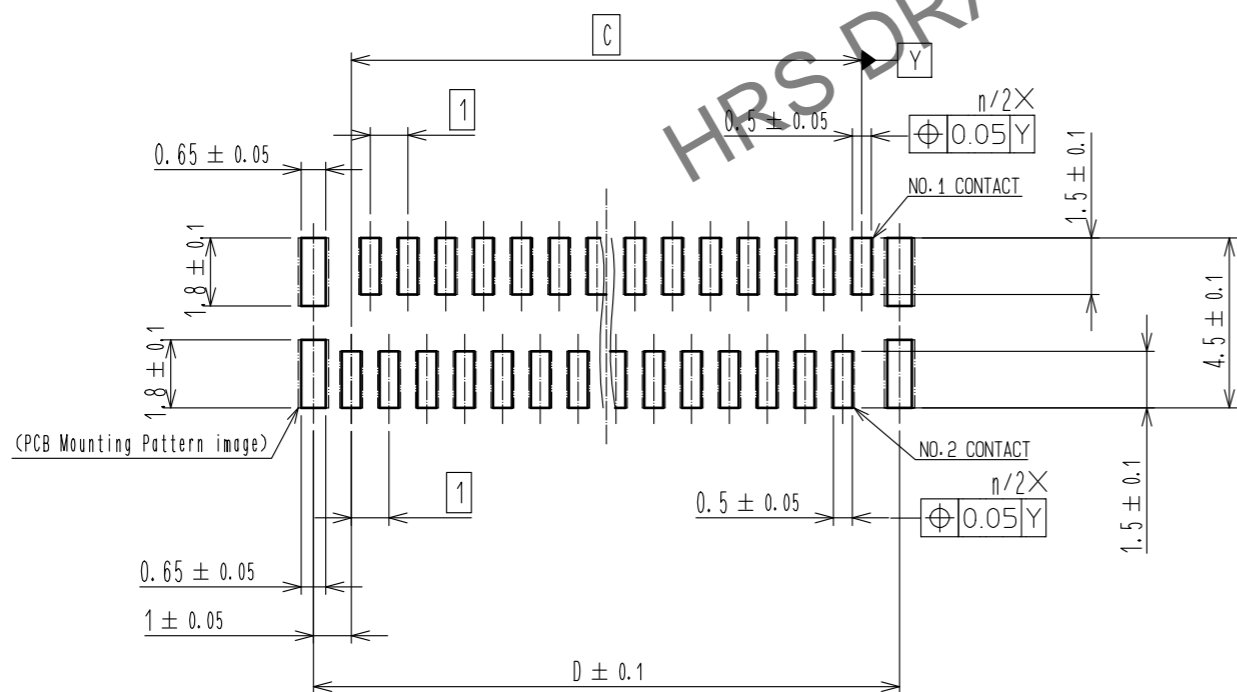

NUMBER OF CONTACTS: ODD NUMBER

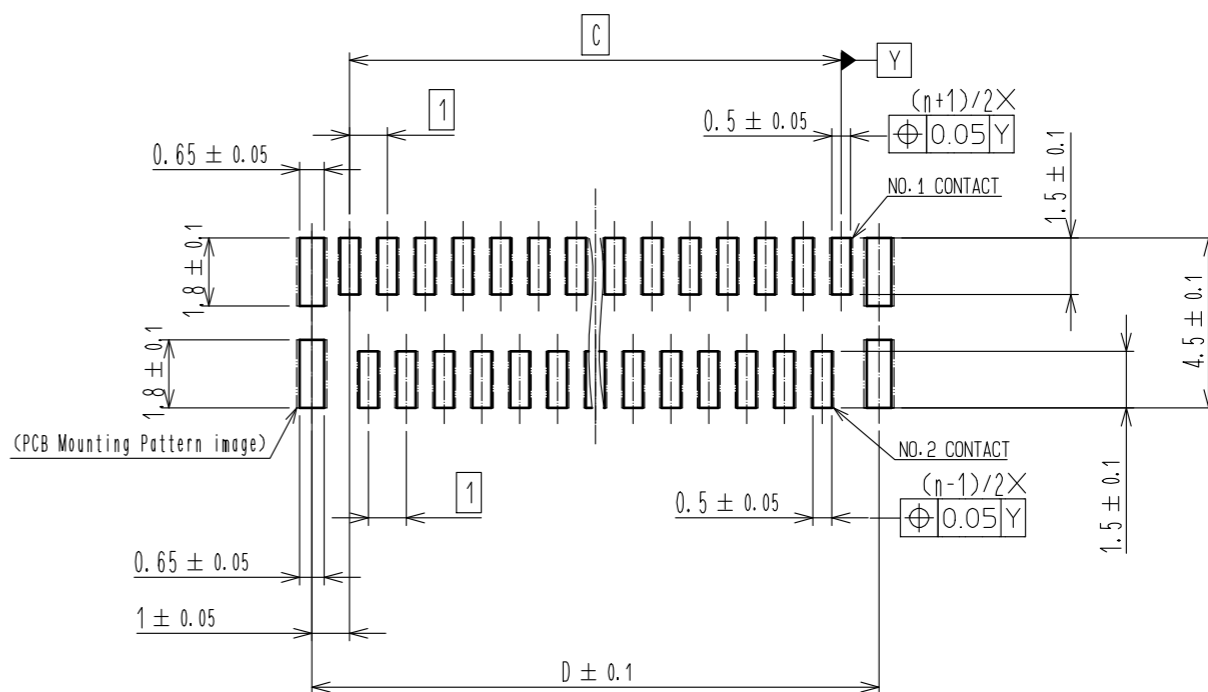

HRS	DRAWING NO.	EDC3-159266-03
	PART NO.	FH12-**S-0.5SVA(54)
	CODE NO.	CL586
		2/9

Jan.1.2025 Copyright 2025 HIROSE ELECTRIC CO., LTD. All Rights Reserved.
In case of consideration for using Automotive equipment / device which demand high reliability, kindly contact our sales window correspondents.

RECOMMENDED FPC/FFC (15:1)

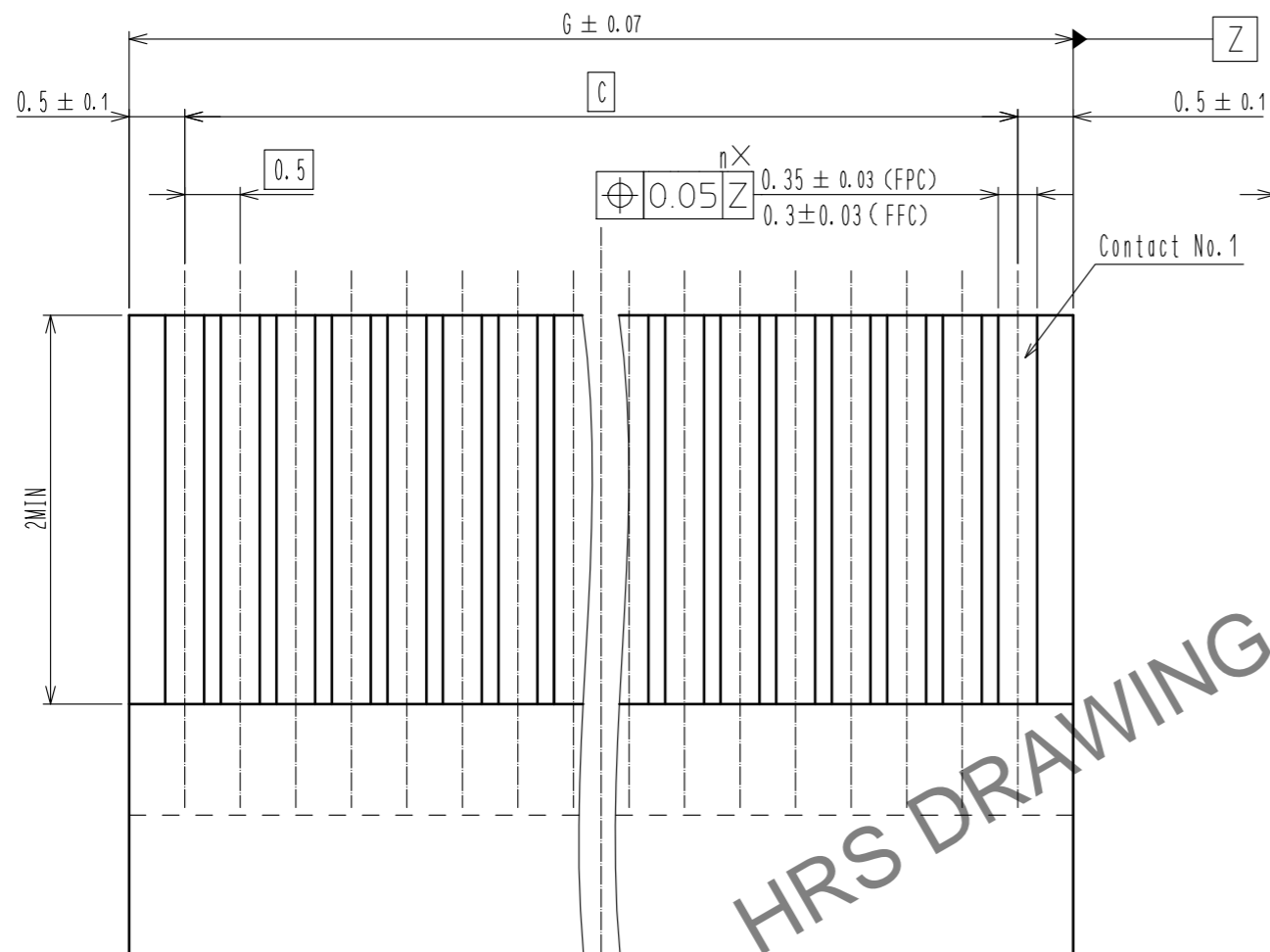

NOTE deleted

FPC CONFIGURATION (REFERENCE EXAMPLE) (SCALE:FREE)

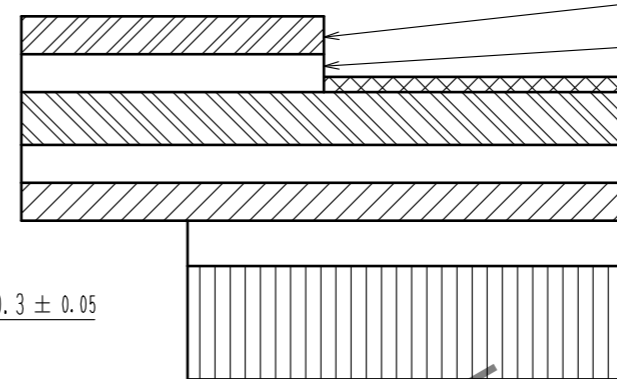

MATERIAL NAME	MATERIAL	THICKNESS(μm)
COVERING FILM LAYER	POLYIMIDE 1mil thick.	(25)
COVER ADHESIVE		(25)
SURFACE TREATMENT	NICKEL UNDERCOAT 1 to 5μm + GOLD PLATING 0.2μm	3
COPPER FOIL	CU 1 oz	35
BASE ADHESIVE	HEAT-HARDENED ADHESIVE	25
BASE FILM	POLYIMIDE 1mil thick	25
REINFORCEMENT MATERIAL ADHESIVE	HEAT-HARDENED ADHESIVE	30
STIFFENER FILM	POLYIMIDE 7mil thick	175

FFC CONFIGURATION (REFERENCE EXAMPLE) (SCALE:FREE)

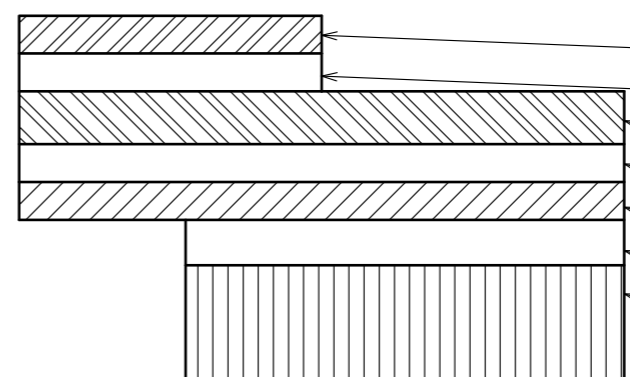

MATERIAL NAME	MATERIAL	THICKNESS(μm)
POLYESTER FILM		(12)
ADHESIVE	THERMOPLASTIC POLYESTER	(30)
GOLD PLATED SOFT COPPER FILM		35
ADHESIVE	POLYESTER	30
POLYESTER		12
ADHESIVE	POLYESTER	30
STIFFENER FILM	POLYESTER	188

HRS

DRAWING NO.	EDC3-159266-03
PART NO.	FH12-**S-0.5SVA(54)
CODE NO.	CL586

3/9

Jan.1.2025 Copyright 2025 HIROSE ELECTRIC CO., LTD. All Rights Reserved.
 In case of consideration for using Automotive equipment / device which demand high reliability, kindly contact our sales window correspondents.

EMBOSSED CARRIER TAPE DIMENSION (2:1)

TAPE WIDTH : 32mm MIN

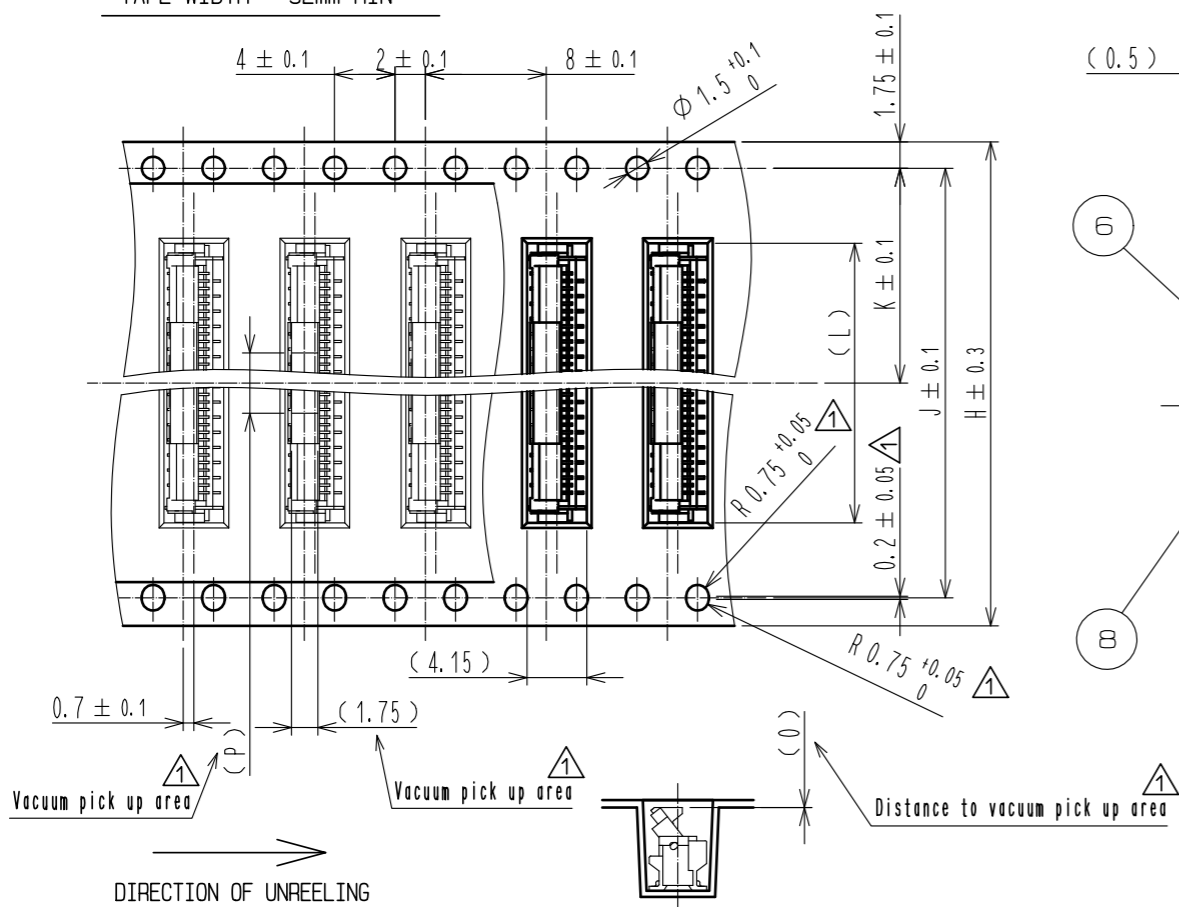

REEL DIMENSION(SHOW AS BELOW)(FREE)

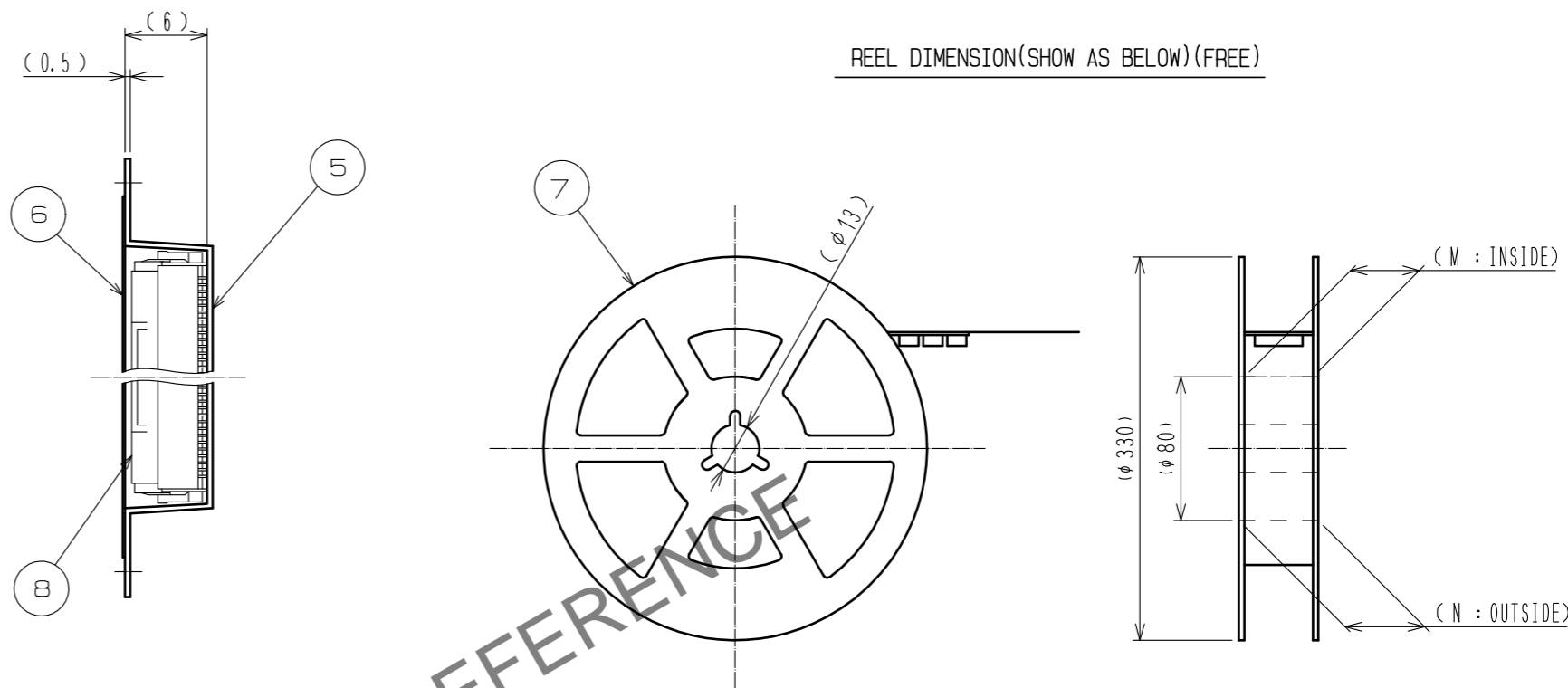

TAPE WIDTH : 24mm MAX

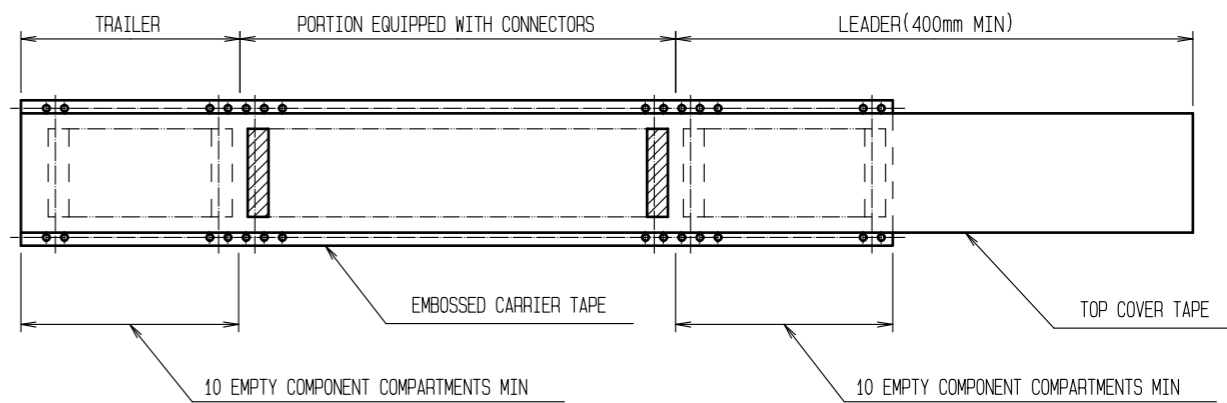
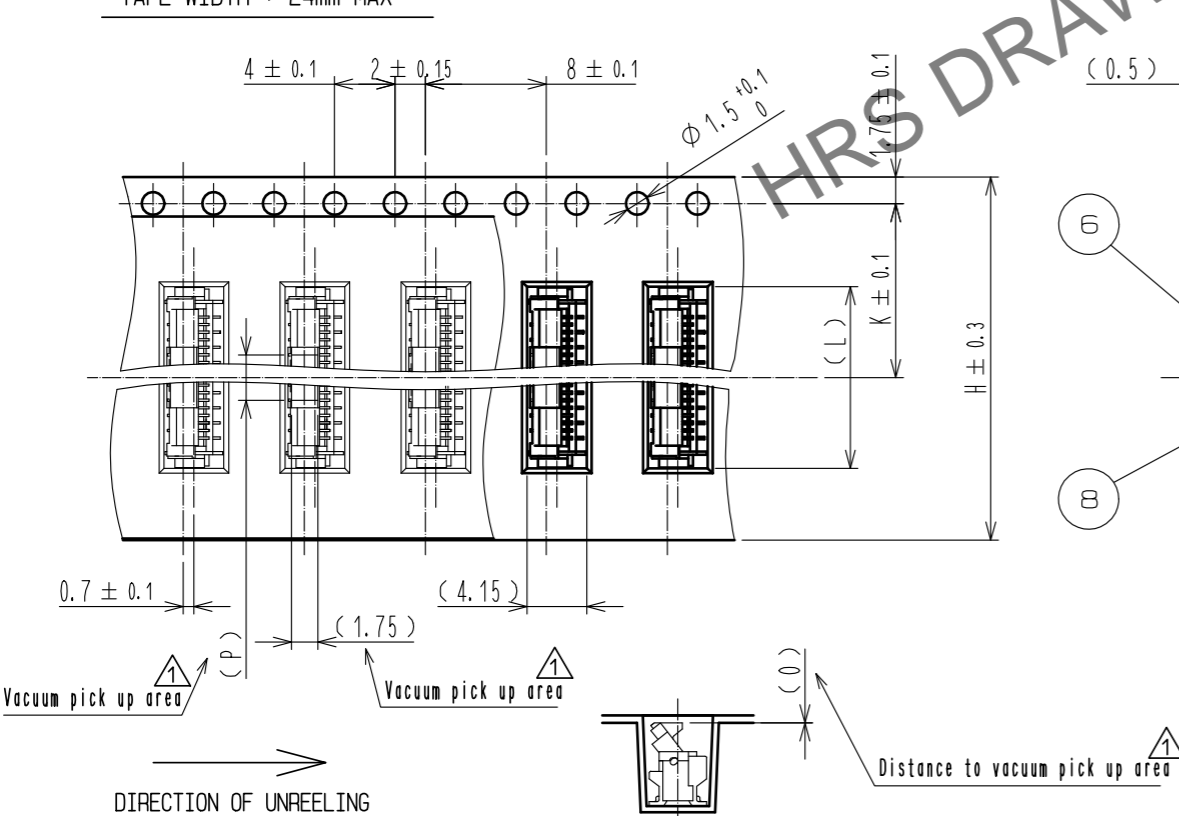

NOTE 8 1REEL : 1000 CONNECTORS.

DRAWING FOR PACKING

HRS	DRAWING NO.	EDC3-159266-03
	PART NO.	FH12-**S-0.5SVA(54)
	CODE NO.	CL586
		4/9

Jan.1.2025 Copyright 2025 HIROSE ELECTRIC CO., LTD. All Rights Reserved.
In case of consideration for using Automotive equipment / device which demand high reliability, kindly contact our sales window correspondents.

PART NO.	CODE NO.	NUMBER OF CONTACTS	DIMENSION TABLE OF CONNECTOR, FPC, FFC, PCB MOUNTING PATTERN AND STENCIL PATTERN							DIMENSION TABLE OF DRAWING FOR PACKING 						
			A	B	C	D	E	F	G	H	J	K	L	M	N	P
FH12- 6S-0.5SVA(54)	CL586-0756-4-54	6	6.4	4.9	2.5	4.5	6.2	2	3.5	16	—	7.5	6.5	17.4	21.4	2
FH12-10S-0.5SVA(54)	CL586-0806-0-54	10	8.4	6.9	4.5	6.5	8.2	4	5.5	16	—	7.5	8.5	17.4	21.4	3
FH12-12S-0.5SVA(54)	CL586-0757-7-54	12	9.4	7.9	5.5	7.5	9.2	4	6.5	16	—	7.5	9.5	17.4	21.4	4
FH12-13S-0.5SVA(54)	CL586-0807-3-54	13	9.9	8.4	6	8	9.7	4	7	24	—	11.5	10	25.4	29.4	4
FH12-15S-0.5SVA(54)	CL586-0808-6-54	15	10.9	9.4	7	9	10.7	4	8	24	—	11.5	11	25.4	29.4	4
FH12-16S-0.5SVA(54)	CL586-0809-9-54	16	11.4	9.9	7.5	9.5	11.2	4	8.5	24	—	11.5	11.5	25.4	29.4	4
FH12-17S-0.5SVA(54)	CL586-0810-8-54	17	11.9	10.4	8	10	11.7	4	9	24	—	11.5	12	25.4	29.4	4
FH12-18S-0.5SVA(54)	CL586-0811-0-54	18	12.4	10.9	8.5	10.5	12.2	4	9.5	24	—	11.5	12.5	25.4	29.4	4
FH12-20S-0.5SVA(54)	CL586-0812-3-54	20	13.4	11.9	9.5	11.5	13.2	4	10.5	24	—	11.5	13.5	25.4	29.4	4
FH12-22S-0.5SVA(54)	CL586-0813-6-54	22	14.4	12.9	10.5	12.5	14.2	8	11.5	24	—	11.5	14.5	25.4	29.4	6
FH12-24S-0.5SVA(54)	CL586-0814-9-54	24	15.4	13.9	11.5	13.5	15.2	8	12.5	24	—	11.5	15.5	25.4	29.4	6
FH12-26S-0.5SVA(54)	CL586-0815-1-54	26	16.4	14.9	12.5	14.5	16.2	8	13.5	24	—	11.5	16.5	25.4	29.4	6
FH12-30S-0.5SVA(54)	CL586-0750-8-54	30	18.4	16.9	14.5	16.5	18.2	8	15.5	32	28.4	14.2	18.5	33.4	37.4	6
FH12-32S-0.5SVA(54)	CL586-0816-4-54	32	19.4	17.9	15.5	17.5	19.2	8	16.5	32	28.4	14.2	19.5	33.4	37.4	6
FH12-33S-0.5SVA(54)	CL586-0818-0-54	33	19.9	18.4	16	18	19.7	8	17	32	28.4	14.2	20	33.4	37.4	6
FH12-34S-0.5SVA(54)	CL586-0817-7-54	34	20.4	18.9	16.5	18.5	20.2	8	17.5	44	40.4	20.2	20.5	45.4	49.4	6
FH12-36S-0.5SVA(54)	CL586-0819-2-54	36	21.4	19.9	17.5	19.5	21.2	8	18.5	44	40.4	20.2	21.5	45.4	49.4	6
FH12-40S-0.5SVA(54)	CL586-0804-5-54	40	23.4	21.9	19.5	21.5	23.2	8	20.5	44	40.4	20.2	23.5	45.4	49.4	6
FH12-45S-0.5SVA(54)	CL586-0820-1-54	45	25.9	24.4	22	24	25.7	8	23	44	40.4	20.2	26	45.4	49.4	6
FH12-49S-0.5SVA(54)	CL586-0821-4-54	49	27.9	26.4	24	26	27.7	8	25	44	40.4	20.2	28	45.4	49.4	6
FH12-50S-0.5SVA(54)	CL586-0805-8-54	50	28.4	26.9	24.5	26.5	28.2	8	25.5	44	40.4	20.2	28.5	45.4	49.4	6
FH12-60S-0.5SVA(54)	CL586-0749-9-54	60	33.4	31.9	29.5	31.5	33.2	8	30.5	56	52.4	26.2	33.5	57.4	61.4	6

HRS DRAWING FOR REFERENCE

HRS	DRAWING NO.	EDC3-159266-03	
	PART NO.	FH12-**S-0.5SVA(54)	
	CODE NO.	CL586	 5/9

Jan.1.2025 Copyright 2025 HIROSE ELECTRIC CO., LTD. All Rights Reserved.
 In case of consideration for using Automotive equipment / device which demand high reliability, kindly contact our sales window correspondents.

This connector requires delicate and careful handling.
 To prevent connector/FPC breakage and contact failure (mating failure, FPC pattern breakage, etc),
 read through the instructions shown below and handle the connector properly.
 This instruction manual is applicable to usage with FPC/FFC.

[Connector part nomenclature]

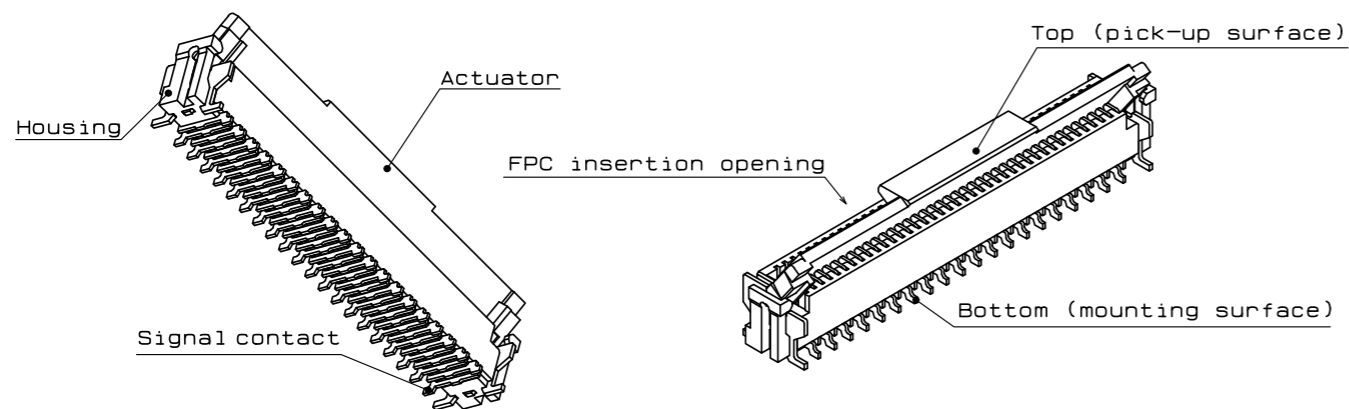

[Operation and precautions]

1. Initial condition
 The product is supplied with the actuator opened (actuator is standing vertically state). (Example 1)
 Actuator does not have to be operated before inserting FPC.

[Caution]

- Do not close the actuator when the FPC is not inserted (Example 2).
- Do not insert FPC or operate actuator before mounting (Example 2).

Example 1)
 - When delivered -

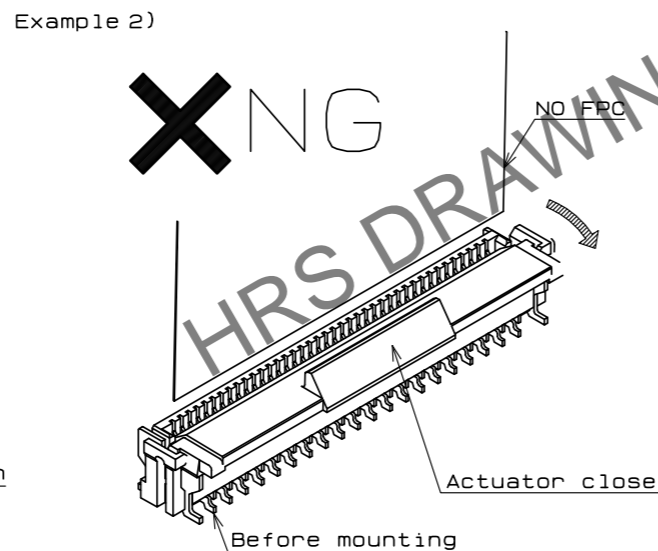
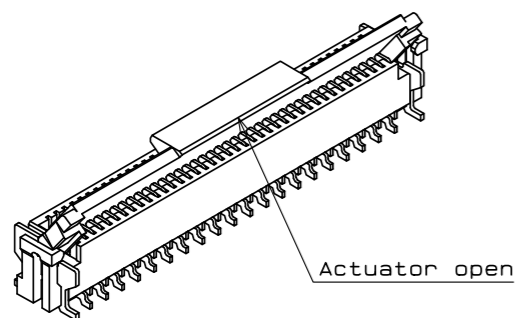

2. How to insert FPC
 Insert the FPC into the connector opening vertically to the PCB surface (Example 3).
 Insert it properly to the very end.

[Caution]

- Make sure the actuator is closed when inserting the FPC.
 Do not insert the FPC when the actuator is close (Example 4).
 While actuator is close, it is structured so that FPC can't be inserted,
 but if it is forced to insert FPC it will cause breakage.
- Do not insert the FPC when the actuator is pressed from above a finger (Example 5).
- Insert the FPC pattern surface on the opposite side of the actuator operation part (Example 6).
- Align both sides of the tip of FPC vertically to the sides of the connector opening and insert straight forward (Example 7).
- Do not twist the FPC to up and down or right and left or an angle (Example 8, 9).
- Do not close actuator with fingers when insert FPC (Example 10).

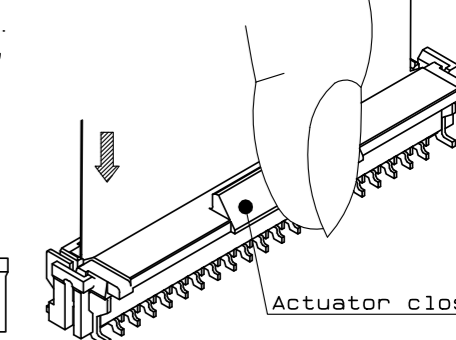
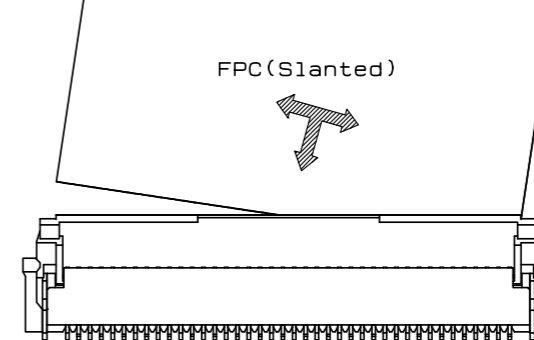
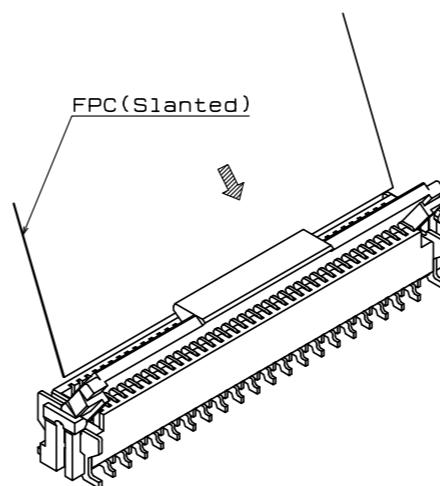
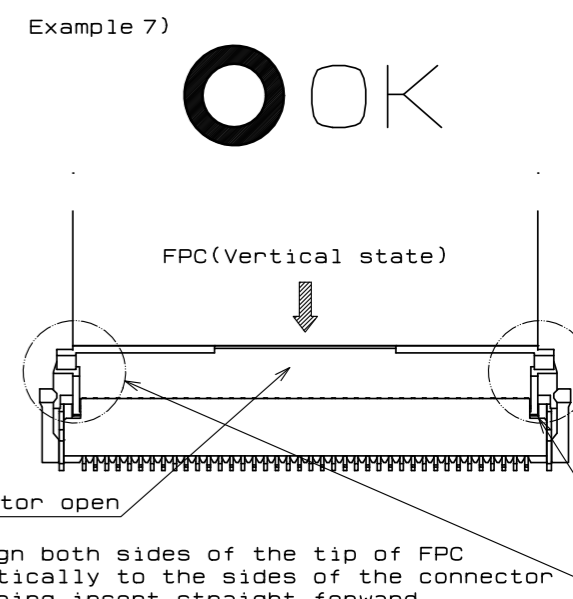
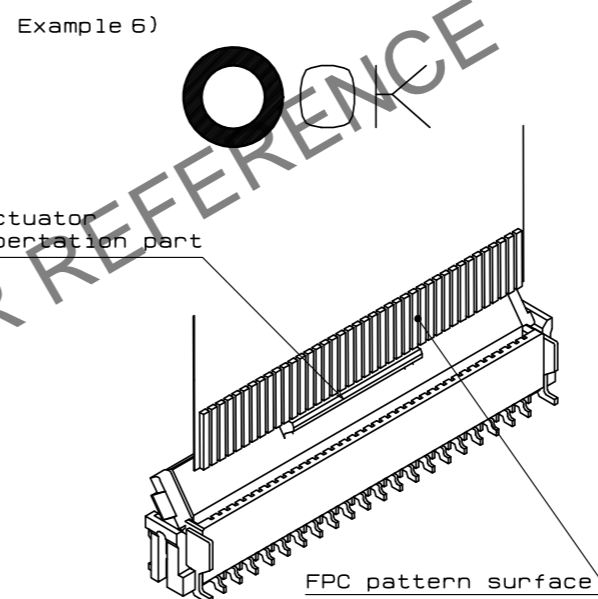
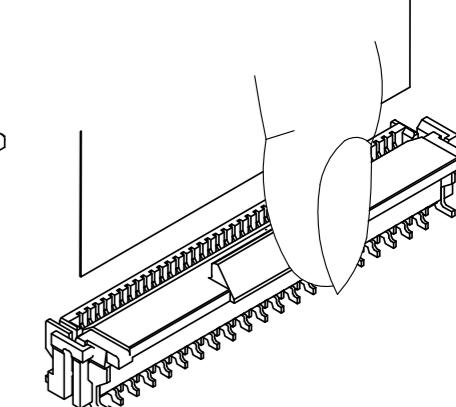
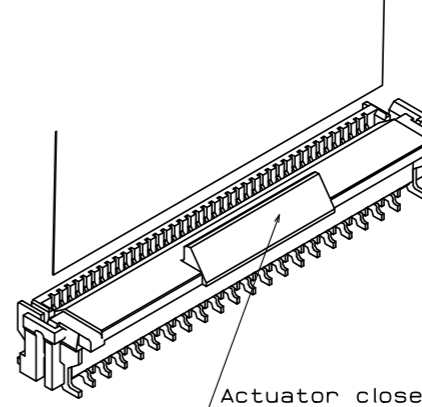
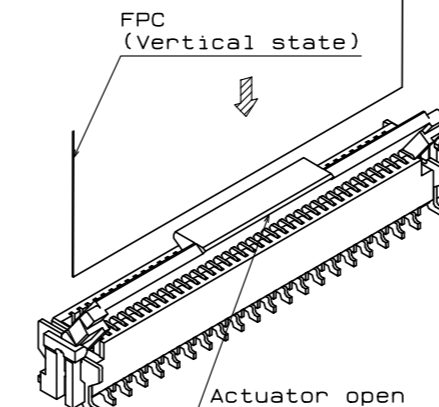
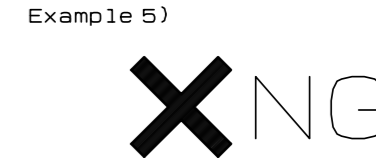

<Instruction manual(1)> ▲

HRS	DRAWING NO.	EDC3-159266-03
	PART NO.	FH12-**S-0.5SVA(54)
	CODE NO.	ClCode
		▲ 6/9

Jan.1.2025 Copyright 2025 HIROSE ELECTRIC CO., LTD. All Rights Reserved.
In case of consideration for using Automotive equipment / device which demand high reliability, kindly contact our sales window correspondents.

3. FPC insertion check
 Make sure that the FPC tabs are located in proper position after FPC insertion (Example 11).
 (The FPC position is to be aligned by the protrusion of the housing.)

[Caution]
 - Do not insert the FPC at an angle and/or stop it before insertion is completed (Example 12).

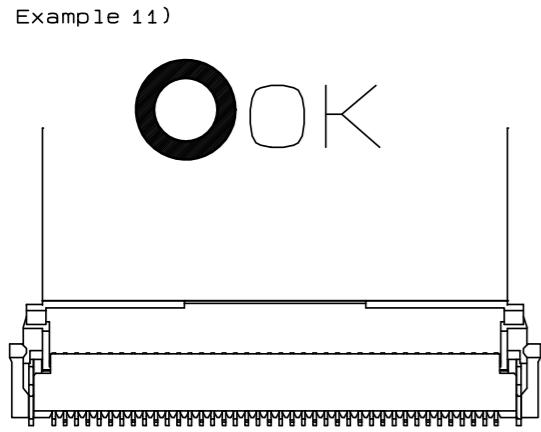

FPC is completely inserted to the end.

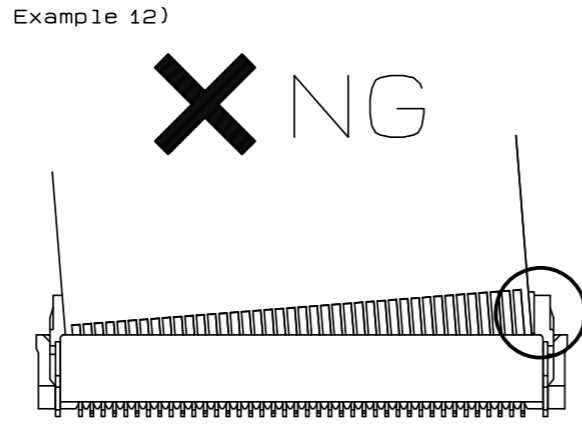

FPC is inserted in slanted angle and not fully inserted to the end.

4. Use of the actuator(open/close)
 Slowly flip down the actuator to the lock (Example 13).
 Slowly flip up the actuator to release the lock (Example 14).

[Caution]
 - To open/close the actuator, operate at the center of the actuator (Example 15).
 - To open/close the actuator, do not operate the actuator at one end only (Example 16).
 - The actuator is closed up to the movable limit, 90 degree. Do not close the actuator beyond the specified degree or apply excess force to the actuator(Example 17).
 - Do not pick the actuator to lift and pull it (Example 18).
 - Operate the actuator by hand without using sharp tool such as Tweezers. (Example 19).
 - Do not apply excess force to the actuator during the operation (Example 20).

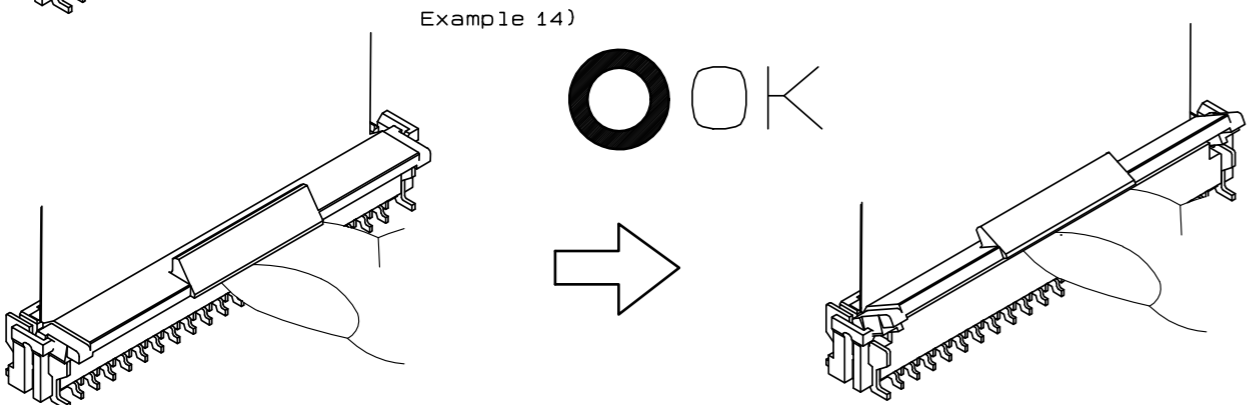
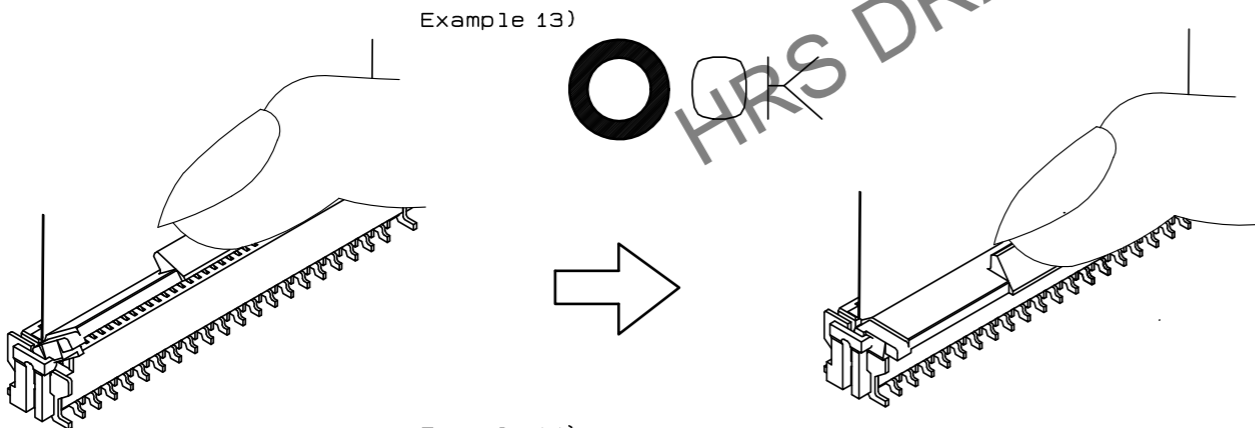

Example 15)



Operate the actuator at the center.

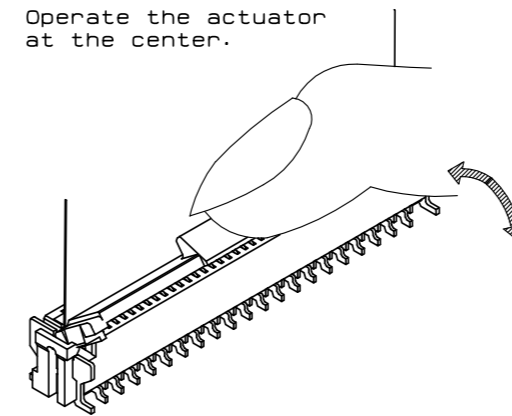

Example 16)



Do not operate the actuator at one end only

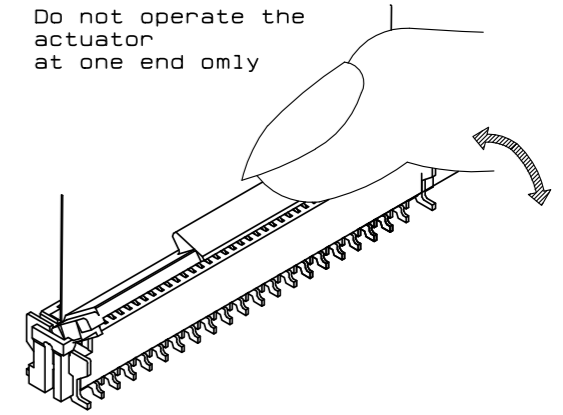

Example 17)

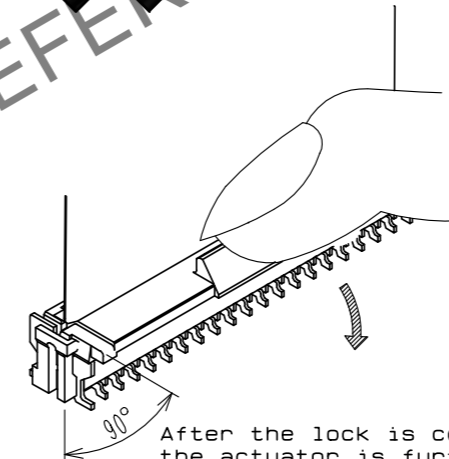

Example 18)

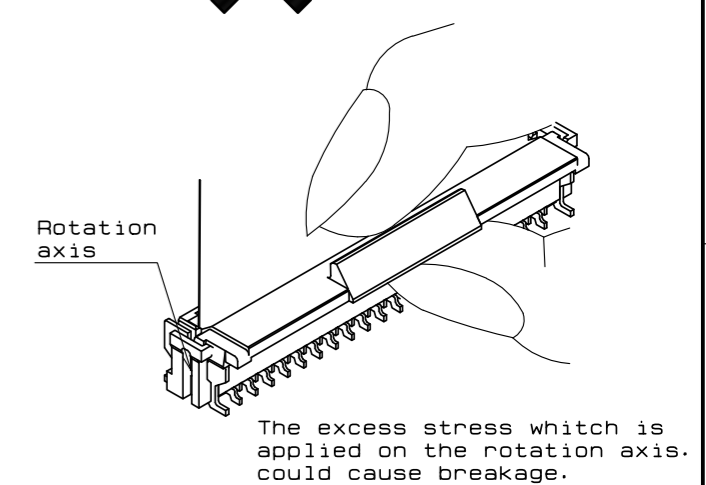

Example 19)

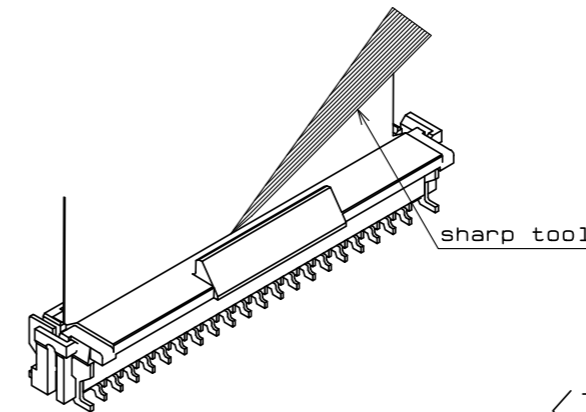

Example 20)

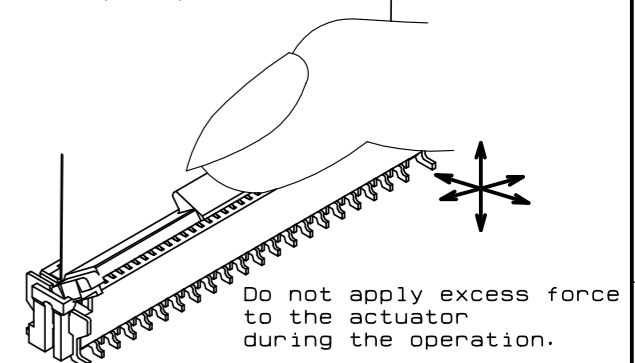

<Instruction manual(2)>

HRS	DRAWING NO.	EDC3-159266-03	
	PART NO.	FH12-**S-0.5SVA(54)	
	CODE NO.	ClCode	

Jan.1.2025 Copyright 2025 HIROSE ELECTRIC CO., LTD. All Rights Reserved.
In case of consideration for using Automotive equipment / device which demand high reliability, kindly contact our sales window correspondents.

5. How to remove FPC
After flip up the actuator to the fully opened position vertically withdraw the FPC(Example 21).

- [Caution]
- Do not attempt to pull the FPC without unlocking the housing(Example 22).
 - After forcibly remove FPC, retention force of FPC may decrease.
 - This connector has a temporary FPC holding structure with the housing. For FPC removal, do not pull out the FPC other than in the vertically direction of the PCB(Example 23).

[Precautions for component layout]

Depending on a FPC rounding, a load is applied to the connector, and a contact failure may occur. To prevent a failure, take the following notes into a consideration during mechanism design.

- [Caution]
- When fixing FPC after FPC cabling, avoid pulling FPC, and route the wire FPC with slack. In this regard, the stiffener is vertical to the PCB(Example24).
 - Avoid applying forces to FPC in vertical or horizontal directions. Do not bend the FPC excessively near the connector during use, or it may cause contact failure or FPC breakage. Stabilizing the FPC is recommended(Example 25, 26).
 - Do not mount other components or enclosure touching to the FPC underneath the FPC stiffener(Example27).
 - Make adjustments with the FPC manufacturer for FPC bending performance and wire breakage.
 - Keep a sufficient FPC insertion space in the stage of the layout in order to avoid incorrect FPC insertion. Appropriate FPC length and component layout are recommended for assembly ease. Too short FPC length makes assembly difficult.
 - Keep spaces for the locking lever movement and its operation for PCB design and component layout.
 - Please consult with our sales representative you are using FPC/FFC with different configuration from our recommendation.

Example 21)

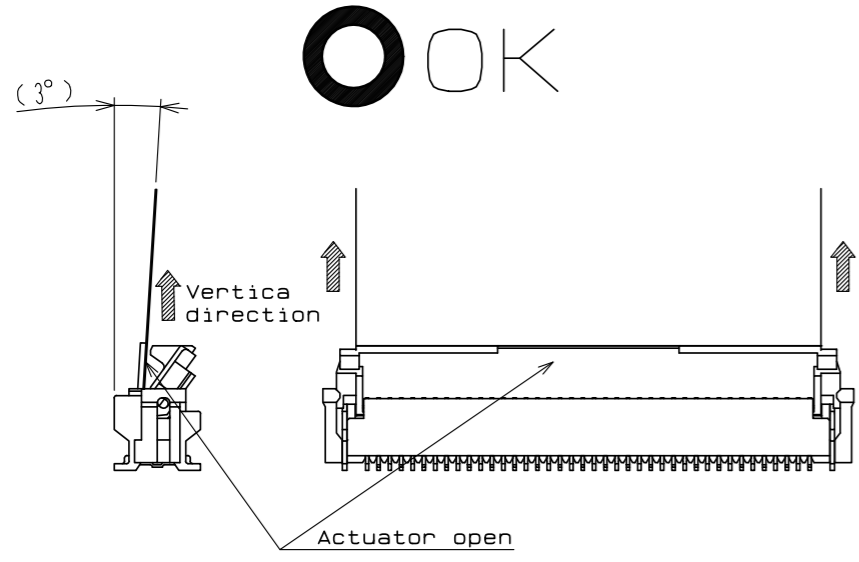

Example 22)

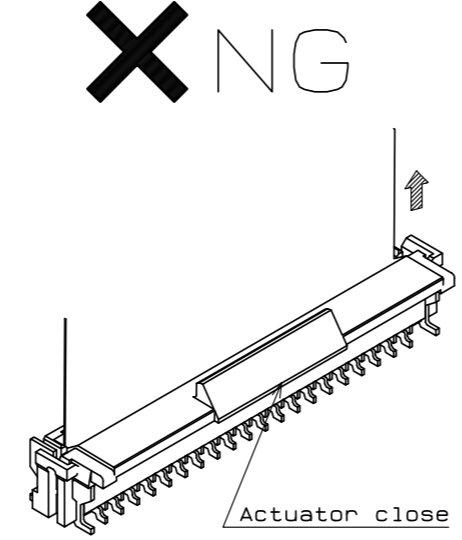

Example 24)

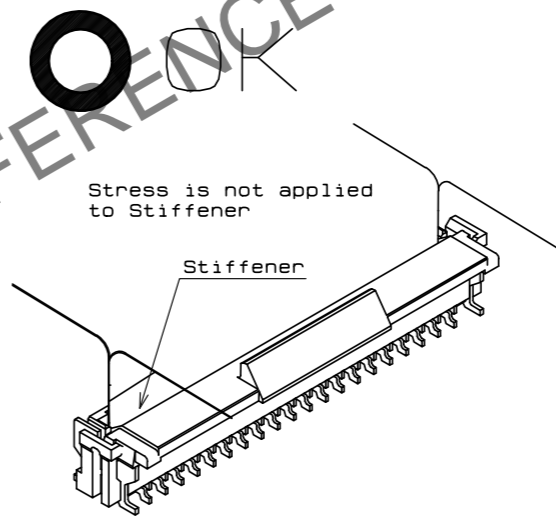

Example 25)

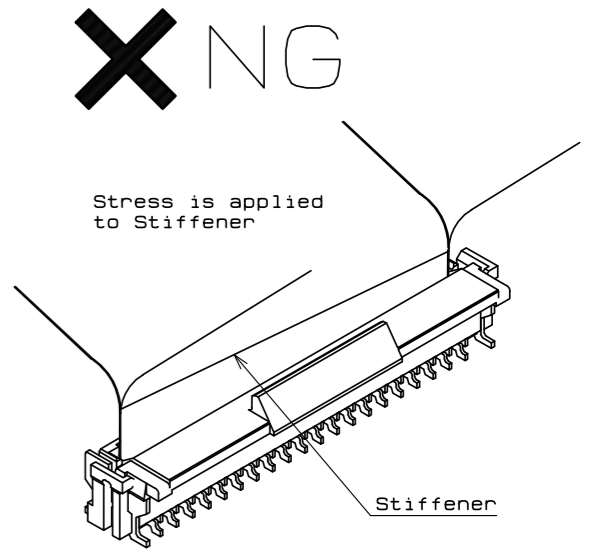

Example 23)

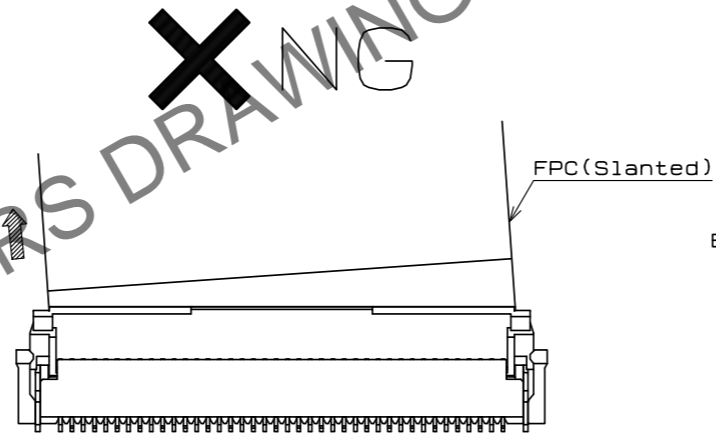
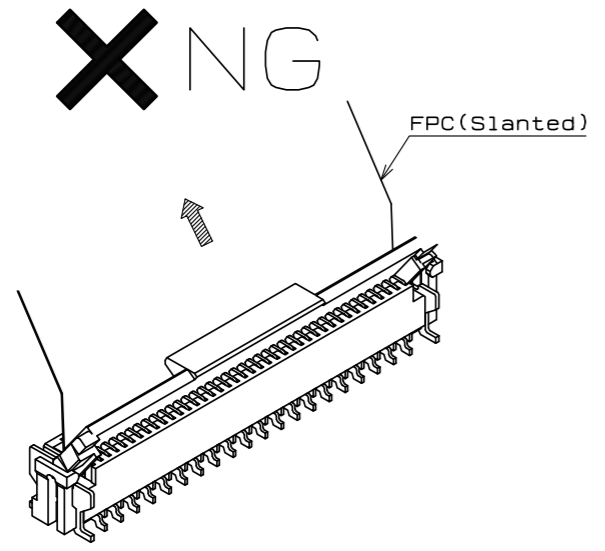

Example 26)

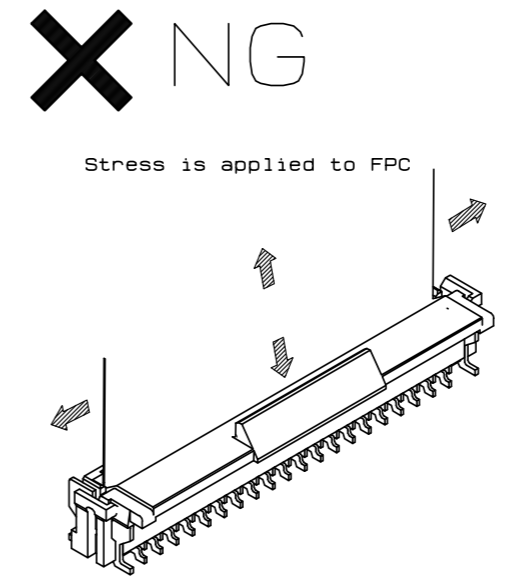

Example 27)

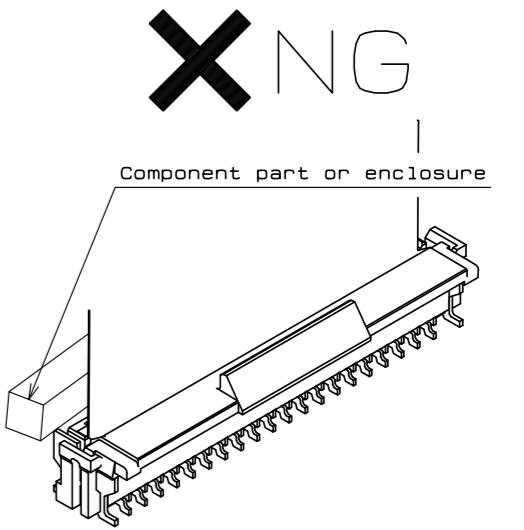

<Instruction manual(3)>

HRS	DRAWING NO.	EDC3-159266-03
	PART NO.	FH12-**S-0.5SVA(54)
	CODE NO.	ClCode
		8/9

Jan.1.2025 Copyright 2025 HIROSE ELECTRIC CO., LTD. All Rights Reserved.
In case of consideration for using Automotive equipment / device which demand high reliability, kindly contact our sales window correspondents.

[Instructions for mounting on the PCB]

Follow the instructions shown below when mounting on the PCB.

[Caution]

- Refer to recommended layouts on the page 1 for PCB and stencil pattern.
- Shorter pattern width than the recommended PCB dimension, could cause solder wicking and/or flux penetration.
- Larger pattern than the recommended stencil dimension, could cause solder wicking and/or flux penetration.
- Clearance underneath the contact lead and the housing is very small. In case solder resist and/or silk screening are applied on PCB underneath the connector, verify the thickness, or it could push up the connector bottom and may cause soldering defect and/or insufficient fillet formation.
- Apply reflow temperature profile within the specified conditions. In individual applications, the actual temperature may vary, depending on solder paste type, volume/thickness and PCB size/thickness. Consult your solder paste and equipment manufacturer for specific recommendations.
- Prevent warpage of PCB, where possible, since it can cause soldering failure even with 0.1 mm max coplanarity.
- When mounting on the flexible board, please make sure to put a stiffener on the backside of the flexible board. We recommend a glass epoxy material with the thickness of 0.3 mm min.
- Do not add 1.0 N or greater external force when unreel or pick and place the connector etc, or it may get broken.

[Instructions for PCB handling after mounting the connector]

Follow the instructions shown below when mounting on the PCB.

[Caution]

- Splitting a large PCB into several pieces
 - Screwing the PCB
- During the handling described above, do not exert an excessive force on the PCB. Otherwise, the connector may become defective.
- The warp of a 100 mm wide PCB should be 1.0 mm or less. The warp of PCB suffers stress on connector and the connector may become defective (Example 27).

Example 27)

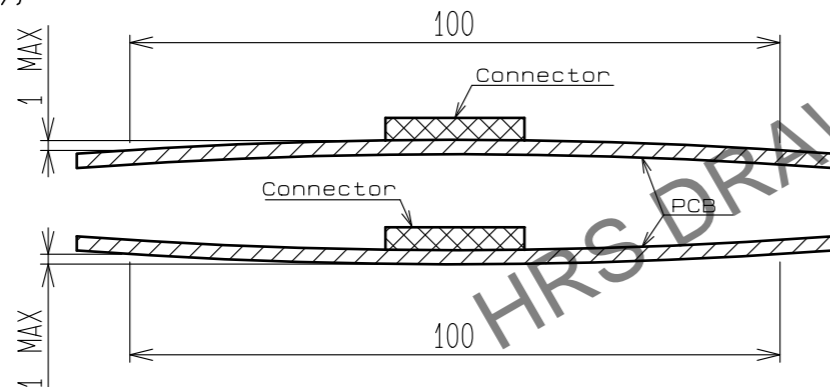

[Recommended reflow temperature profile]

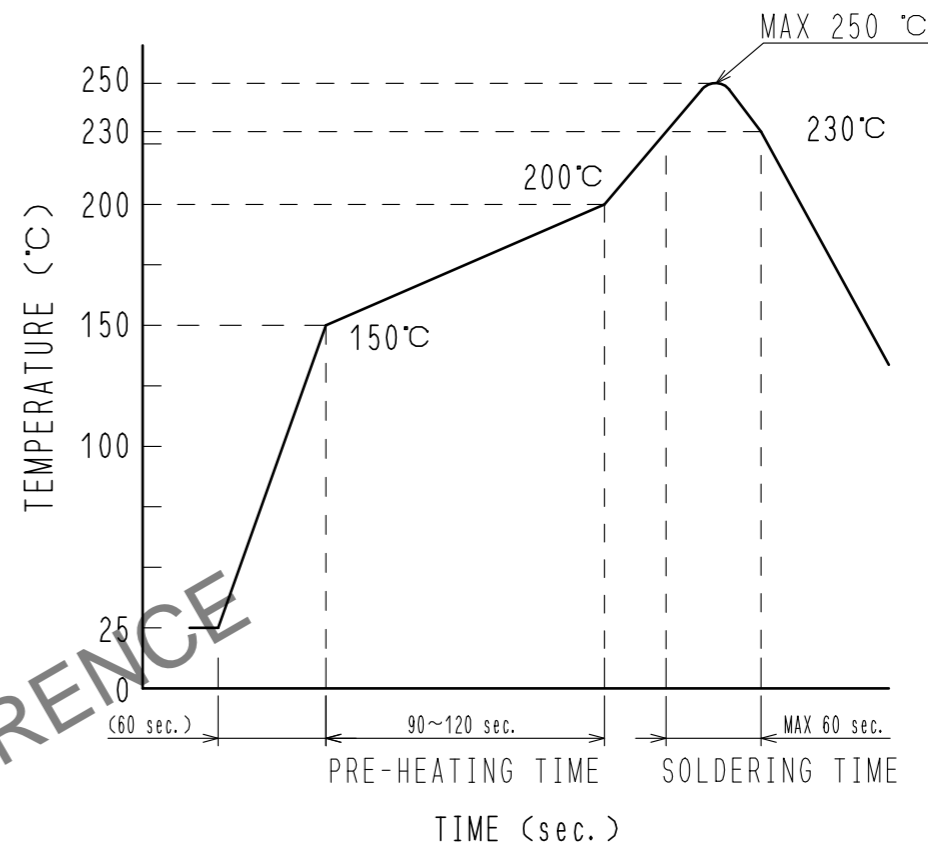

Reflow method: IR reflow
 Number of reflow cycles: 2 cycles MAX.
 1) Reflow time
 Duration above 230°C: 60 sec MAX.
 (Peak temperature: 250°C MAX)
 2) Pre-heat time
 Pre-heat temperature (MIN): 150°C
 Pre-heat temperature (MAX): 200°C
 Pre-heat time: 90~120 sec.

[Instructions on manual soldering]

Follow the instructions shown below when soldering the connector manually during repair work, etc.

[Caution]

- Do not perform manual soldering with the FPC inserted into the connector.
 - Do not heat the connector excessively. Be very careful not to let the soldering iron contact any parts other than connector leads. Otherwise, the connector may be deformed or melt.
 - Do not supply excessive solder (or flux).
- If excessive solder (or flux) is supplied on the terminals, solder or flux may adhere to the contacts, resulting in poor contact. Supplying excessive solder to the metal fittings may hinder locking lever rotation, resulting in breakage of the connector.

<Instruction manual(4)>

HRS	DRAWING NO.	EDC3-159266-03
	PART NO.	FH12-**S-0.5SVA(54)
	CODE NO.	ClCode 9/9