

Dec.1.2021 Copyright 2021 HIROSE ELECTRIC CO., LTD. All Rights Reserved.
 In case of consideration for using Automotive equipment / device which demand high reliability, kindly contact our sales window correspondents.

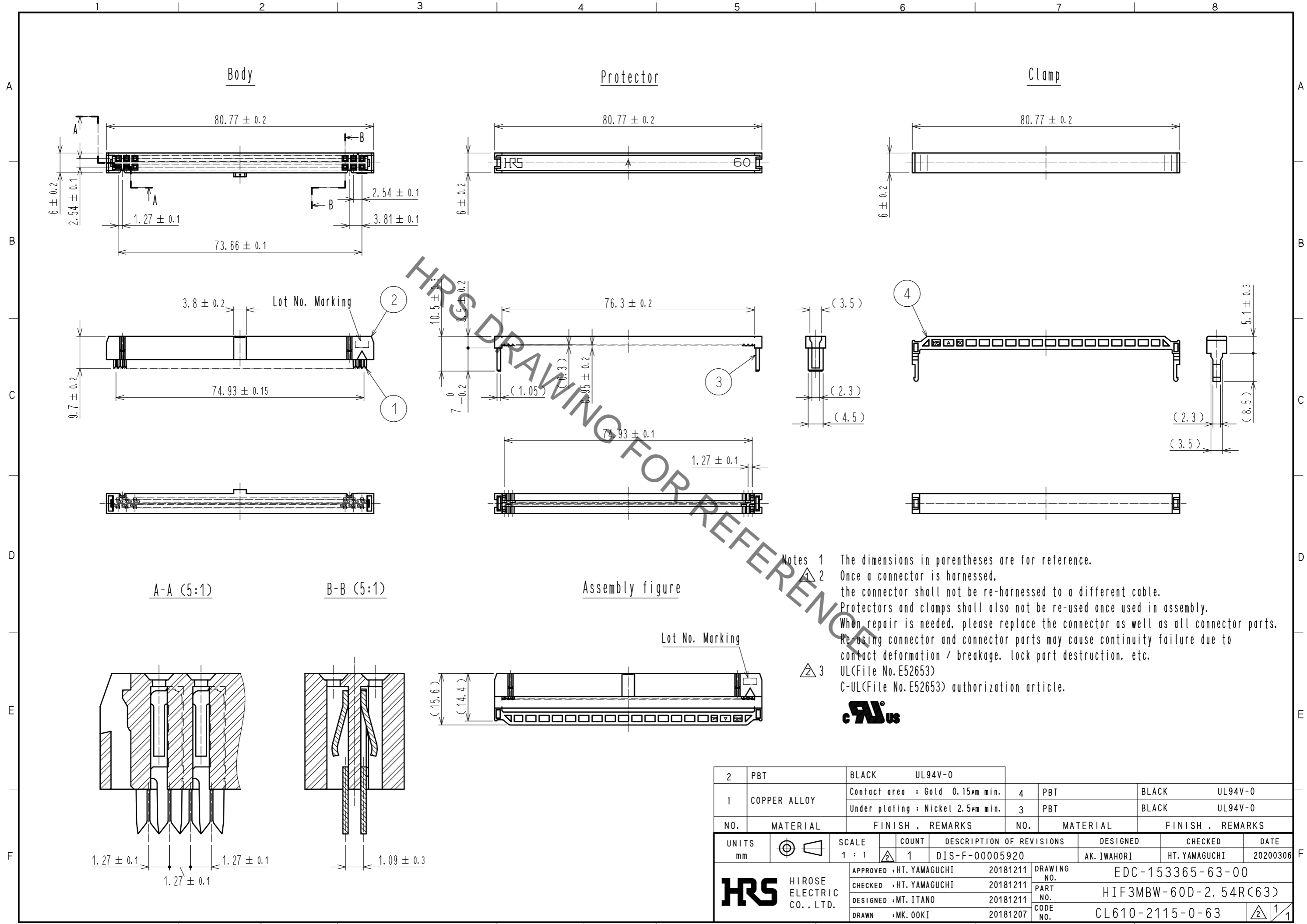

Notes 1 The dimensions in parentheses are for reference.
 2 Once a connector is harnessed, the connector shall not be re-harnessed to a different cable. Protectors and clamps shall also not be re-used once used in assembly. When repair is needed, please replace the connector as well as all connector parts. Re-using connector and connector parts may cause continuity failure due to contact deformation / breakage, lock part destruction, etc.
 3 UL(File No. E52653)
 C-UL(File No. E52653) authorization article.

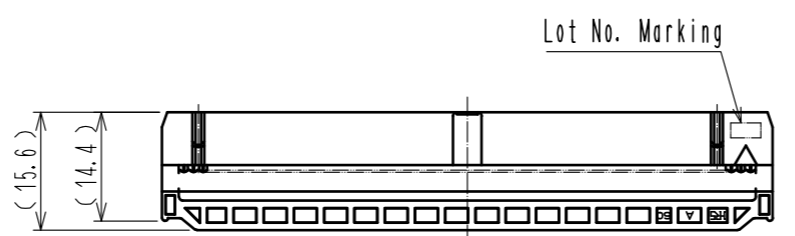
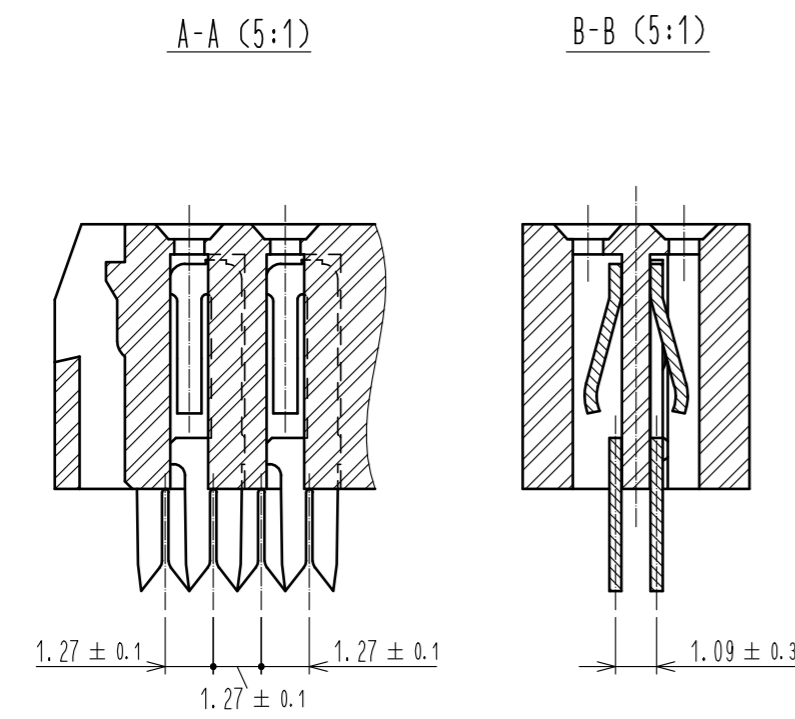

2	PBT	BLACK	UL94V-0						
1	COPPER ALLOY	Contact area : Gold	0.15µm min.	4	PBT	BLACK	UL94V-0		
		Under plating : Nickel	2.5µm min.	3	PBT	BLACK	UL94V-0		
NO.	MATERIAL	FINISH	REMARKS	NO.	MATERIAL	FINISH	REMARKS		
UNITS	mm	SCALE	1 : 1	COUNT	1	DESCRIPTION OF REVISIONS	DESIGNED	CHECKED	DATE
						DIS-F-00005920	AK. IWAHORI	HT. YAMAGUCHI	20200306
APPROVED : HT. YAMAGUCHI				20181211		DRAWING NO. EDC-153365-63-00			
CHECKED : HT. YAMAGUCHI				20181211		PART NO. HIF3MBW-60D-2.54R(63)			
DESIGNED : MT. ITANO				20181211		CODE NO. CL610-2115-0-63			
DRAWN : MK. OKI				20181207					