

Jul.1.2024 Copyright 2024 HIROSE ELECTRIC CO., LTD. All Rights Reserved.
 In case of consideration for using Automotive equipment / device which demand high reliability, kindly contact our sales window correspondents.

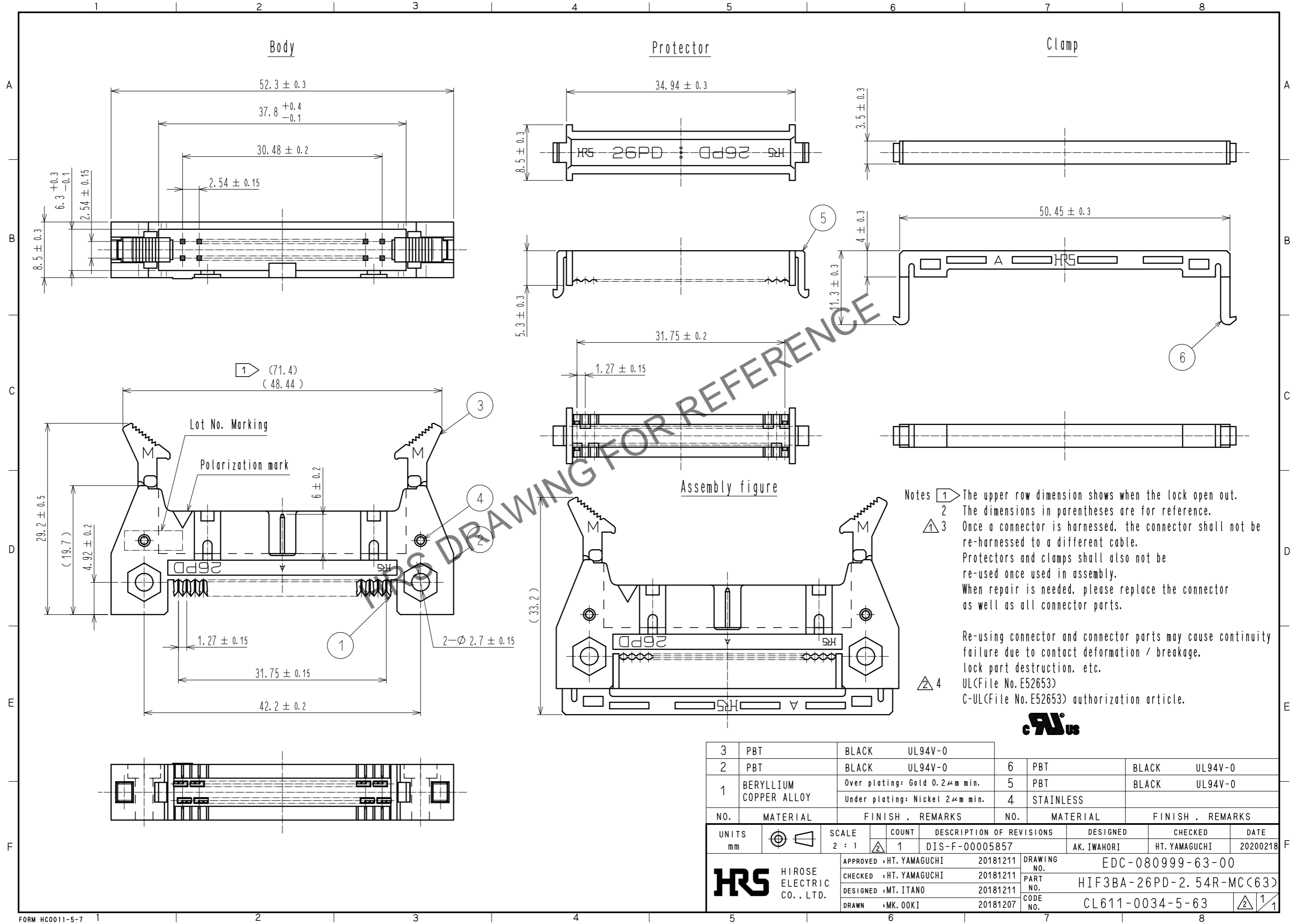

Notes

- 1 The upper row dimension shows when the lock open out.
- 2 The dimensions in parentheses are for reference.
- 3 Once a connector is harnessed, the connector shall not be re-harnessed to a different cable. Protectors and clamps shall also not be re-used once used in assembly. When repair is needed, please replace the connector as well as all connector parts.
- 4 Re-using connector and connector parts may cause continuity failure due to contact deformation / breakage, lock part destruction, etc.

UL(File No. E52653)
 C-UL(File No. E52653) authorization article.



3	PBT	BLACK	UL94V-0	6	PBT	BLACK	UL94V-0		
2	PBT	BLACK	UL94V-0	5	PBT	BLACK	UL94V-0		
1	BERYLLIUM COPPER ALLOY	Over plating: Gold 0.2µm min. Under plating: Nickel 2µm min.		4	STAINLESS				
NO.	MATERIAL	FINISH	REMARKS	NO.	MATERIAL	FINISH	REMARKS		
UNITS	mm	SCALE	2 : 1	COUNT	1	DESCRIPTION OF REVISIONS	DESIGNED	CHECKED	DATE
APPROVED : HT. YAMAGUCHI 20181211				DRAWING NO.		EDC-080999-63-00			
CHECKED : HT. YAMAGUCHI 20181211				PART NO.		HIF3BA-26PD-2.54R-MC(63)			
DESIGNED : MT. ITANO 20181211				CODE NO.		CL611-0034-5-63			
DRAWN : MK. OOKI 20181207									