

Jul.1.2024 Copyright 2024 HIROSE ELECTRIC CO., LTD. All Rights Reserved.  
 In case of consideration for using Automotive equipment / device which demand high reliability, kindly contact our sales window correspondents.

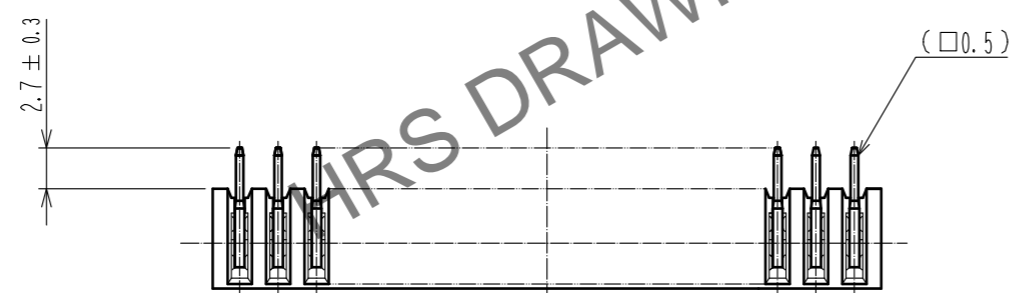

1 Lot No. Marking

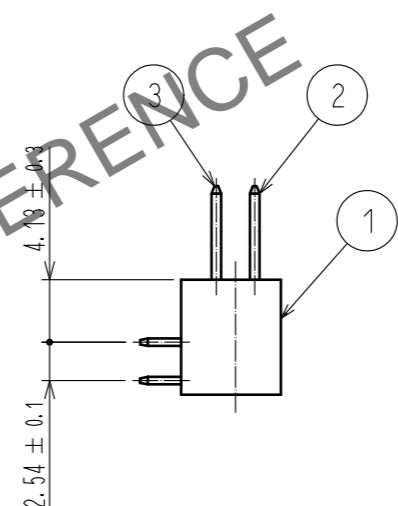
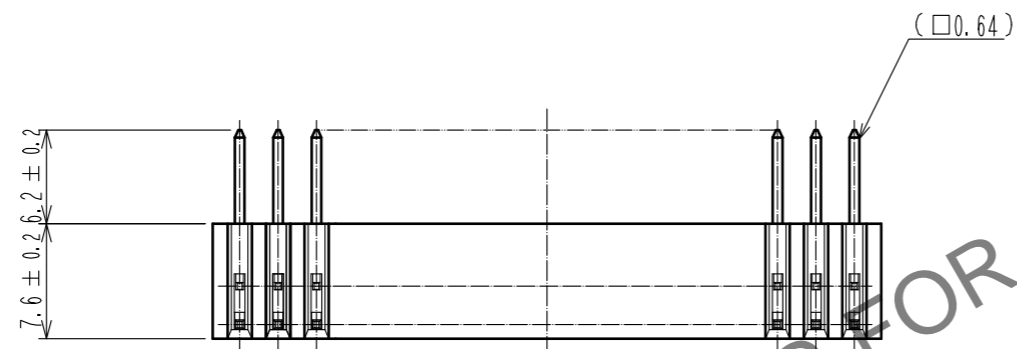
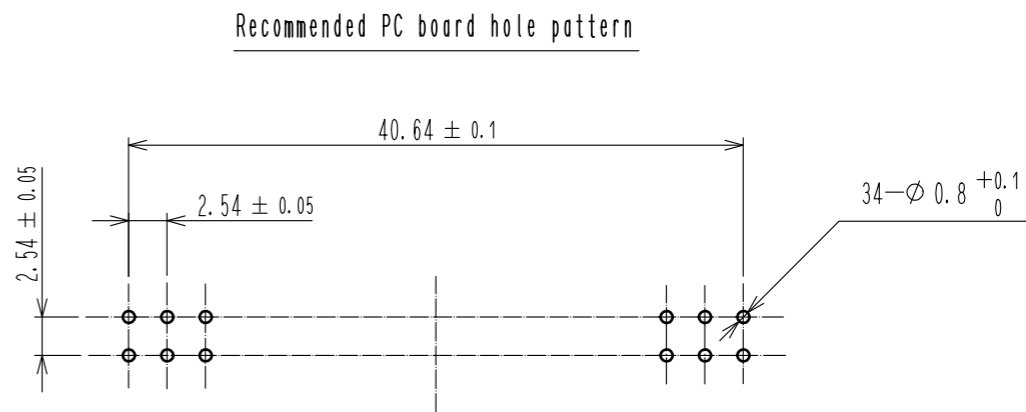
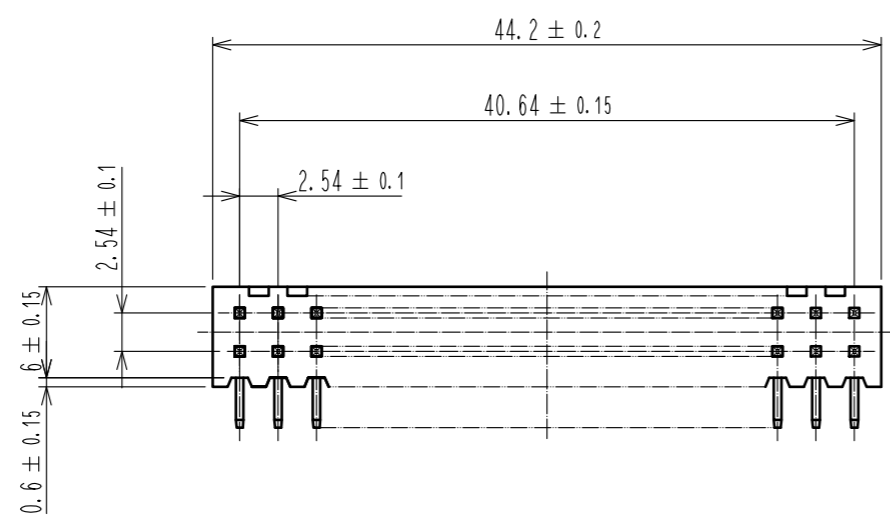

- Notes
- 1 The position of Lot No. is optional.
  - 2 The dimensions in parentheses are for reference.

3	BRASS	Contact area : Gold 0.2μm min. Dip area : TIN-Plating 2μm min. Under plating : Nickel 2.5μm min.
2	BRASS	Contact area : Gold 0.2μm min. Dip area : TIN-Plating 2μm min. Under plating : Nickel 2.5μm min.

NO.	MATERIAL	FINISH . REMARKS	NO.	MATERIAL	FINISH . REMARKS
1	PBT	BLACK UL94V-0			

UNITS	SCALE	COUNT	DESCRIPTION OF REVISIONS	DESIGNED	CHECKED	DATE
mm	2 : 1	△				

<b>HRS</b> HIROSE ELECTRIC CO., LTD.	APPROVED : HT. YAMAGUCHI	18.06.25	DRAWING NO.	EDC-016902-71-21
	CHECKED : HT. YAMAGUCHI	18.06.25	PART NO.	HIF3E-34PA-2.54DS(71)
	DESIGNED : MT. ITANO	18.06.25	CODE NO.	CL614-0046-3-71
	DRAWN : MK. OOKI	18.06.21		