

Dec.1.2024 Copyright 2024 HIROSE ELECTRIC CO., LTD. All Rights Reserved.  
In case of consideration for using Automotive equipment / device which demand high reliability, kindly contact our sales window correspondents.

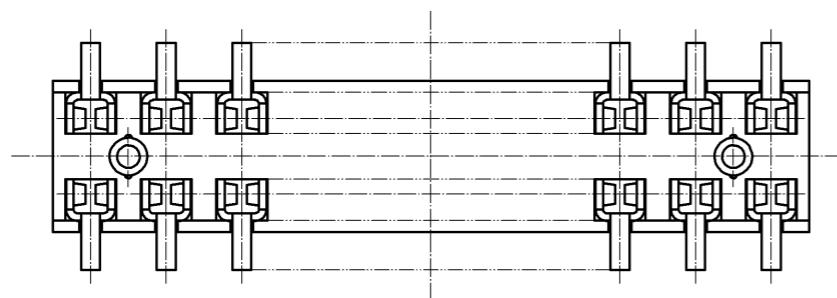

RECOMMENDED LAND PATTERN DIMENSION OF PCB (MOUNTING SIDE)  
(RECOMMENDED METAL MASK THICKNESS: 0.2mm)

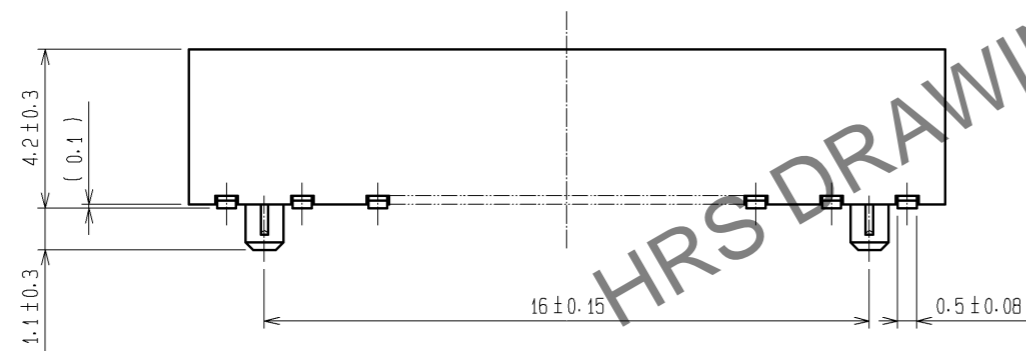
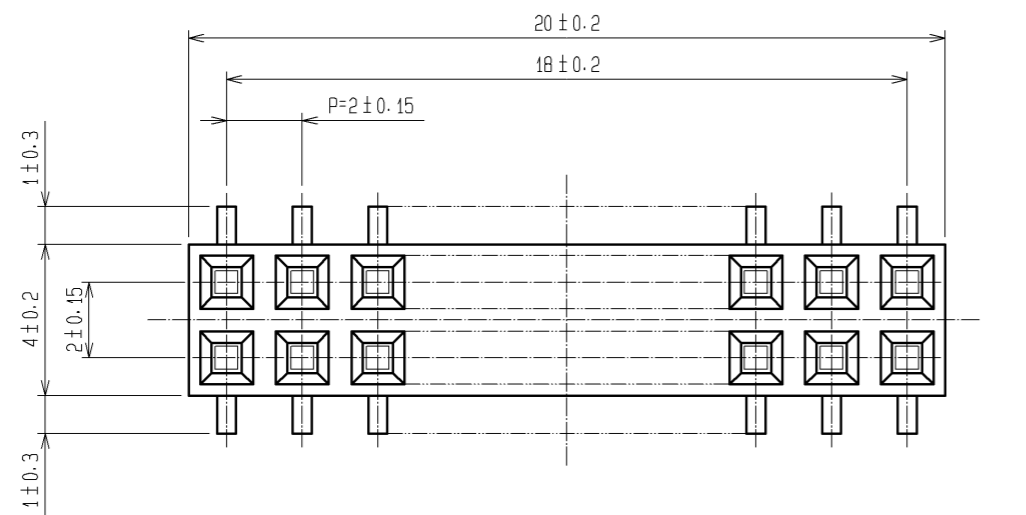
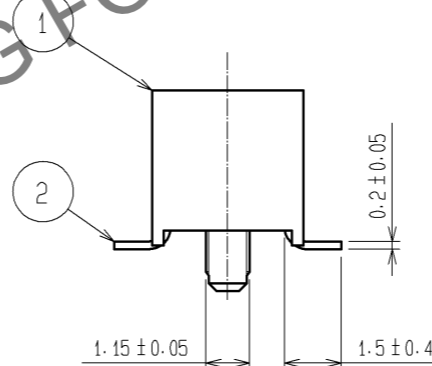
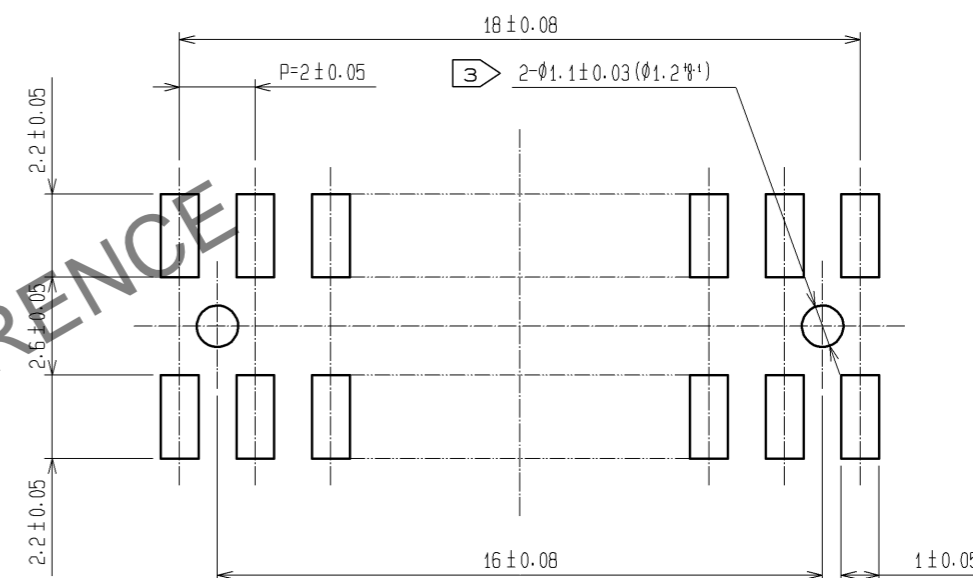

- NOTE 1 LEAD CO-PLANARITY SHALL BE 0.15 MAX.  
 2 THE DIMENSIONS IN PARENTHESES ARE FOR REFERENCE.  
 3 FOR AUTOMATED MOUNTING, RECOMMENDED THROUGH HOLE DIAMETER OF BOSS IS 1.2 ± 0.1.

1	PPS	LIGHT BROWN / UL94V-0	2	PHOSPHOR BRONZE	CONTACT AREA: GOLD 0.2μm min. LEAD AREA: TIN-PLATING 1μm min. UNDER PLATING: NICKEL 1μm min.		
NO.	MATERIAL	FINISH . REMARKS	NO.	MATERIAL	FINISH . REMARKS		
UNITS mm		SCALE 5 : 1	COUNT 	DESCRIPTION OF REVISIONS	DESIGNED	CHECKED	DATE
<b>HRS</b> HIROSE ELECTRIC CO., LTD.		APPROVED : HS. OKAWA	13. 02. 08	DRAWING NO.	EDC3-082680-21		
		CHECKED : HT. YAMAGUCHI	13. 02. 08	PART NO.	A3A-20DA-2SV(71)		
		DESIGNED : KJ. NISHIWAKI	13. 02. 08	CODE NO.	CL621-1148-7-71		
		DRAWN : CR. TAKESHIMA	13. 02. 08		1/1		