

Jan.1.2025 Copyright 2025 HIROSE ELECTRIC CO., LTD. All Rights Reserved.
 In case of consideration for using Automotive equipment / device which demand high reliability, kindly contact our sales window correspondents.

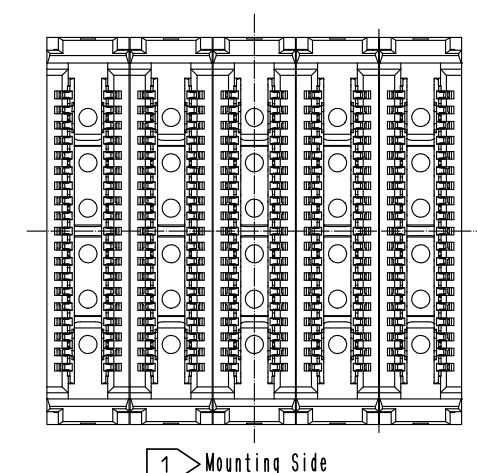
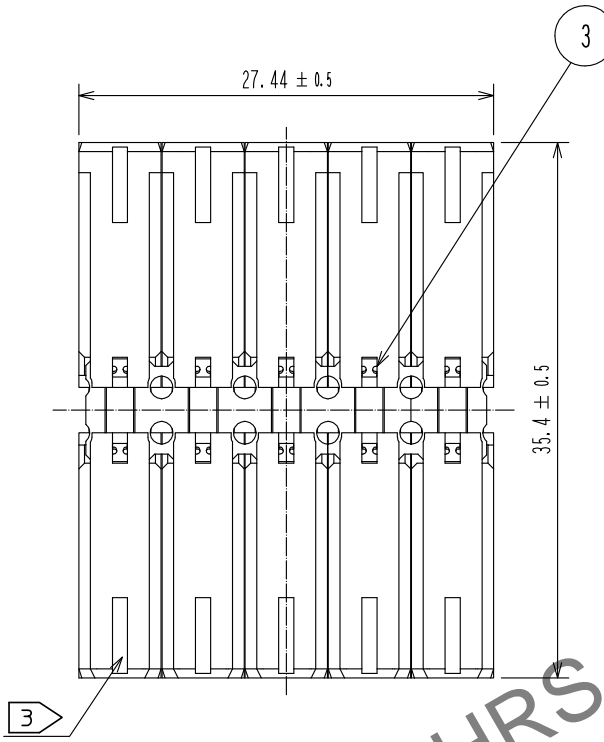
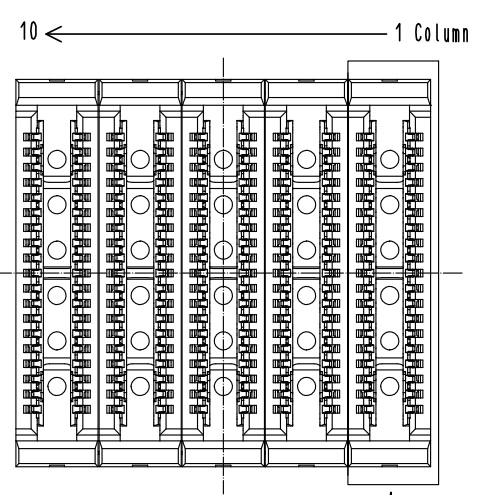

Note.

- 1 Mounting side is mated with Plug-M:IT8M-120P-BGA-H(**) and fixed with the latch.
- 2 Mating side is mated with Plug-D:IT8D-120P-BGA-H(**).
- 3 Lot No. shall be marked at the indicated position.
- 4 IT8 Series apply GSSG. pin assign as shown. Twisted pairs are indicated by the hatch marks. Twisted pairs are twisted in the center to reduce FEXT.
- 5 The indicated mother board and daughter card shall be fastened to the additional reinforcements to prevent the stress on IT8*-120P-BGA-H(**) solder joints.
- 6 This product consists of 120 signal contacts and 70 ground contacts.
- 7 The spacer height of this product assembled with mounted IT8M-120P-BGA-H(**) and IT8D-120P-BGA-H(**) shall be indicated in Table 1.

Table 1 Spacer height

| Spacer height (X) | 38 | 39 | 40 |
|--------------------------|----------------------|----------------------|----------------------|
| Plug-D (Detachable Side) | IT8D-***P-BGA-0H(**) | IT8D-***P-BGA-0H(**) | IT8D-***P-BGA-1H(**) |
| Interposer | IT8-***S-38H(**) | | |
| Plug-M (Mounting Side) | IT8M-***P-BGA-0H(**) | IT8M-***P-BGA-1H(**) | IT8M-***P-BGA-1H(**) |

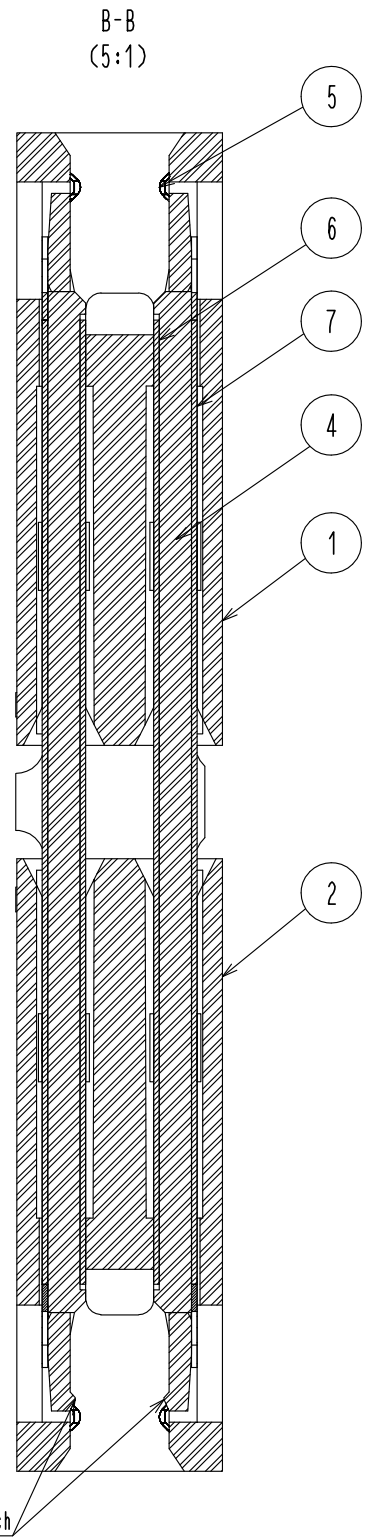
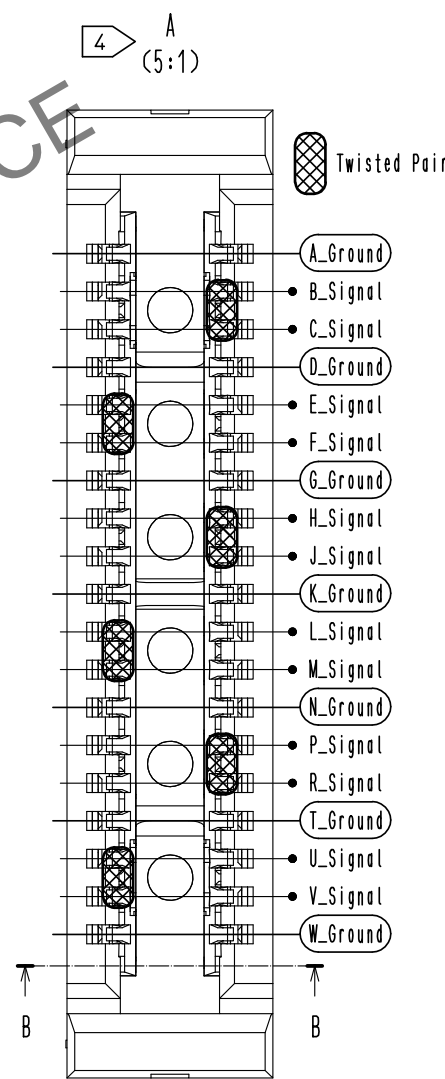
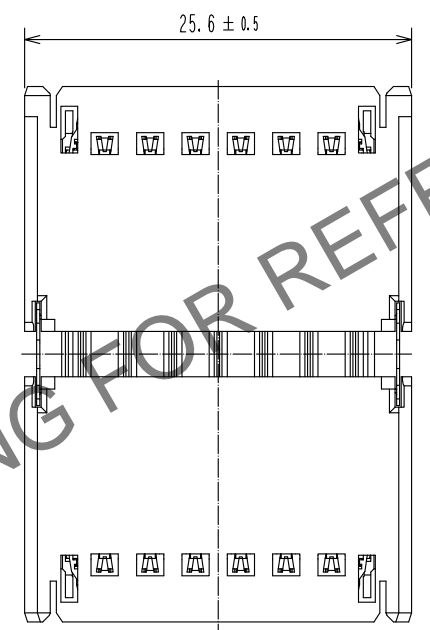

HRS DRAWING FOR REFERENCE

| 4 | LCP | BLACK, UL94V-0 | 7 | SUS | |
|-----|----------|------------------|-----|--------------|--|
| 3 | SUS | | 6 | SUS | |
| 2 | PPS | BLACK, UL94V-0 | 5 | Copper Alloy | Contact area:Nickel 1.27µm min.+Gold 0.76µm min. |
| 1 | PPS | GRAY, UL94V-0 | | | Other area:Nickel 1.27µm min. |
| NO. | MATERIAL | FINISH . REMARKS | NO. | MATERIAL | FINISH . REMARKS |

| UNITS | SCALE | COUNT | DESCRIPTION OF REVISIONS | DESIGNED | CHECKED | DATE |
|------------------------|-------|-------|--------------------------|------------------------------|---------|------|
| mm | 2 : 1 | △ | | | | |
| APPROVED : TM. MATSUO | | | 17.07.28 | DRAWING NO. EDC-372351-00-00 | | |
| CHECKED : YS. TAKEUCHI | | | 17.07.28 | PART NO. IT8-120S-38H | | |
| DESIGNED : TH. SANO | | | 17.07.26 | CODE NO. CL636-3517-0-00 | | |
| DRAWN : CHUNKAI YANG | | | 17.07.26 | 1/2 | | |

Jan.1.2025 Copyright 2025 HIROSE ELECTRIC CO., LTD. All Rights Reserved.
 In case of consideration for using Automotive equipment / device which demand high reliability, kindly contact our sales window correspondents.

IT8 Assembly Process

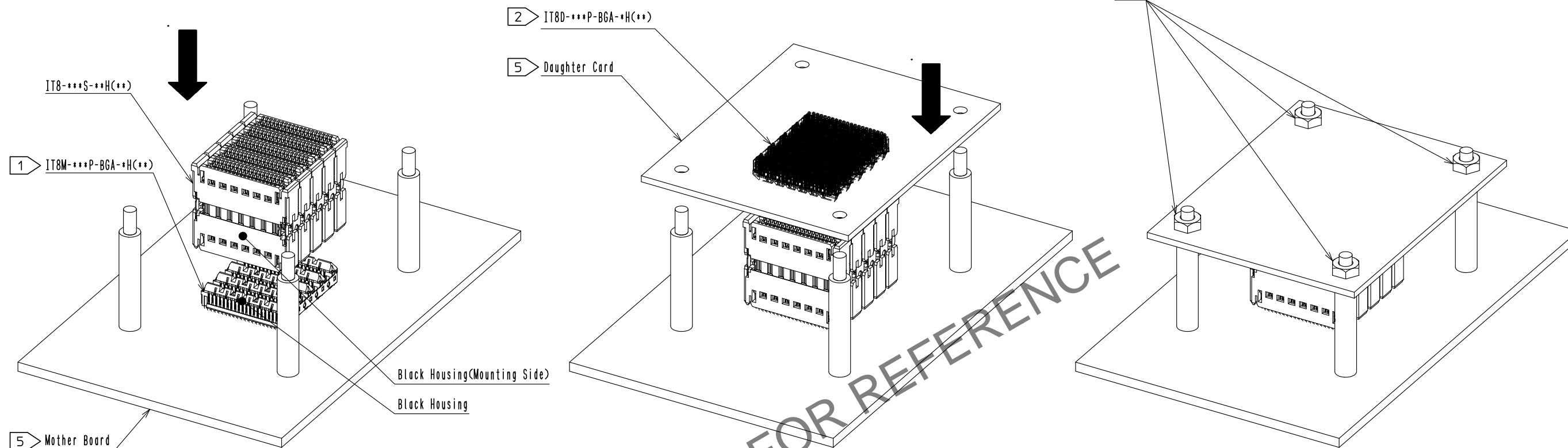

1) Insert mounting side of Interposer(IT8-***S-***H(**)) by pressing on top of Interposer into reflowed Mounting Plug(IT8M-***P-BGA-***H(**)) having black housings.

2) Insert Detachable Plug(IT8D-***P-BGA-***H(**)) having gray housings into mating side of Interposer(IT8-***S-***H(**)).

3) Install and tighten nuts to fix mated Detachable Plug after completion of mating.

IT8 Mated Condition

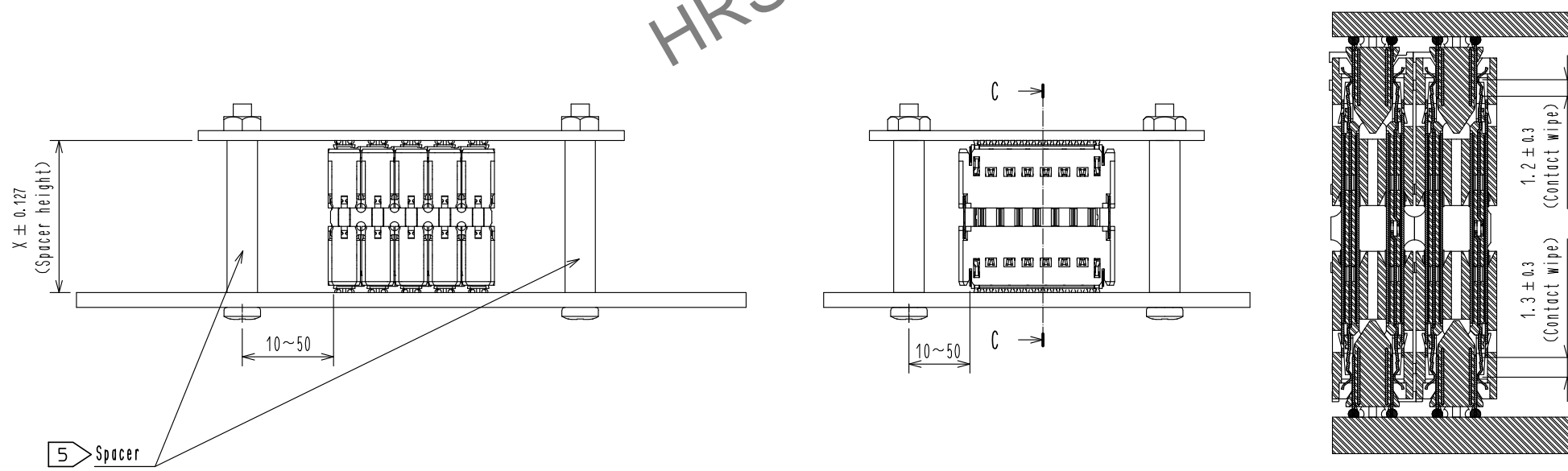

HRS DRAWING FOR REFERENCE

| | | |
|------------|-------------|------------------|
| HRS | DRAWING NO. | EDC-372351-00-00 |
| | PART NO. | IT8-120S-38H |
| | CODE NO. | CL636-3517-0-00 |
| | | 2/2 |