

**1.Coverage**

This document specifies mating/unmating operation for the DF56※-\*S-0.3V and DF56※-\*P-0.3SD(ASSY). (※: Classification, \*: Pin counts)

**2.Connector Product Name**

\*: Pin counts  
 ※: Classification

Part Number	Description	Composition
DF56※-*S-0.3V	Receptacle	DF56※-*S-0.3V (Connector body)
DF56※-*P-0.3SD(ASSY)	Plug	DF56※-*P-0.3SD + DF56※-*P-SHL (Plug body) (Metal shell)

**3.Operating Process**

3-1.Insertion

3-1-1: Align the center of the plug and the receptacle with referring to the edges of the plug and the receptacle, and place the plug on the receptacle right above.

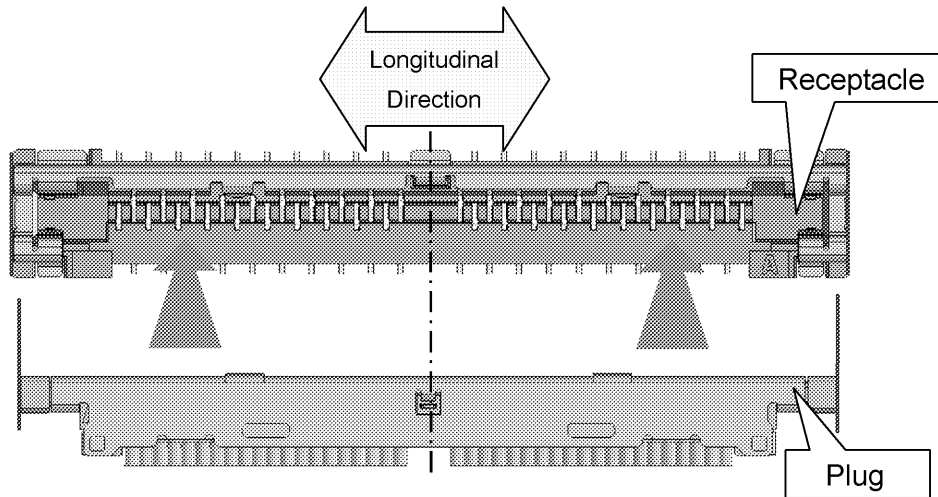

3-1-2: Slightly push the plug down to the receptacle and make sure that the plug is not shaky in depth and longitudinal directions, and then the plug is placed correctly at the center.

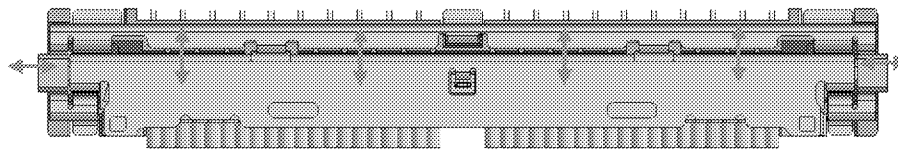

COUNT	DESCRIPTION OF REVISIONS	DESIGNED	CHECKED	DATE	
△ 1	DIS-D-002893	AH. MIYAZAKI	TS. SAKATA	13. 05. 21	
名称 TITLE		<b>HIROSE ELECTRIC CO., LTD.</b>			
DF56 Series Handling Guideline					
APPROVED	TS. SAKATA				10. 07. 22
CHECKED	HS. OZAWA				10. 07. 22
DESIGNED	AH. MIYAZAKI	10. 07. 22	WRITTEN	AH. MIYAZAKI	10. 07. 22
技術指定書 TECHNICAL SPECIFICATION		ETAD-H0475		△ 1 / 7	

3-1-3: Push the entire surface of the plug straight down with even force.  
 To prevent incomplete mating, using a flat plate to push down or to make sure the complete insertion is recommended.

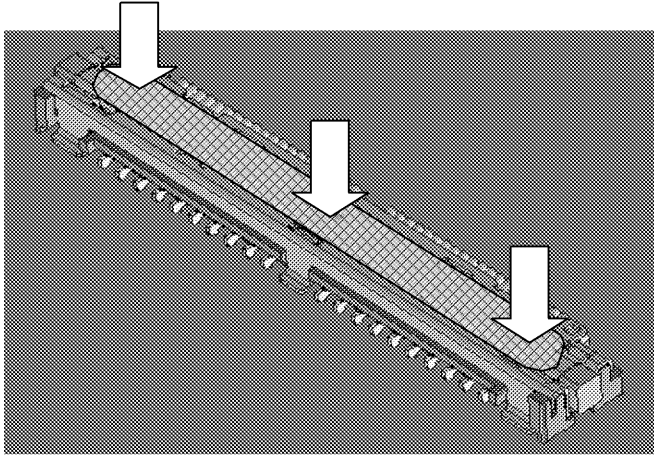

Incomplete mating could cause contact failure.

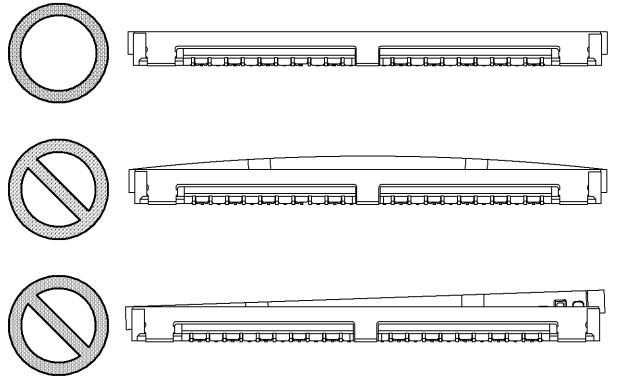

3-2.Extraction

3-2-1: Do not extract the plug by holding the cable. Otherwise, it causes damage of the connector and/or breakage of the cable.  
 Extraction with the tool specified bellow is recommended.

Product Name	Description
DF-SD3/RE-MD	Extracting tool

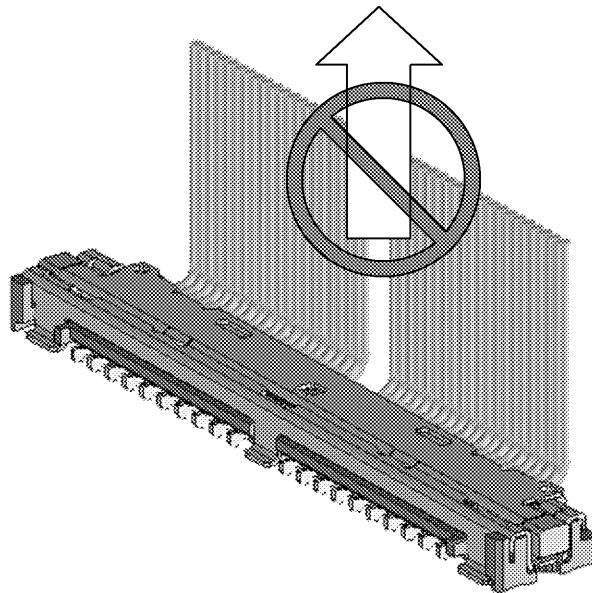

3-2-2: Insert the hook on the tool head into the gap between the plug and PCB from the side of the plug until the hook matches to the plug side face.

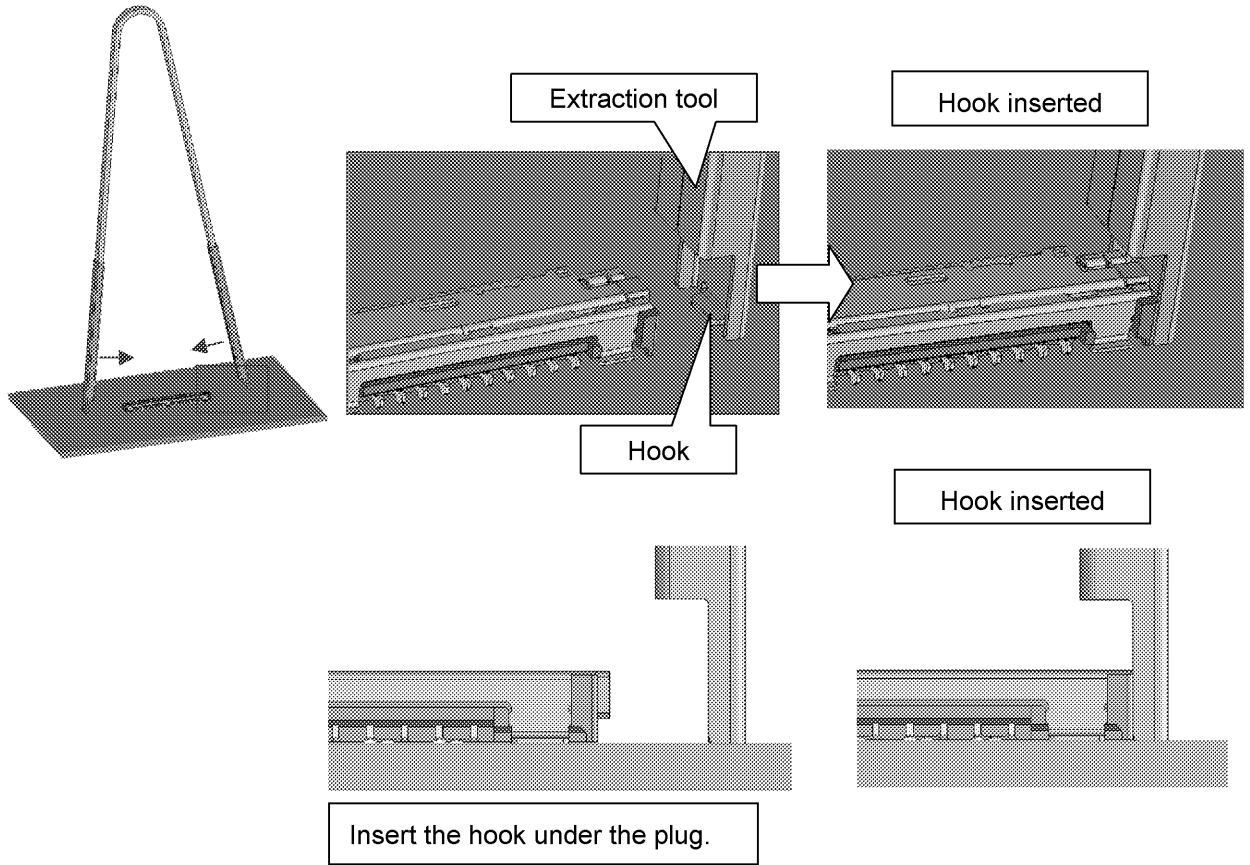

3-2-3: Remove the plug by pulling the tool straight up while the hook catches the plug.

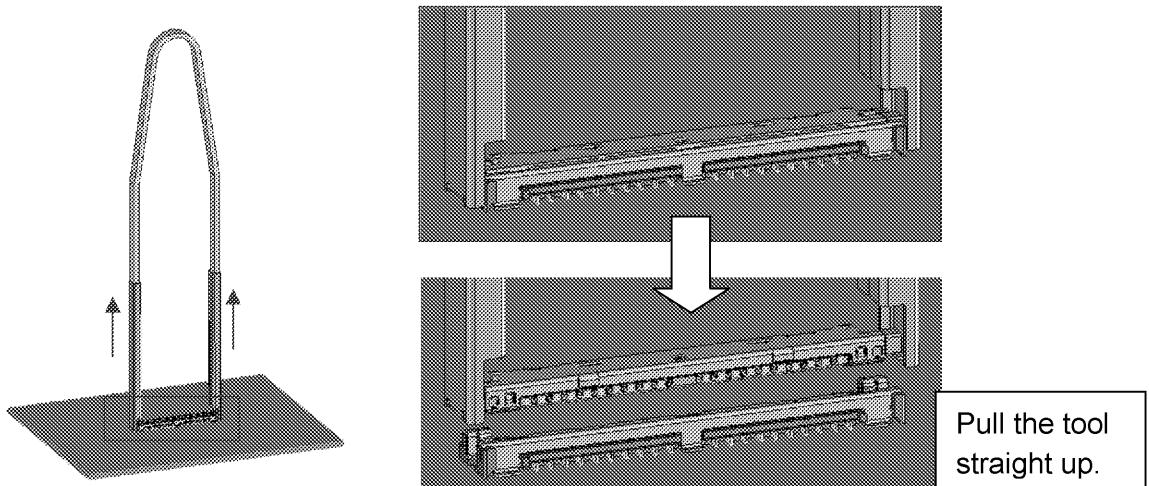

[Notes for extraction]

Do not pinch the connector with excessive force, or it could deform the connector.

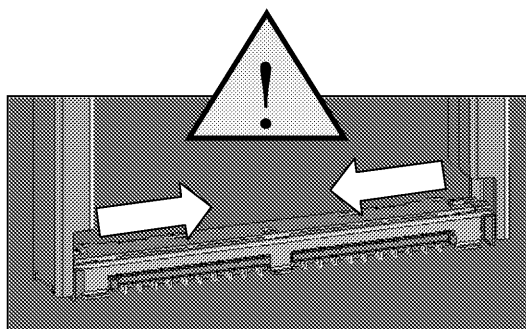

Do not extract the plug in tilted direction, or it could cause connector deformation.

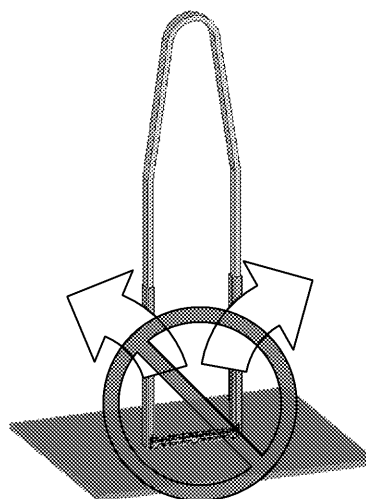
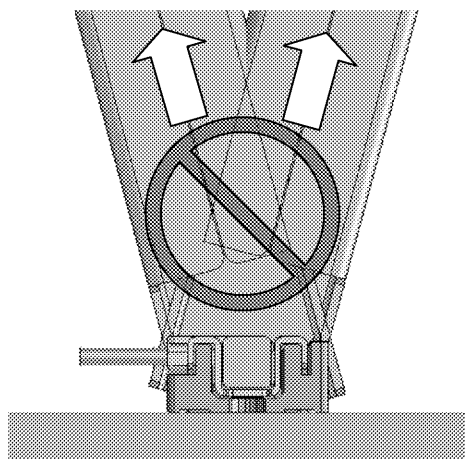

[Notes, Precautions]

1. Extraction tool is made of metal and has sharp hooks on its front edge.  
Please handle it with care to avoid injury.
2. This product is not applicable for hot-swap. Insertion/extraction operation shall be done while the power is switched off.

## Supplementation 1

1. Hirose designated tool shown below is recommended if DF-SD3/RE-MD is not used.

Product Name	Description
DF-SD2/RE-MD	Extracting tool

2. Insert the hook on the tool head into the gap between the plug and PCB from the side of the plug until the hook matches to the plug side face.

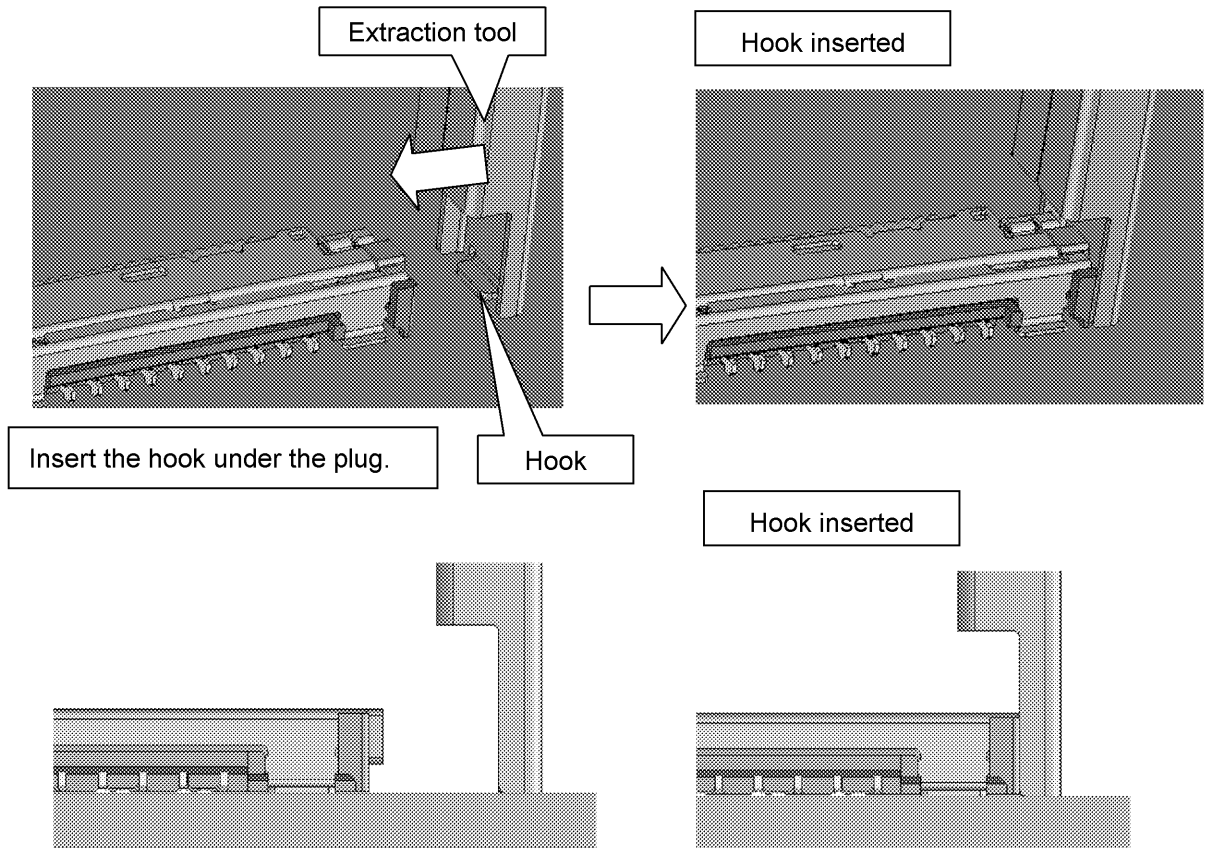

3. Remove the plug by pulling the tool straight up while the hook catches the plug.

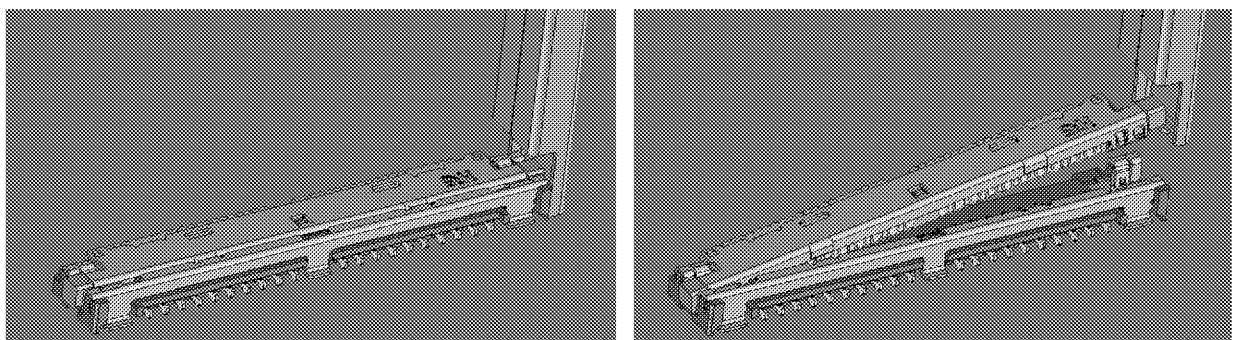

[Notes for extraction]

Do not extract the plug in tilted direction, or it could cause connector deformation.

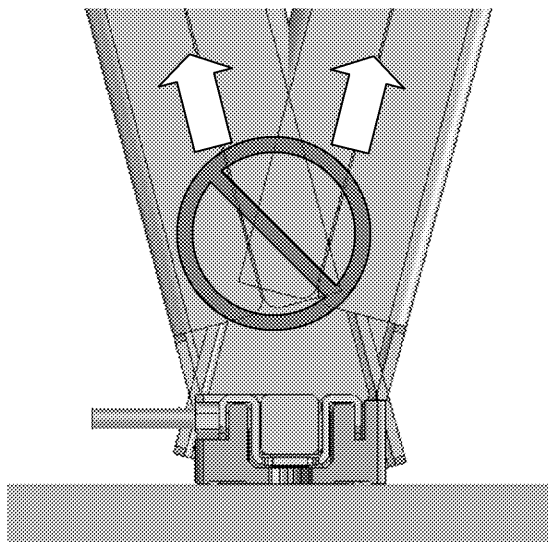

Connector could be damaged if mechanical stress is applied to the connector center direction as shown below.

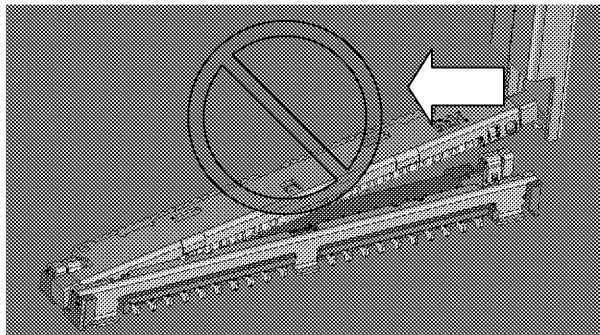

[Notes, Precautions]

1. Extraction tool is made of metal and has sharp hooks on its front edge.  
Please handle it with care to avoid injury.
2. This product is not applicable for hot-swap. Insertion/extraction operation shall be done while the power is switched off.

## Supplementation 2

Be careful when removing the plug by using finger as shown below, as nail could be broken or your finger could be injured.

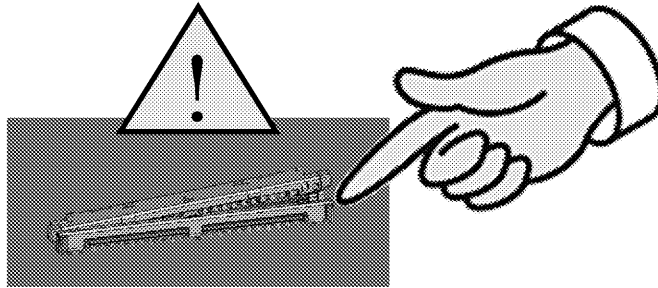

### [Notes, Precautions]

This product is not applicable for hot-swap. Insertion/extraction operation shall be done while the power is switched off.