

Jun.1.2024 Copyright 2024 HIROSE ELECTRIC CO., LTD. All Rights Reserved.
 In case of consideration for using Automotive equipment / device which demand high reliability, kindly contact our sales window correspondents.

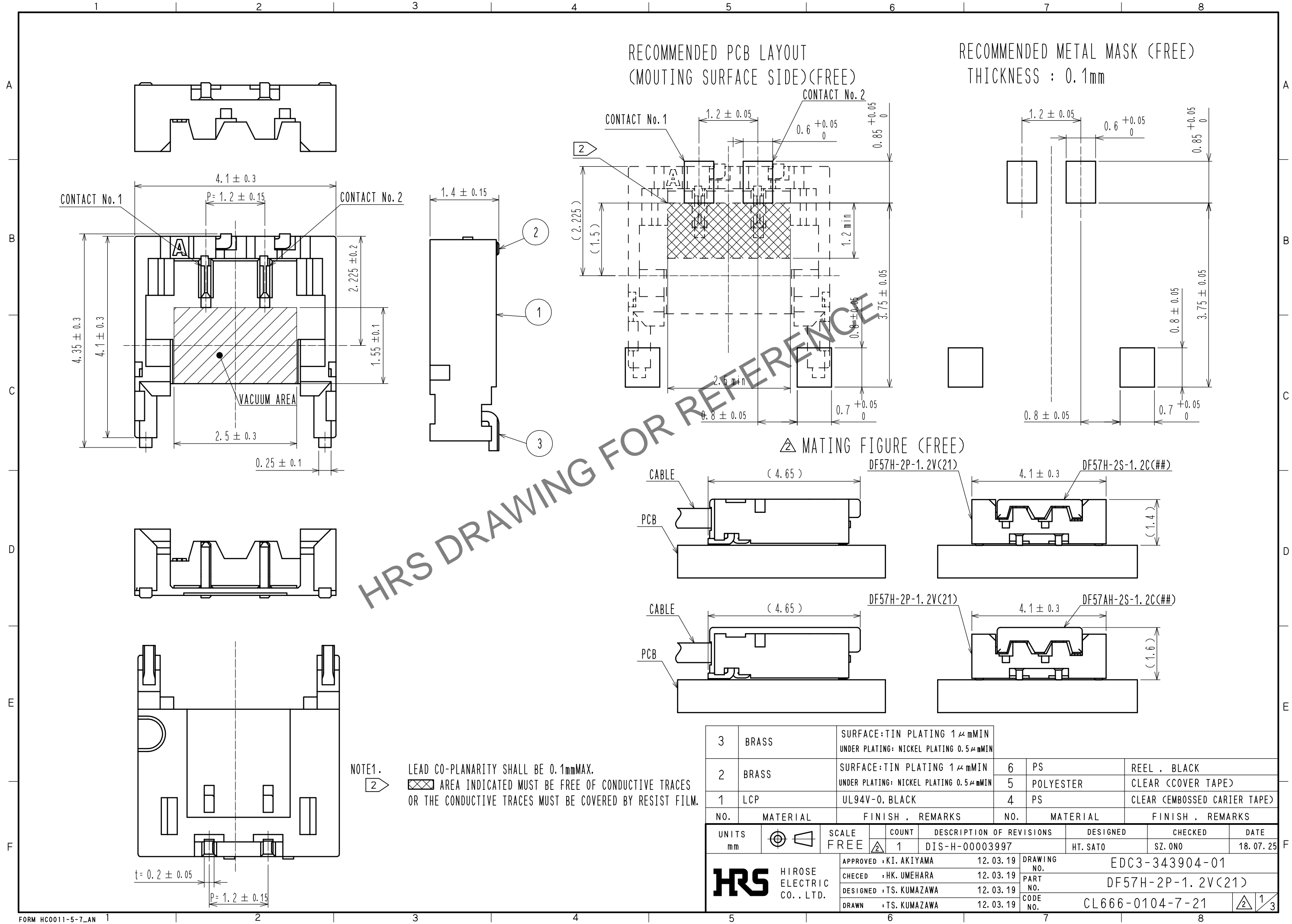

HRS DRAWING FOR REFERENCE

NOTE1. LEAD CO-PLANARITY SHALL BE 0.1mmMAX.
 [Hatched Area Symbol] AREA INDICATED MUST BE FREE OF CONDUCTIVE TRACES OR THE CONDUCTIVE TRACES MUST BE COVERED BY RESIST FILM.

3	BRASS	SURFACE: TIN PLATING 1 μmMIN UNDER PLATING: NICKEL PLATING 0.5 μmMIN	6	PS	REEL, BLACK
2	BRASS	SURFACE: TIN PLATING 1 μmMIN UNDER PLATING: NICKEL PLATING 0.5 μmMIN	5	POLYESTER	CLEAR (COVER TAPE)
1	LCP	UL94V-0, BLACK	4	PS	CLEAR (EMBOSSED CARRIER TAPE)
NO.	MATERIAL	FINISH, REMARKS	NO.	MATERIAL	FINISH, REMARKS
UNITS: mm		SCALE: FREE	COUNT: 1	DESCRIPTION OF REVISIONS: DIS-H-00003997	
DESIGNED: HT. SATO		CHECKED: SZ. ONO		DATE: 18.07.25	
APPROVED: KI. AKIYAMA		12.03.19		DRAWING NO.: EDC3-343904-01	
CHECKED: HK. UMEHARA		12.03.19		PART NO.: DF57H-2P-1.2V(21)	
DESIGNED: TS. KUMAZAWA		12.03.19		CODE NO.: CL666-0104-7-21	
DRAWN: TS. KUMAZAWA		12.03.19		1/3	

Jun.1.2024 Copyright 2024 HIROSE ELECTRIC CO., LTD. All Rights Reserved.
 In case of consideration for using Automotive equipment / device which demand high reliability, kindly contact our sales window correspondents.

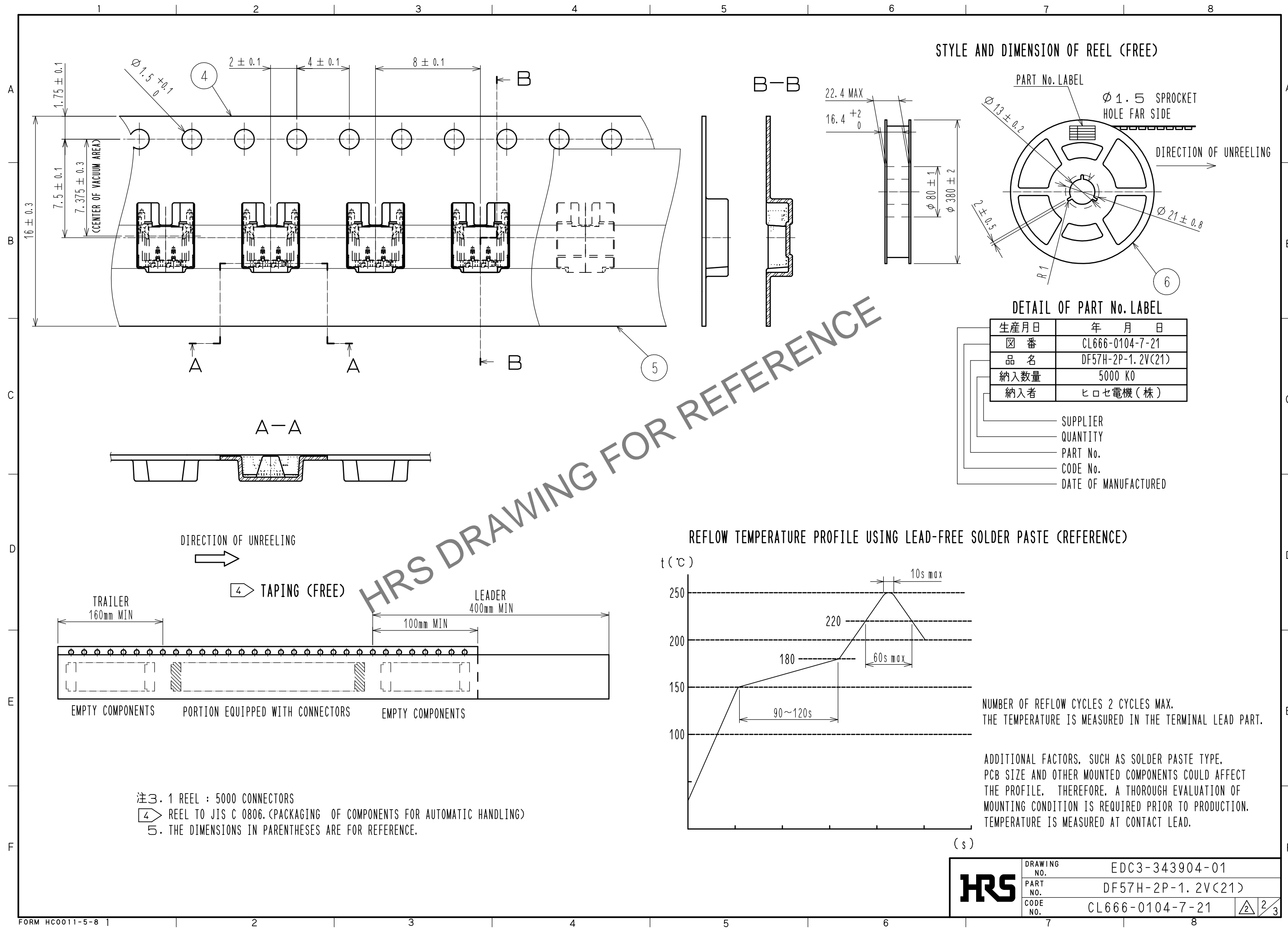

注3. 1 REEL : 5000 CONNECTORS
 4 REEL TO JIS C 0806.(PACKAGING OF COMPONENTS FOR AUTOMATIC HANDLING)
 5. THE DIMENSIONS IN PARENTHESES ARE FOR REFERENCE.

HRS DRAWING FOR REFERENCE

HRS	DRAWING NO.	EDC3-343904-01
	PART NO.	DF57H-2P-1.2V(21)
	CODE NO.	CL666-0104-7-21
		2/3

DF57 Series Mating / Unmating Operation Instruction

Mating

① By positioning the convexity of the socket sides to the header concavity, align the centers of the socket and the header in pitch direction.

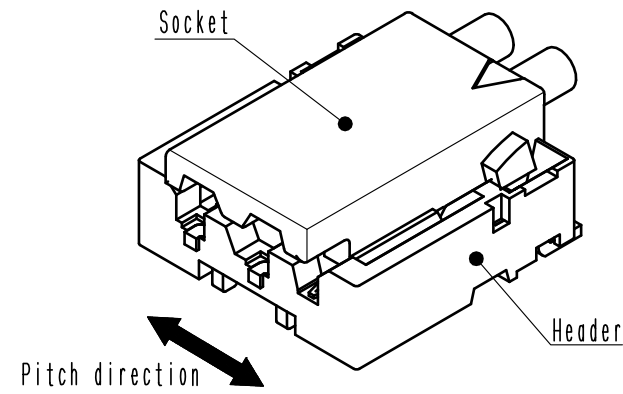

② Slightly press the socket down at cable side to tilted angle.

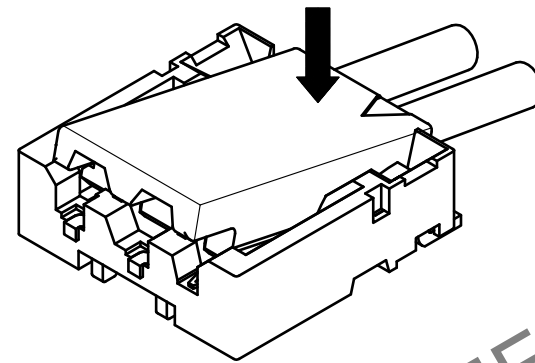

③ Press down at the lever side with stabilizing the cable side to insert. Mating completes.

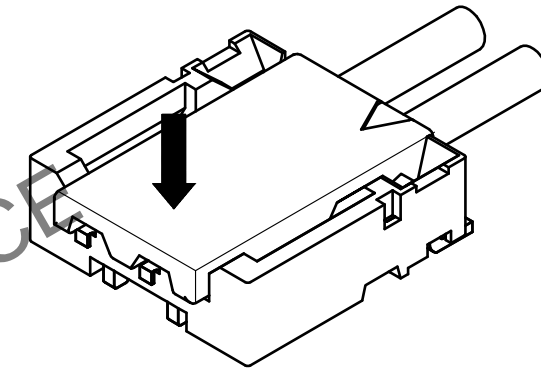

Unmating

① Hook the lever with finger nail.

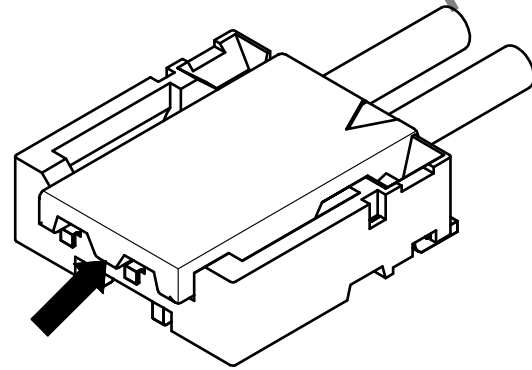

② Lift up to the upper direction and friction lock is released.

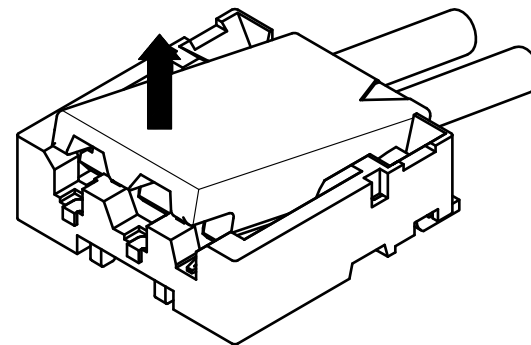

③ Lift up to the upper direction and positive lock is released. Removal completes.

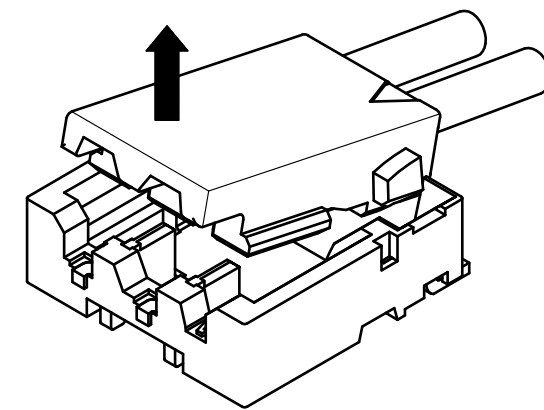

HRS

DRAWING NO.	EDC3-343904-01
PART NO.	DF57H-2P-1.2V(21)
CODE NO.	CL666-0104-7-21

3/3

Jun.1.2024 Copyright 2024 HIROSE ELECTRIC CO., LTD. All Rights Reserved. In case of consideration for using Automotive equipment / device which demand high reliability, kindly contact our sales window correspondents.

HRS DRAWING FOR REFERENCE