

Jun.1.2024 Copyright 2024 HIROSE ELECTRIC CO., LTD. All Rights Reserved.
In case of consideration for using Automotive equipment / device which demand high reliability, kindly contact our sales window correspondents.

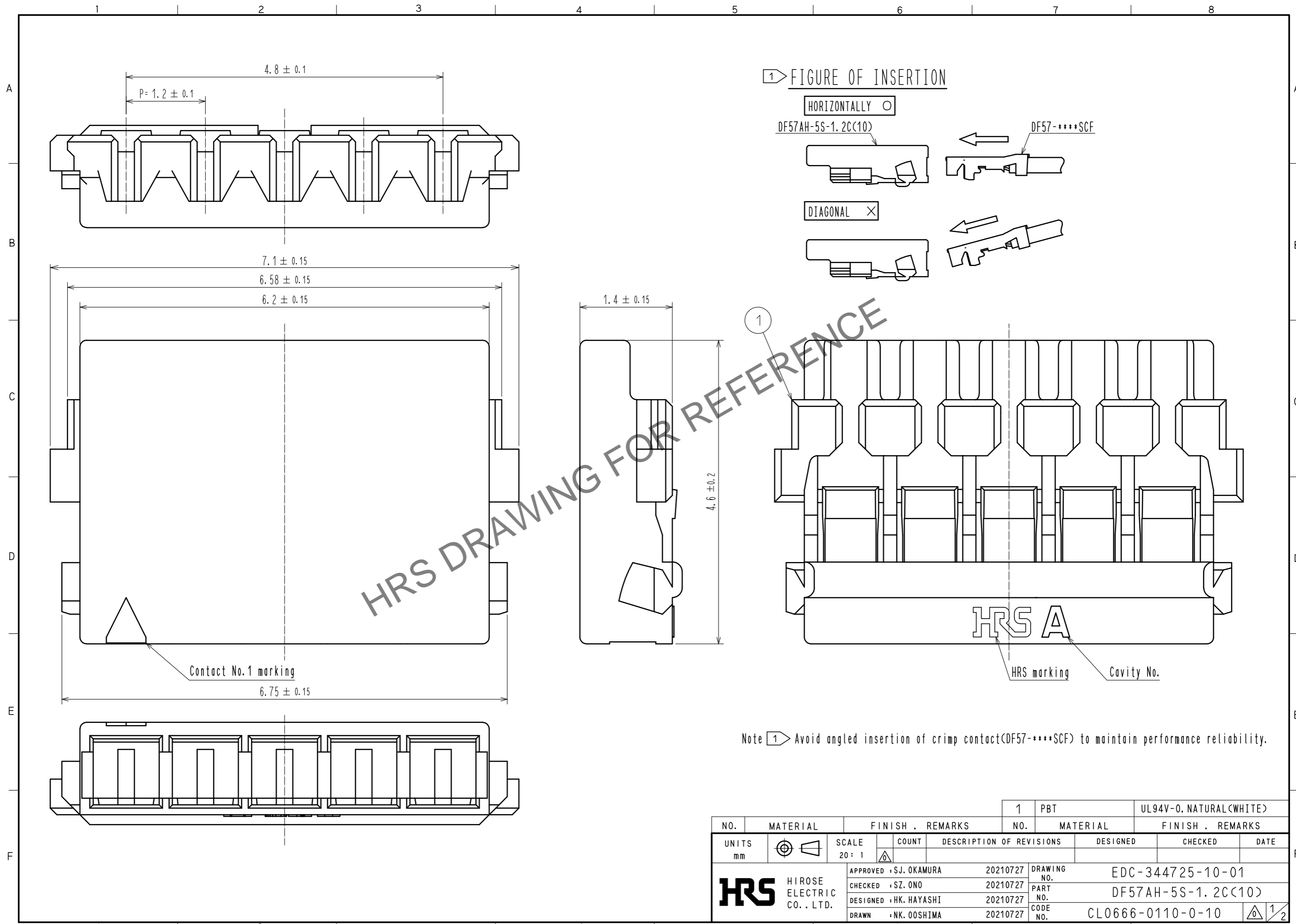

NO.	MATERIAL	FINISH . REMARKS	NO.	MATERIAL	FINISH . REMARKS		
1	PBT			UL94V-0. NATURAL(WHITE)			
UNITS	mm	SCALE	COUNT	DESCRIPTION OF REVISIONS	DESIGNED	CHECKED	DATE
		20:1	△				
HRS HIROSE ELECTRIC CO., LTD.		APPROVED : SJ. OKAMURA	20210727	DRAWING NO.	EDC-344725-10-01		
		CHECKED : SZ. ONO	20210727	PART NO.	DF57AH-5S-1.2C(10)		
		DESIGNED : HK. HAYASHI	20210727	CODE NO.	CL0666-0110-0-10		
		DRAWN : NK. OOSHIMA	20210727		△ 1/2		

DF57 Series Mating / Unmating Operation Instruction (For DF57 series)

Mating

① By positioning the convexity of the socket sides to the header concavity, align the centers of the socket and the header in pitch direction.

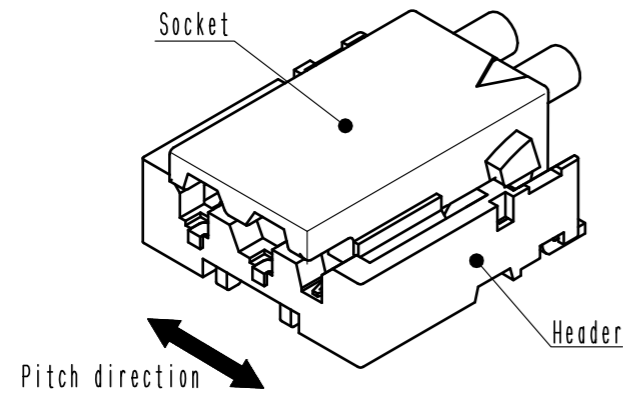

② Slightly press the socket down at cable side to tilted angle.

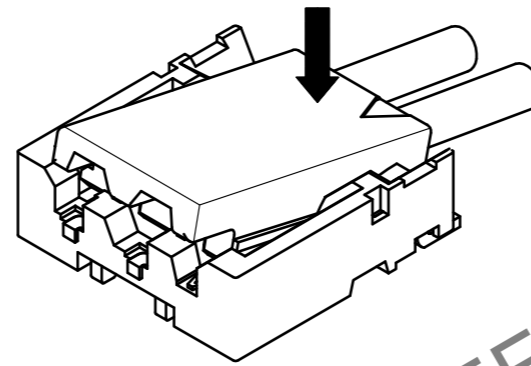

③ Press down at the lever side with stabilizing the cable side to insert. Mating completes.

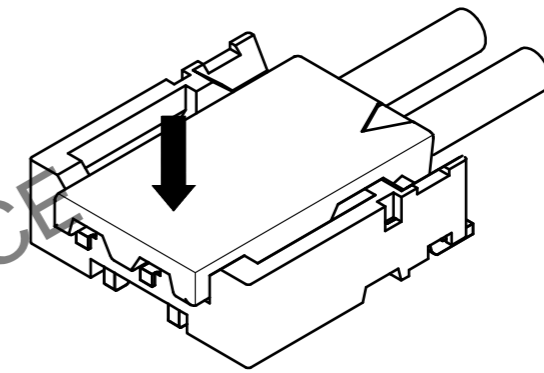

Unmating

① Hook the lever with finger nail.

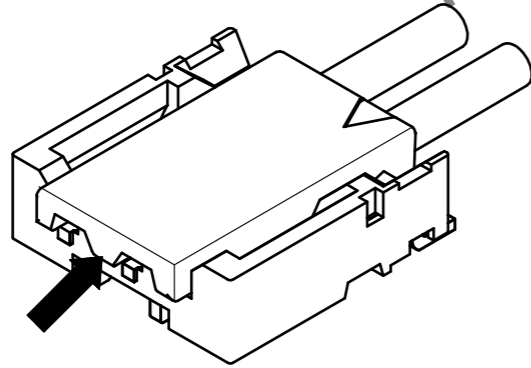

② Lift up to the upper direction and friction lock is released.

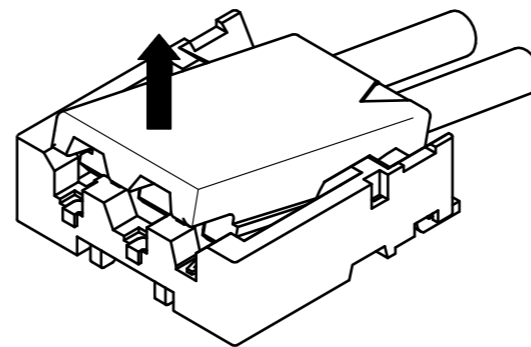

③ Lift up to the upper direction and positive lock is released. Removal completes.

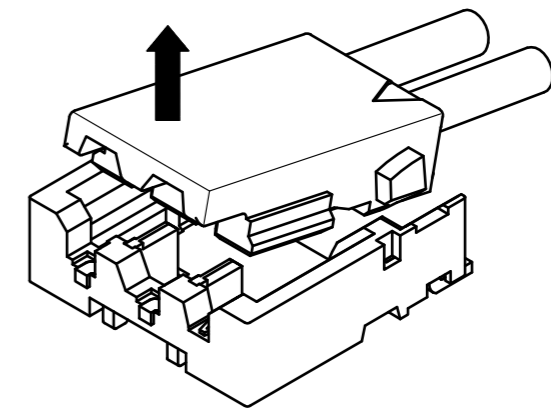

HRS DRAWING FOR REFERENCE

HRS	DRAWING NO.	EDC-344725-10-01
	PART NO.	DF57AH-5S-1.2C<10>
	CODE NO.	CL0666-0110-0-10
		2/2

In case of consideration for using Automotive equipment / device which demand high reliability, kindly contact our sales window correspondents.

Jun.1.2024 Copyright 2024 HIROSE ELECTRIC CO., LTD. All Rights Reserved.