

Jun.1.2024 Copyright 2024 HIROSE ELECTRIC CO., LTD. All Rights Reserved.  
 In case of consideration for using Automotive equipment / device which demand high reliability, kindly contact our sales window correspondents.

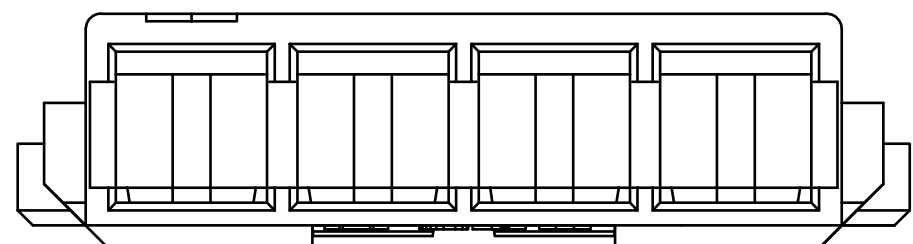
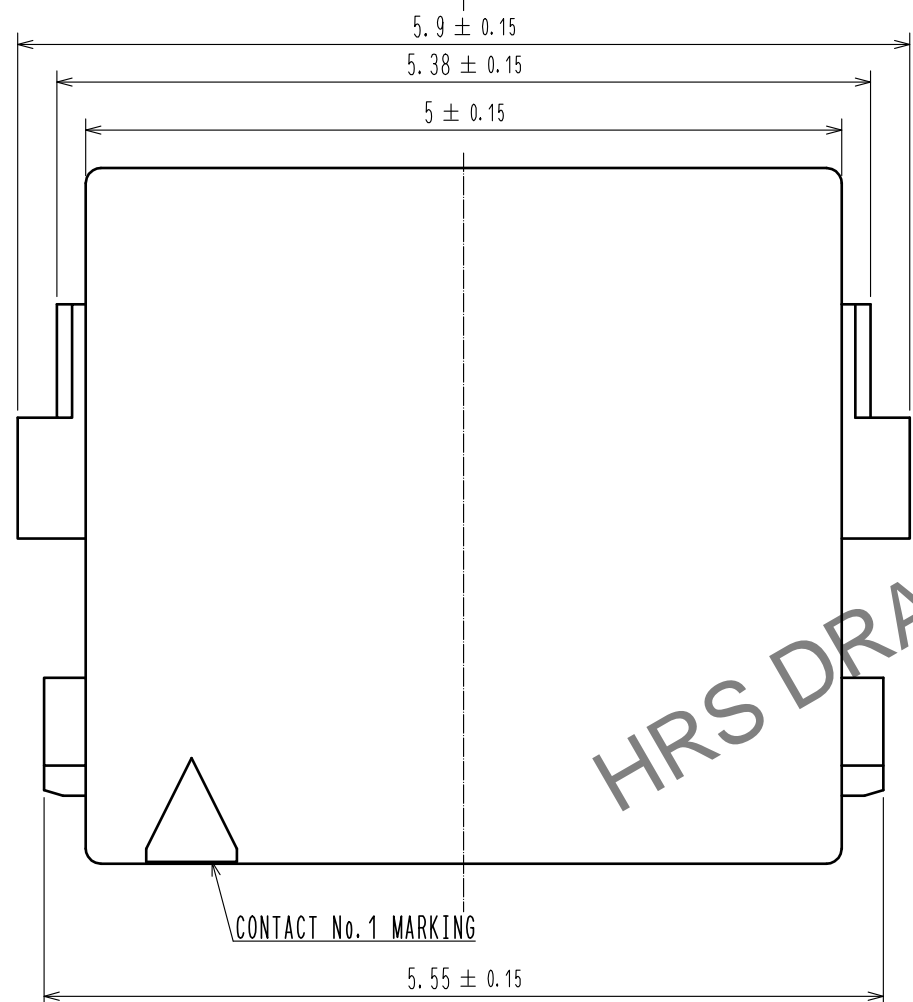
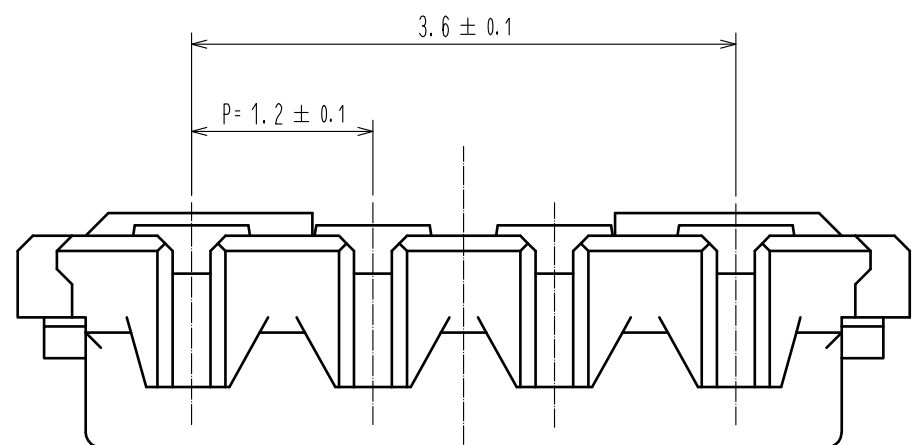

1 FIGURE OF INSERTION

HORIZONTALLY ○

DF57AH-4S-1.2C



DIAGONAL ×

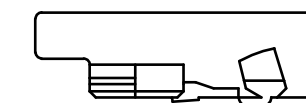

DF57-\*\*\*\*SCF

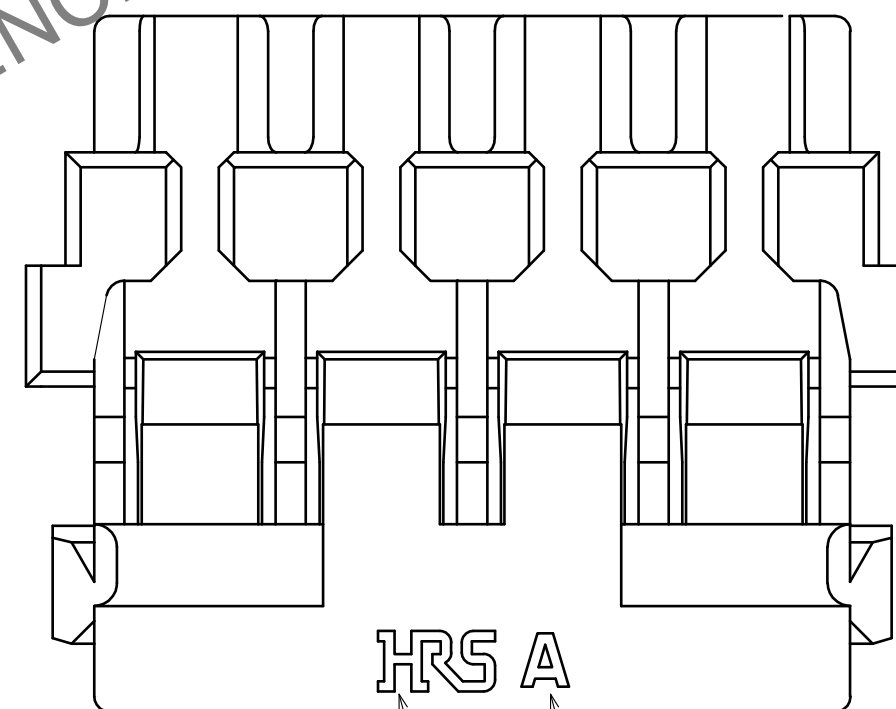
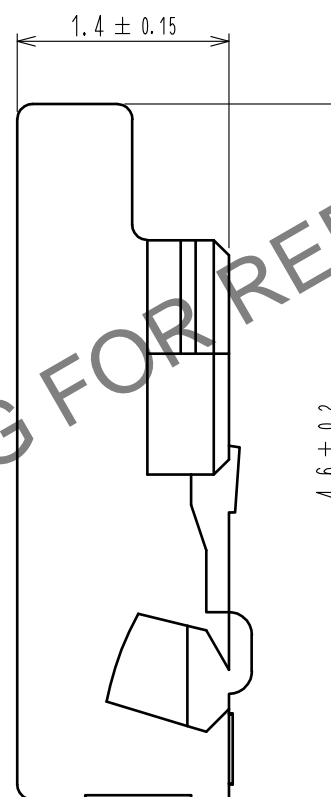
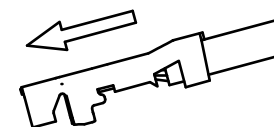
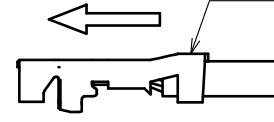

HRS A

HRS MARKING CAVITY No.

NOTE 1 AVOID ANGLED INSERTION OF CRIMP CONTACT(DF57-\*\*\*\*SCF) TO MAINTAIN PERFORMANCE RELIABILITY.

NO.	MATERIAL	FINISH . REMARKS	NO.	MATERIAL	FINISH . REMARKS
			1	PBT	UL94V-0. NATURAL(BLACK)
UNITS	mm	SCALE	20:1	COUNT	DESCRIPTION OF REVISIONS
		APPROVED	: HS. OKAWA	20190527	DRAWING NO.
		CHECKED	: SZ. ONO	20190527	PART NO.
		DESIGNED	: TO. KUROMATSU	20190527	CODE NO.
		DRAWN	: TO. KUROMATSU	20190527	
				EDC-387994-00-01	
				DF57AH-4S-1.2C	
				CL666-0113-0-00	
					1/2

# DF57 Series Mating / Unmating Operation Instruction

## Mating

① By positioning the convexity of the socket sides to the header concavity, align the centers of the socket and the header in pitch direction.

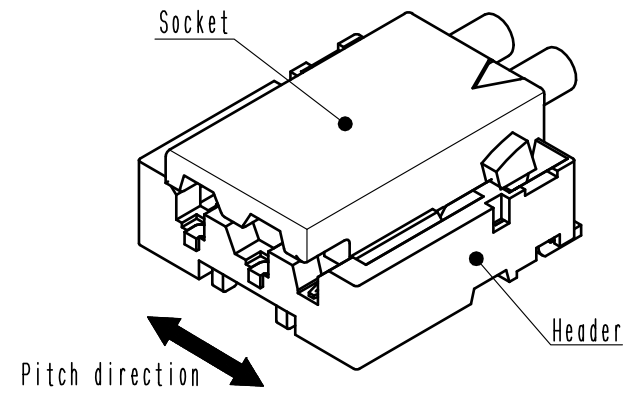

② Slightly press the socket down at cable side to tilted angle.

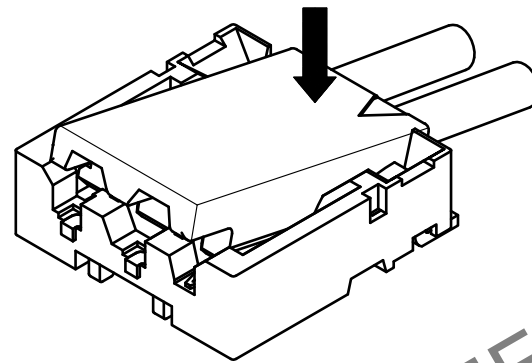

③ Press down at the lever side with stabilizing the cable side to insert. Mating completes.

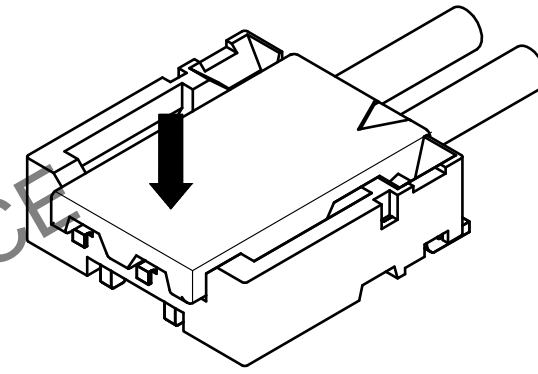

## Unmating

① Hook the lever with finger nail.

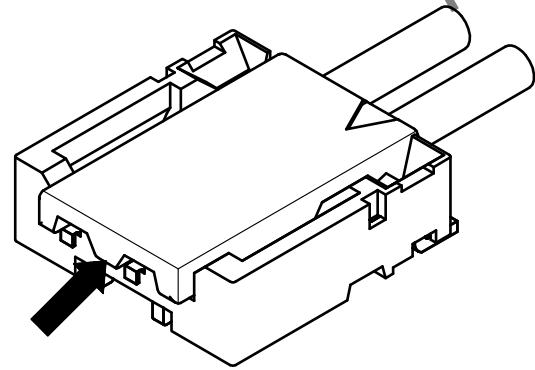

② Lift up to the upper direction and friction lock is released.

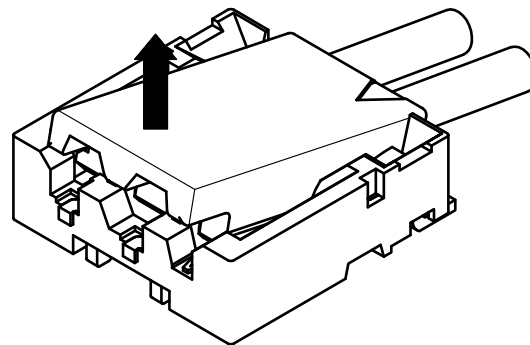

③ Lift up to the upper direction and positive lock is released. Removal completes.

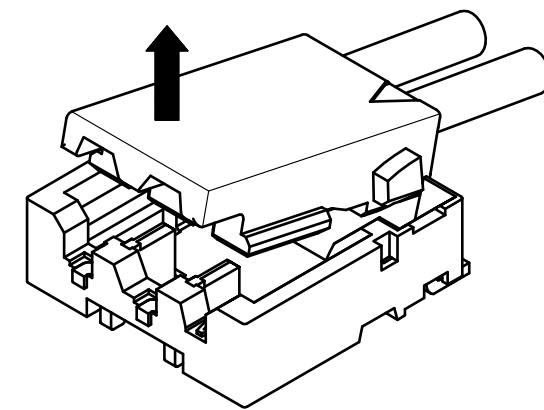

HRS DRAWING FOR REFERENCE

<b>HRS</b>	DRAWING NO.	EDC-387994-00-01	 2/2
	PART NO.	DF57AH-4S-1.2C	
	CODE NO.	CL666-0113-0-00	

Jun.1.2024 Copyright 2024 HIROSE ELECTRIC CO., LTD. All Rights Reserved. In case of consideration for using Automotive equipment / device which demand high reliability, kindly contact our sales window correspondents.