

May.1.2024 Copyright 2024 HIROSE ELECTRIC CO., LTD. All Rights Reserved.  
In case of consideration for using Automotive equipment / device which demand high reliability, kindly contact our sales window correspondents.

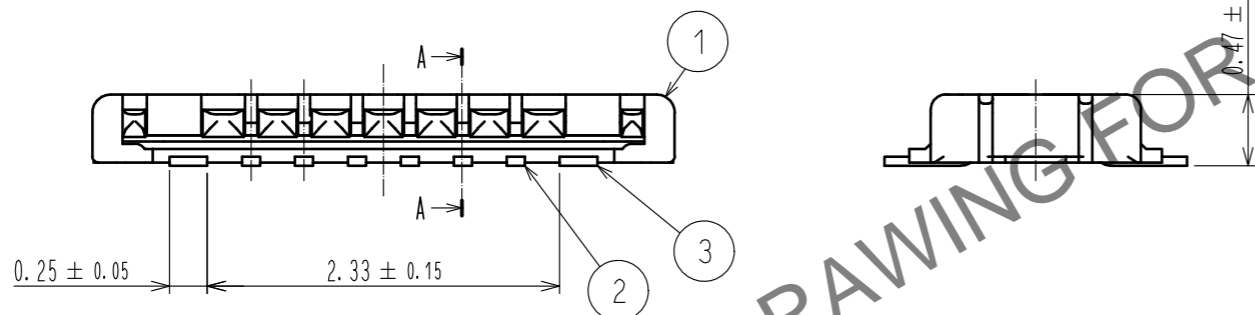
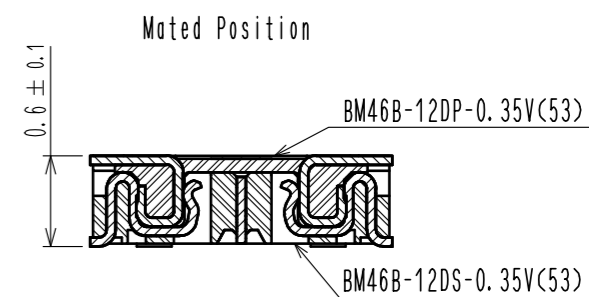
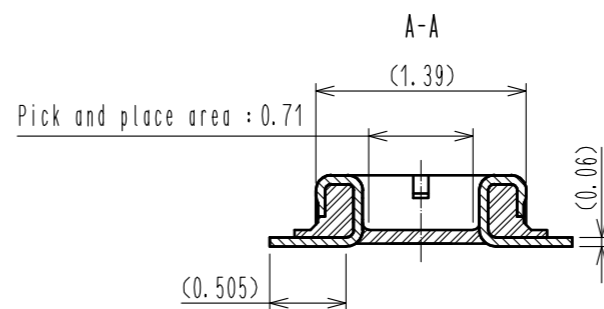
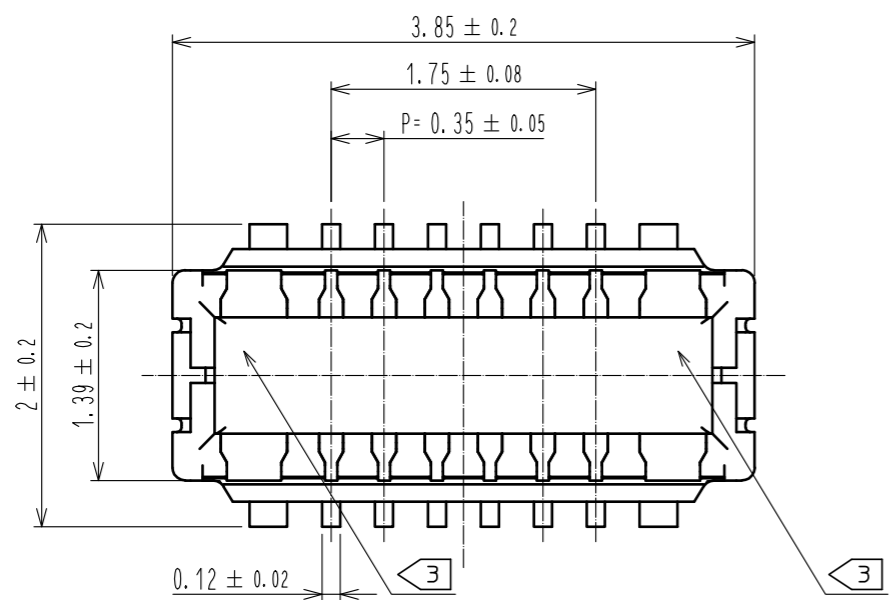

NOTE 1 . ALL LEAD CO-PLANARITY SHALL BE 0.08mm MAX.  
 2 CONTACT PLATING SPECIFICATIONS  
 CONTACT AREA : GOLD 0.03 μm MIN  
 SMT LEAD : GOLD 0.03 μm MIN  
 UNDER PLATING : NICKEL 1 μm MIN  
 ( SURFACE : SEALING )  
 3 HRS MARK AND CAV No. ARE INDICATED IN APPROX. POSITION SHOWN.

HRS DRAWING FOR REFERENCE

4	PS	SMOKE GRAY. EMBOSSED CARRIER TAPE						
3	COPPER ALLOY	2	7	PS	CLEAR. REINFORCEMENT COLLAR			
2	COPPER ALLOY	2	6	PS	BLACK. PLASTIC REEL			
1	LCP	UL94 V-0. BLACK	5	POLYESTER	CLEAR. COVER TAPE			
NO.	MATERIAL	FINISH . REMARKS	NO.	MATERIAL	FINISH . REMARKS			
UNITS	⊙	SCALE	COUNT	DESCRIPTION OF REVISIONS		DESIGNED	CHECKED	DATE
mm		20 : 1	△					
HIROSE ELECTRIC CO., LTD.		APPROVED : WR. FUKUCHI	20191024	DRAWING NO.		EDC-378956-53-00		
		CHECKED : TS. MIYAZAKI	20191024	PART NO.		BM46B-12DP-0.35V(53)		
		DESIGNED : RH. KITAGAWA	20191024	CODE NO.		CL673-7055-0-53		
		DRAWN : RH. KITAGAWA	20191024			1/3		

May.1.2024 Copyright 2024 HIROSE ELECTRIC CO., LTD. All Rights Reserved.  
 In case of consideration for using Automotive equipment / device which demand high reliability, kindly contact our sales window correspondents.

RECOMMENDED PCB LAYOUT (10:1)

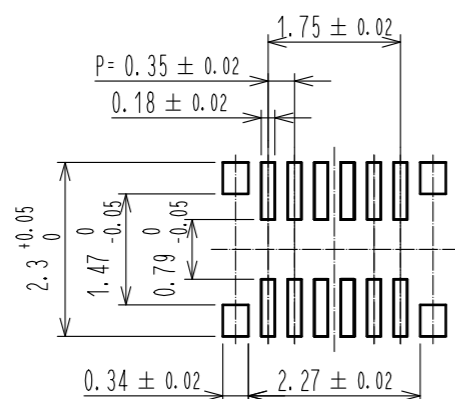

RECOMMENDED METAL MASK DIMENSIONS (10:1)  
 METAL MASK THICKNESS : 80 μm

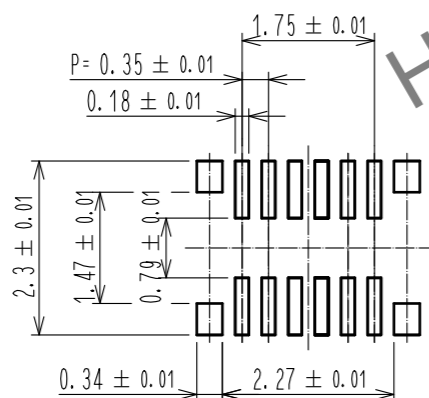

4 RECOMMENDED REFLOW TEMPERATURE PROFILE USING LEAD-FREE SOLDER PASTE.

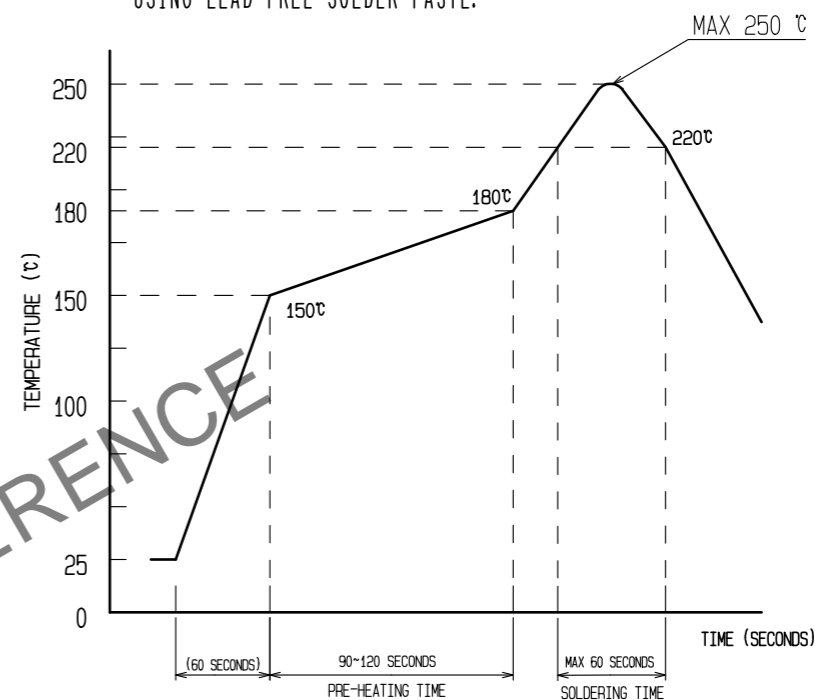

REFLOW METHOD:IR REFLOW  
 NUMBER OF REFLOW CYCLES:2 CYCLES MAX.  
 1)REFLOW TIME  
 DURATION ABOVE 220°C.60 SEC MAX.  
 (PEAK TEMPERATURE:250°C MAX)  
 2)PRE-HEAT TIME  
 PRE-HEAT TEMPERATURE(MIN):150°C  
 PRE-HEAT TEMPERATURE(MAX):180°C  
 PRE-HEAT TIME:90-120 SEC.

- 4 THIS TEMPERATURE PROFILE IS PER THE CONDITIONS SHOWN ABOVE. ADDITIONAL FACTORS, SUCH AS SOLDER PASTE TYPE, PCB SIZE AND OTHER MOUNTED COMPONENTS COULD AFFECT THE PROFILE. THEREFORE, A THOROUGH EVALUATION OF MOUNTING CONDITION IS REQUIRED PRIOR TO PRODUCTION. TEMPERATURE IS MEASURED AT CONTACT LEAD.
5. PLEASE CONTACT US IN CASE YOU WILL MAKE DIFFERENT SETTINGS FROM OUR RECOMMENDATION.
  6. THIS PRODUCT SATISFIES HALOGEN FREE REQUIREMENTS DEFINED AS 900ppm MAXIMUM CHLORINE, 900ppm MAXIMUM BROMINE, AND 1500ppm MAXIMUM TOTAL OF CHLORINE AND BROMINE.
  7. THIS PRODUCT COMPLY WITH RoHS.

<b>HRS</b>	DRAWING NO.	EDC-378956-53-00
	PART NO.	BM46B-12DP-0.35V(53)
	CODE NO.	CL673-7055-0-53

May.1.2024 Copyright 2024 HIROSE ELECTRIC CO., LTD. All Rights Reserved.  
In case of consideration for using Automotive equipment / device which demand high reliability, kindly contact our sales window correspondents.

# EMBOSSED CARRIER TAPE PACKAGING (5:1)

# STYLE AND DIMENSION OF REEL (FREE)

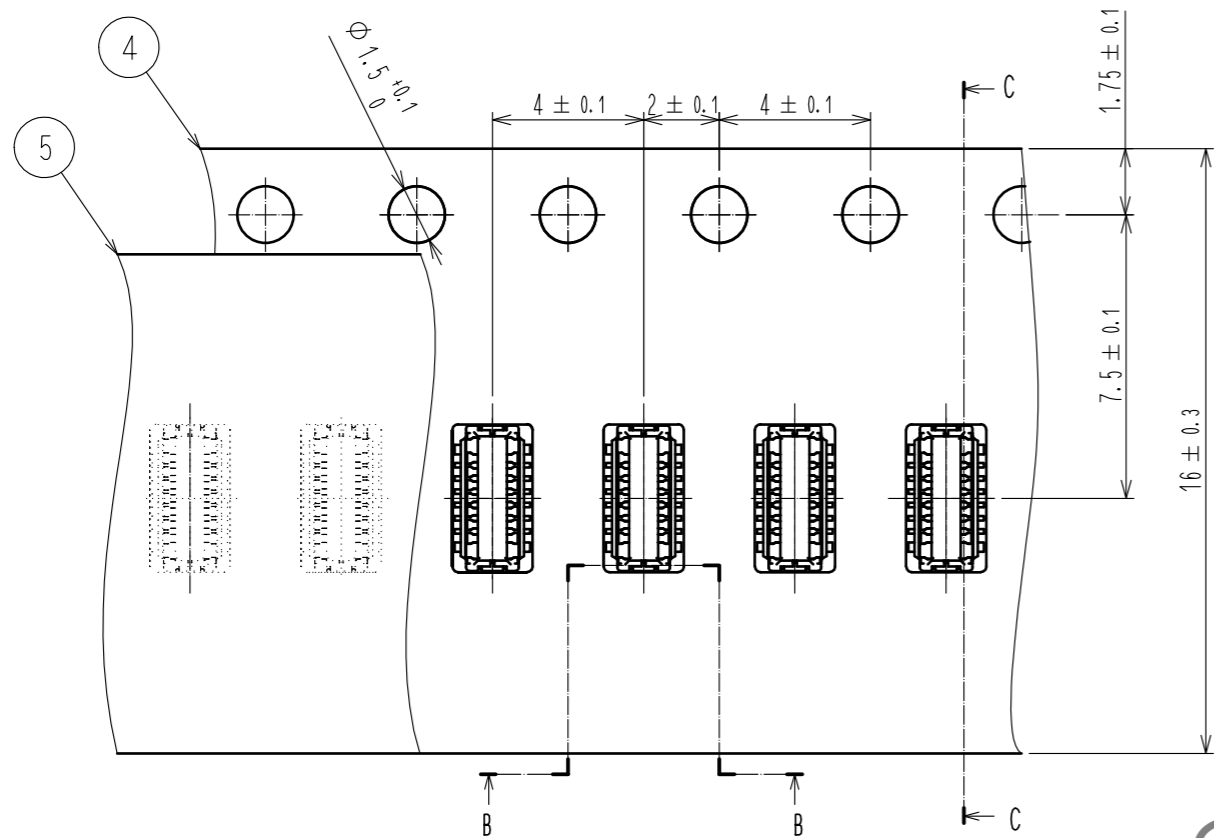

## C-C (5:1)

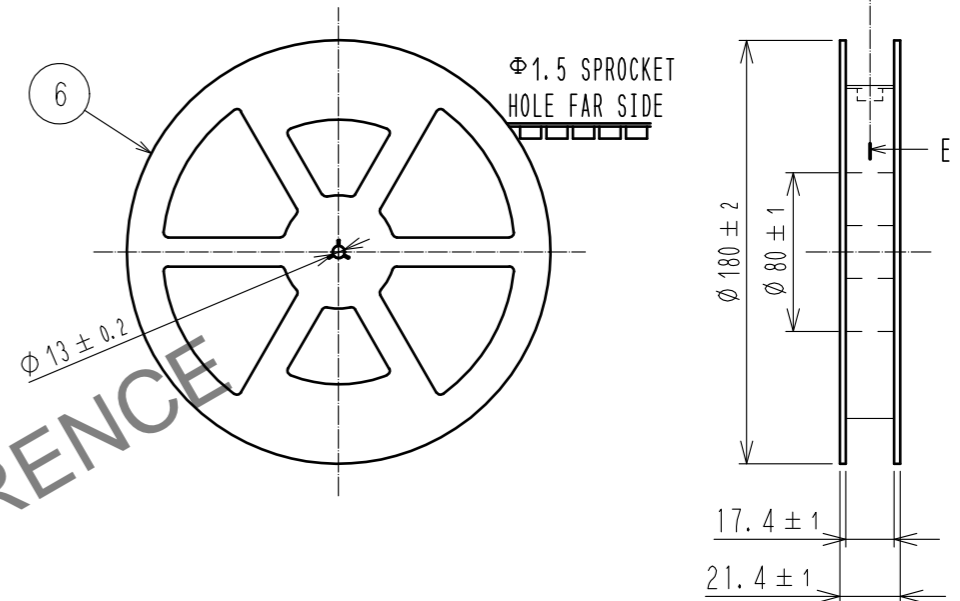
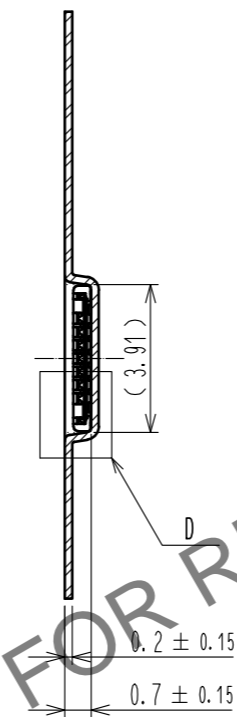

## E-E (FREE)

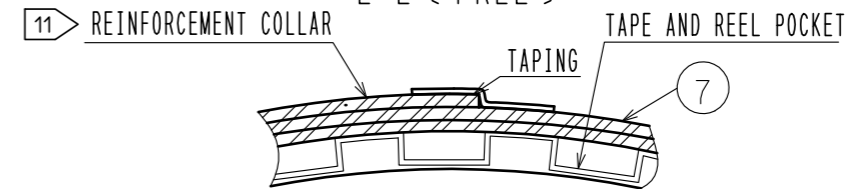

## B-B (5:1)

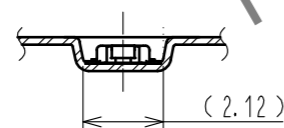

DIRECTION OF UNREELING

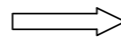

## D (10:1)

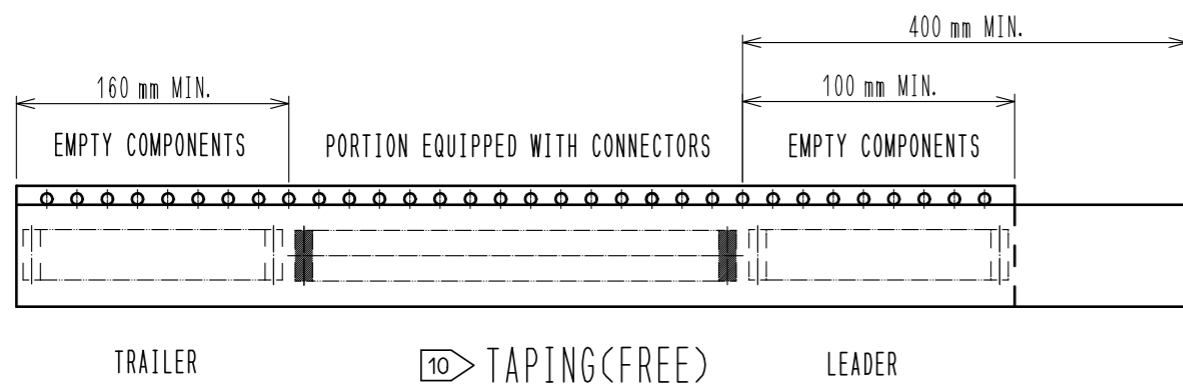
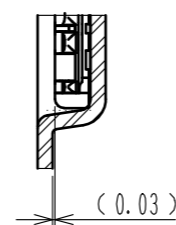

- 8 . PER REEL 1,000 CONNECTORS.
- 9 . THE DIMENSIONS IN PARENTHESES ARE FOR REFERENCE.
- 10 REFER TO IEC 60286-3 (PACKAGING OF COMPONENTS FOR AUTOMATIC HANDLING)
- 11 AFTER PACKAGING, ROLL 2 METERS OF THE REINFORCEMENT COLLAR TO OUTER CIRCUMFERENCE OF TAPE AND REEL POCKET, AND TAPE DOWN AT THE END THE COLLAR.

<b>HRS</b>	DRAWING NO.	EDC-378956-53-00
	PART NO.	BM46B-12DP-0.35V(53)
	CODE NO.	CL673-7055-0-53
		$\triangle$ 3/3