

May.1.2021 Copyright 2021 HIROSE ELECTRIC CO., LTD. All Rights Reserved.
In case of consideration for using Automotive equipment / device which demand high reliability, kindly contact our sales window correspondents.

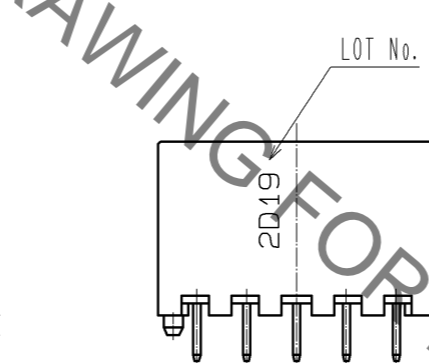

APPLICATION DIAGRAM

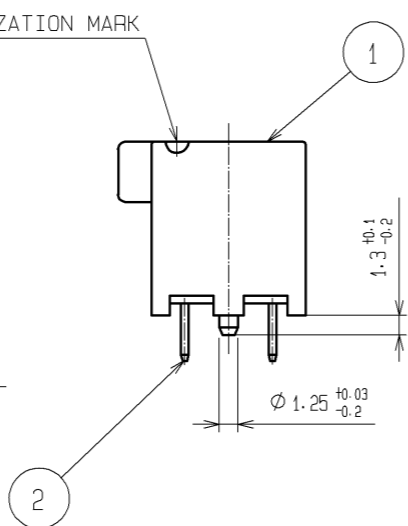
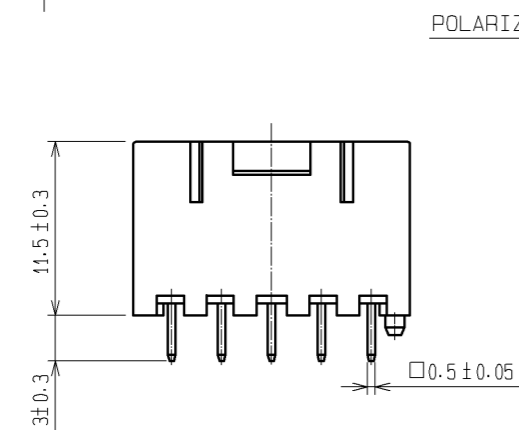
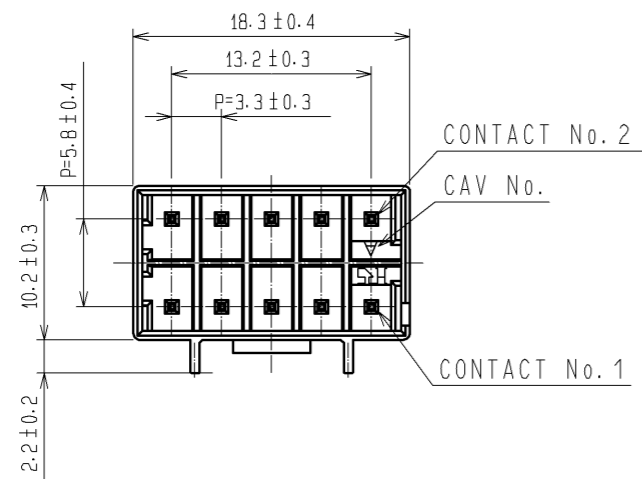
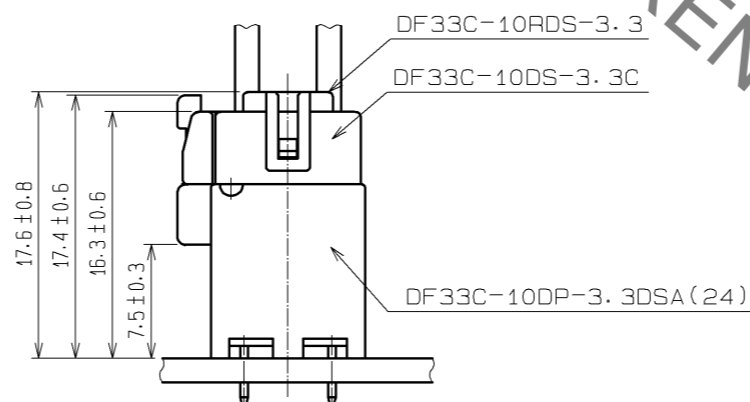
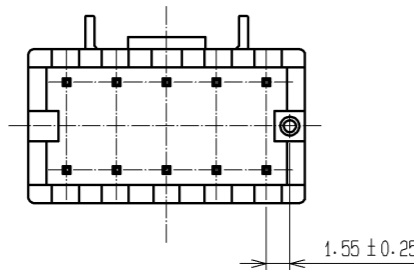

RECOMMENDED PATTERN(5:1)
(RECOMMENDED BOARD THICKNESS t=1.6mm)

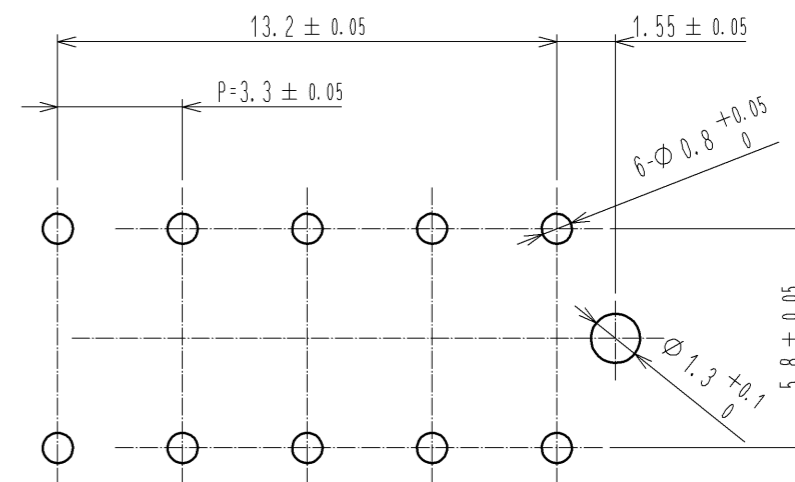

NOTES 1 : IMMERSION DEPTH INTO POTTING SOLUTION: 6.5mm

1	PBT	WHITE, UL94V-0	3	HIPS	TRAY			
2	BRASS		2	BRASS	SURFACE:TIN PLATED 1μm min UNDER PLATING:NICKEL PLATED 0.5μm min			
NO.	MATERIAL	FINISH, REMARKS	NO.	MATERIAL	FINISH, REMARKS			
UNITS	mm	SCALE	2:1	COUNT	DESCRIPTION OF REVISIONS	DESIGNED	CHECKED	DATE
HRS HIROSE ELECTRIC CO., LTD.		APPROVED : KI. AKIYAMA	13.03.11	DRAWING NO. EDC3-338390-02				
		CHECKED : TS. KUMAZAWA	13.03.11	PART NO. DF33C-10DP-3.3DSA(24)				
		DESIGNED : HT. SATO	13.03.11	CODE NO. CL676-1116-9-24				
		DRAWN : MI. SAKIMURA	13.03.08					

May.1.2021 Copyright 2021 HIROSE ELECTRIC CO., LTD. All Rights Reserved.
 In case of consideration for using Automotive equipment / device which demand high reliability, kindly contact our sales window correspondents.

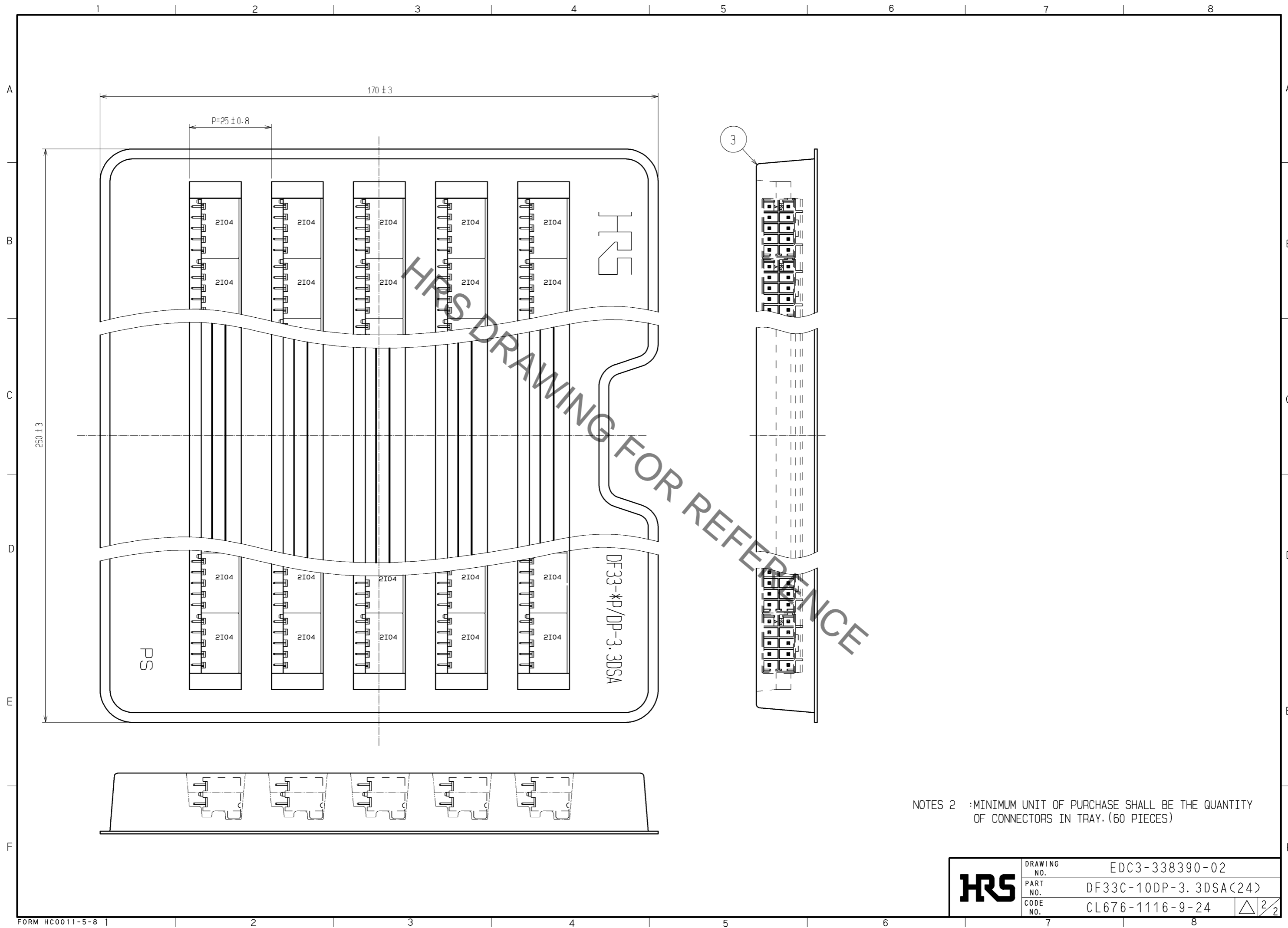

NOTES 2 :MINIMUM UNIT OF PURCHASE SHALL BE THE QUANTITY OF CONNECTORS IN TRAY. (60 PIECES)

HRS	DRAWING NO.	EDC3-338390-02	
	PART NO.	DF33C-10DP-3.3DSA(24)	
	CODE NO.	CL676-1116-9-24	△ 2/2