

Jun.1.2021 Copyright 2021 HIROSE ELECTRIC CO., LTD. All Rights Reserved.  
In case of consideration for using Automotive equipment / device which demand high reliability, kindly contact our sales window correspondents.

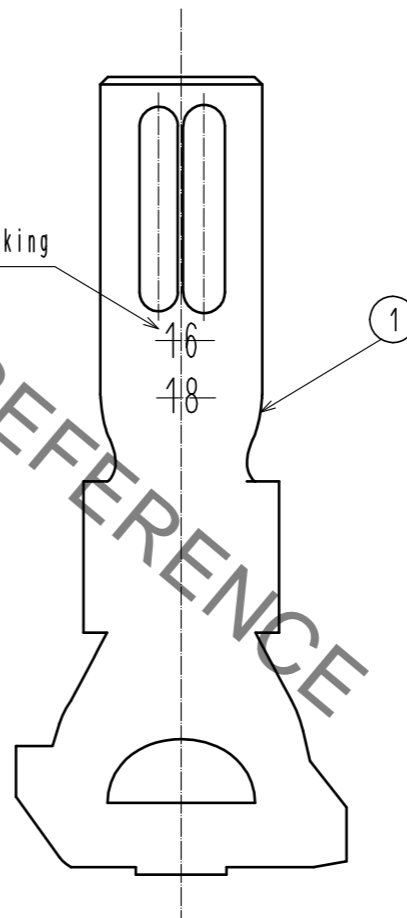

HRS DRAWING FOR REFERENCE

NOTE. 1. Per Pack : 100 Pieces.  
2. UL(File No. E52653)  
C-UL(File No. E52653)  
TUV(Certificate No. R50318850) authorization article.

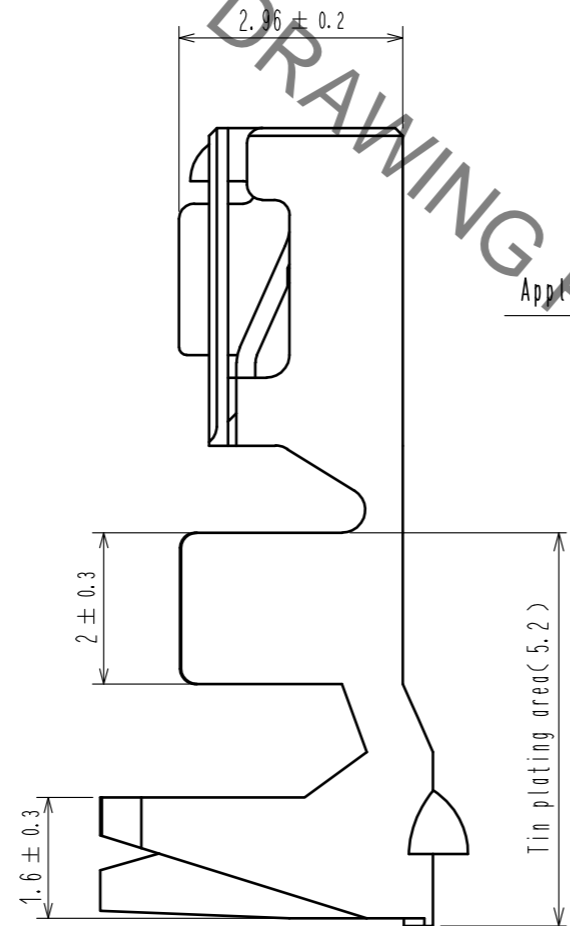
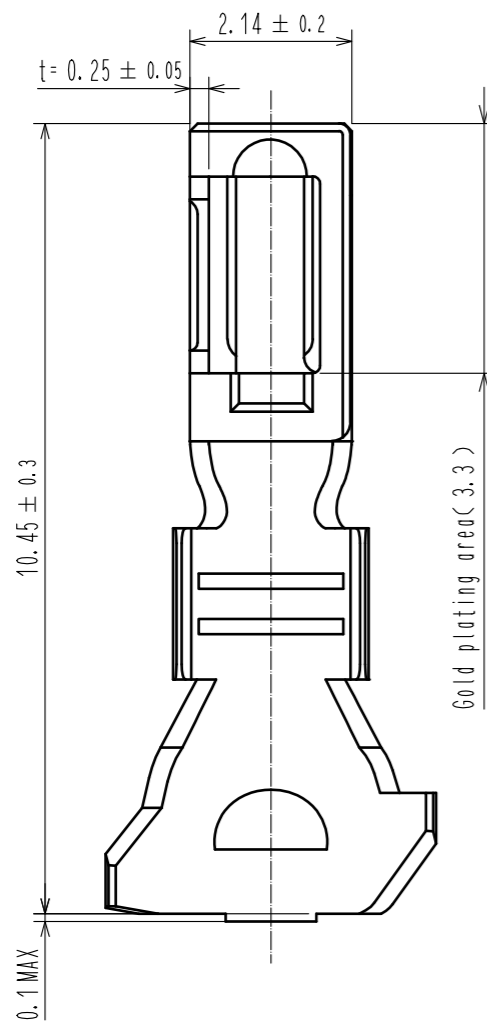
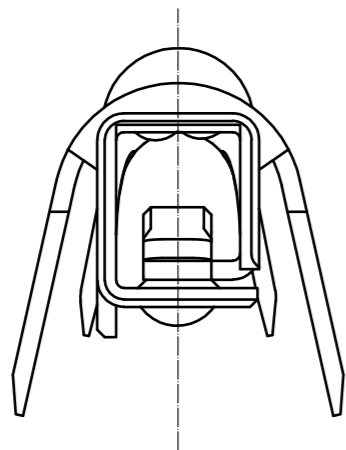

1	Copper alloy	Contact area: Gold plating 0.2 μm MIN Barrel area: Tin plating 1 μm MIN Under area: Nickel plating 1 μm MIN
---	--------------	---

NO.	MATERIAL	FINISH . REMARKS	NO.	MATERIAL	FINISH . REMARKS
UNITS mm		SCALE 10: 1	COUNT 	DESCRIPTION OF REVISIONS	
APPROVED : KI. AKIYAMA 15.11.04			DESIGNED	CHECKED	
CHECED : TS. FUKUSHIMA 15.11.02			DATE	DATE	
DESIGNED : YK. YAMAGUCHI 15.11.02			DRAWING NO.	EDC-362974-00-00	
DRAWN : HK. HAYASHI 15.11.02			PART NO.	DF63-1618SCA	
HRS HIROSE ELECTRIC CO., LTD.			CODE NO.	CL680-0542-0-00	
				1/1	