

Mar.1.2025 Copyright 2025 HIROSE ELECTRIC CO., LTD. All Rights Reserved.
In case of consideration for using Automotive equipment / device which demand high reliability, kindly contact our sales window correspondents.

1 2 3 4 5 6 7 8

A

B

C

D

E

F

A

B

C

D

E

F

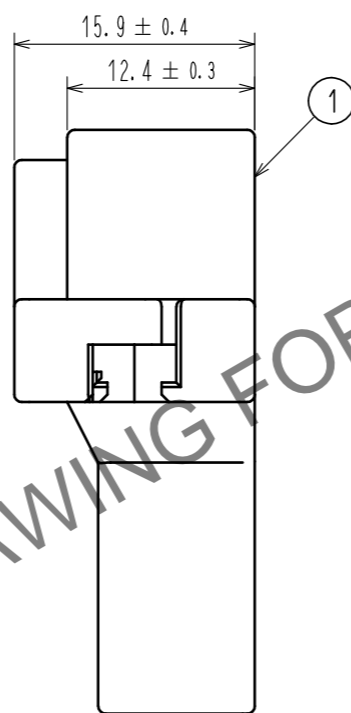
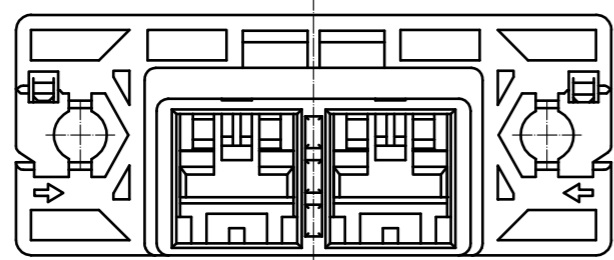
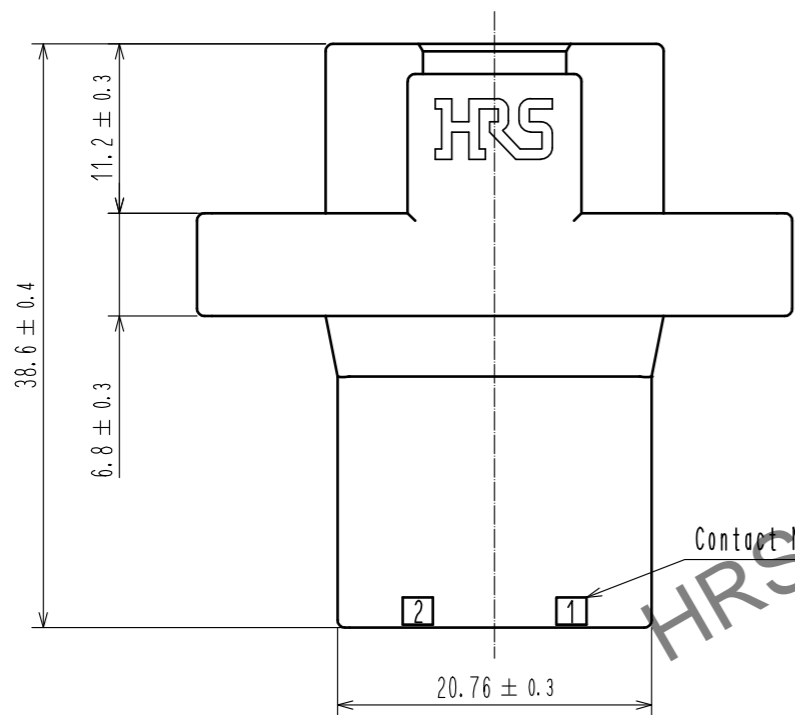
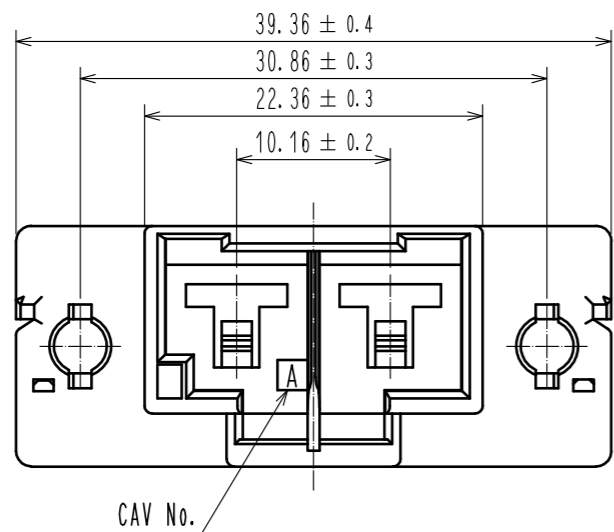

Recommended panel cut out dimension

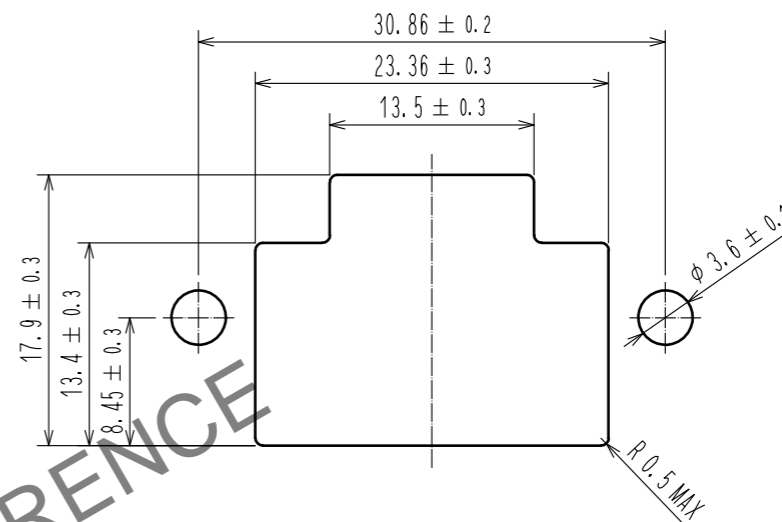

Mating figure

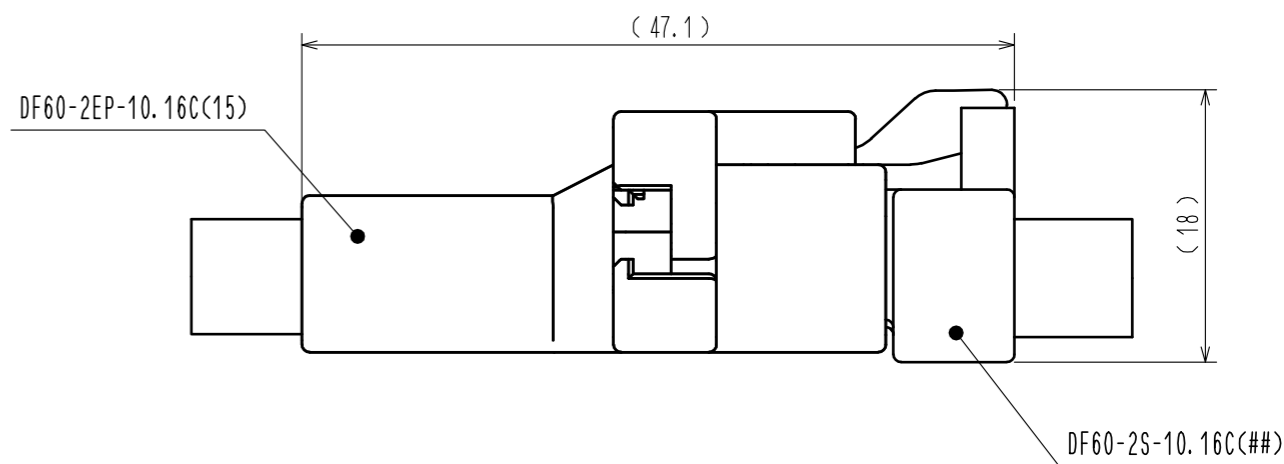

NOTE 1. Per pack : 100 pieces.

NO.		MATERIAL		FINISH . REMARKS		1	PBT	Red. UL94V-0
UNITS mm		SCALE 2 : 1		COUNT		DESIGNED		CHECKED
DESCRIPTION OF REVISIONS		DATE		DRAWING NO.		EDC-344821-15-00		
APPROVED : KI. AKIYAMA		15.01.19		PART NO.		DF60-2EP-10.16C(15)		
CHECKED : TS. FUKUSHIMA		15.01.17		CODE NO.		CL680-3025-5-15		
DESIGNED : TS. KUMAZAWA		15.01.17		DATE				
DRAWN : TS. KUMAZAWA		15.01.17						

Mar.1.2025 Copyright 2025 HIROSE ELECTRIC CO., LTD. All Rights Reserved.
In case of consideration for using Automotive equipment / device which demand high reliability, kindly contact our sales window correspondents.

DF60 In-Line type recommended panel mounting Manual (When nuts uses)

Nut installation process

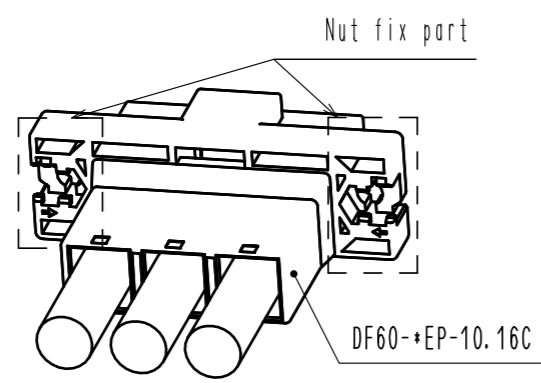

1. Slide a nut (Size:M3) to nut fix part.

2. Press down the nut until it clicks.
Then this sound means the nut has inserted into nut holder.

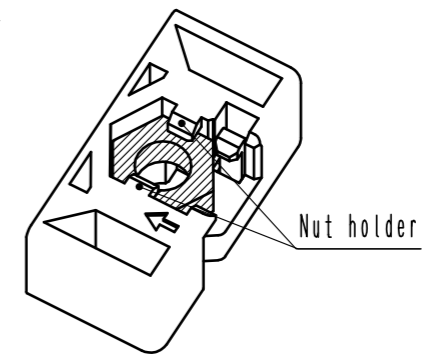
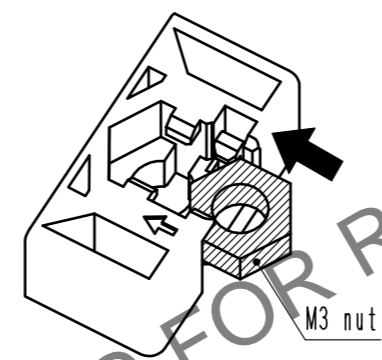

Panel mounting process

1. Insert connector into panel cut out part.

2. Tighten a screw (Size:M3) to fix with panel.
Recommended torque : Less than 49N · cm

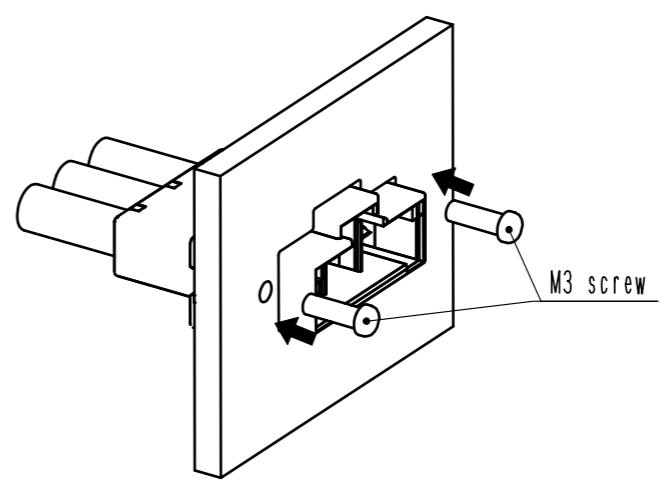
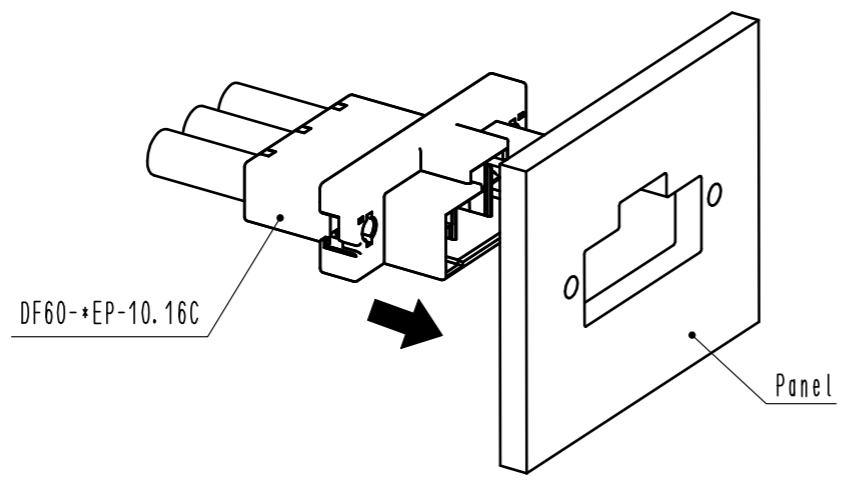

HRS	DRAWING NO.	EDC-344821-15-00
	PART NO.	DF60-2EP-10.16C(15)
	CODE NO.	CL680-3025-5-15
		2/2