

Apr.1.2024 Copyright 2024 HIROSE ELECTRIC CO., LTD. All Rights Reserved.
 In case of consideration for using Automotive equipment / device which demand high reliability, kindly contact our sales window correspondents.

Mating state figure

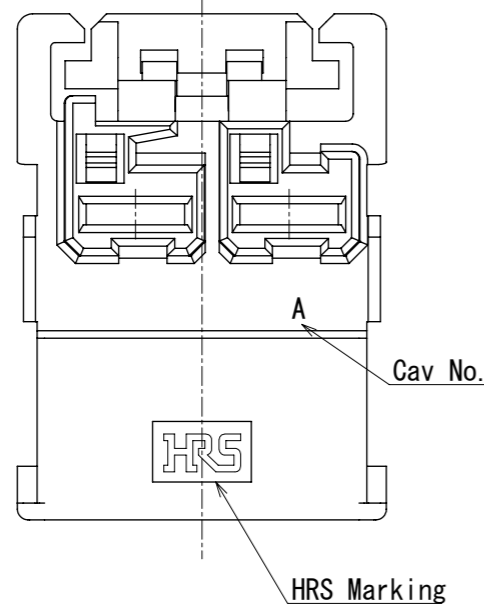

Straight for PCB

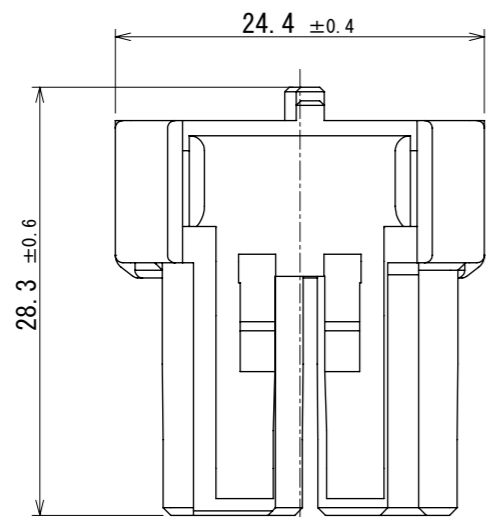
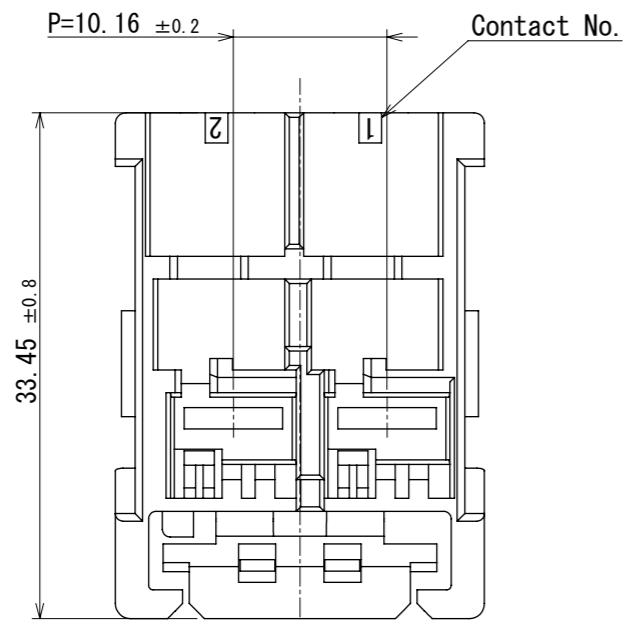
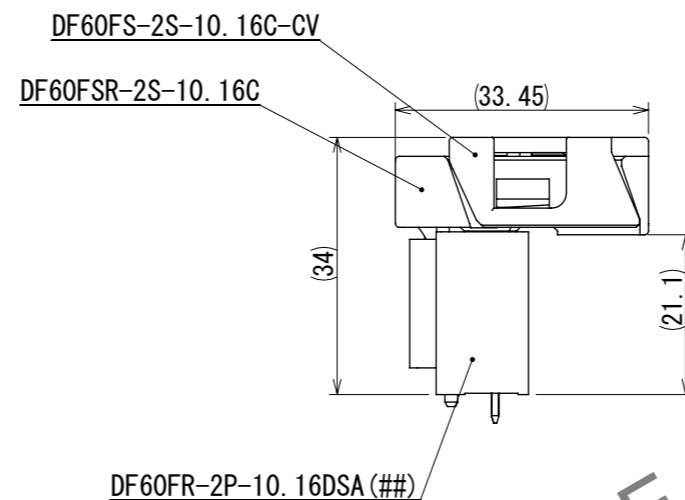

In-line

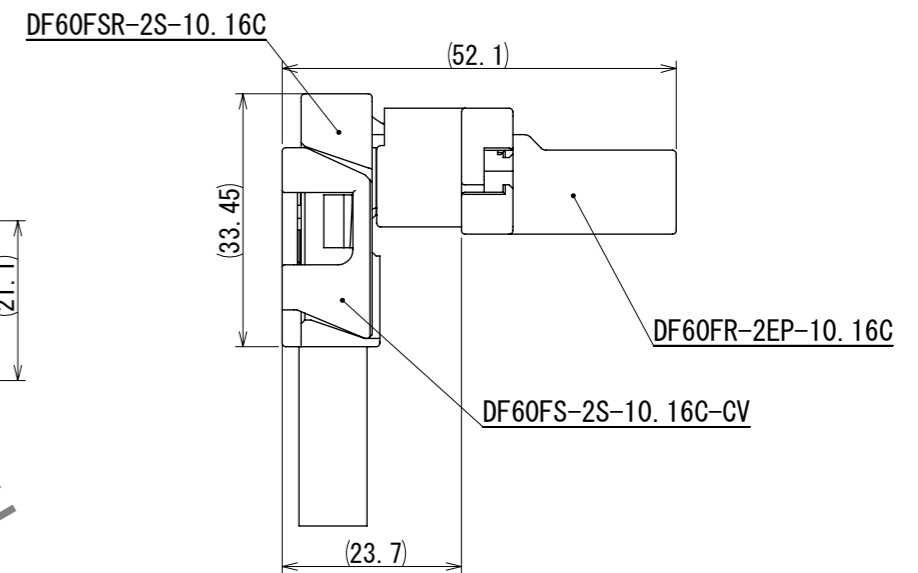

HRS DRAWING FOR REFERENCE

- Note 1. 100 Pieces / Pack
 2. Please refer to the technical specification (ETAP-H1020-00) for the packing type.
 3. Please refer to the technical specification (ETAD-H0654-00, ETAD-H0653-00) for handling.
 4. There may be minor scratches, however does not affect performance.

NO.	MATERIAL	FINISH	REMARKS
1	PBT	Red, UL94V-0	

UNITS	SCALE	COUNT	DESCRIPTION OF REVISIONS	DESIGNED	CHECKED	DATE
mm	2:1	△				
HIROSE ELECTRIC CO., LTD.		APPROVED	SJ. OKAMURA	2023. 10. 19	DRAWING NO. EDC-402757-00-00	
		CHECKED	TT. OHSAKO	2023. 10. 19	PART NO. DF60FSR-2S-10. 16C	
		DESIGNED	KT. NUMATA	2023. 10. 18	CODE NO. CL0680-4017-0-00	
		DRAWN	SK. CHIBA	2023. 10. 18		