

Apr.1.2026 Copyright 2026 HIROSE ELECTRIC CO., LTD. All Rights Reserved.
 In case of consideration for using Automotive equipment / device which demand high reliability, kindly contact our sales window correspondents.

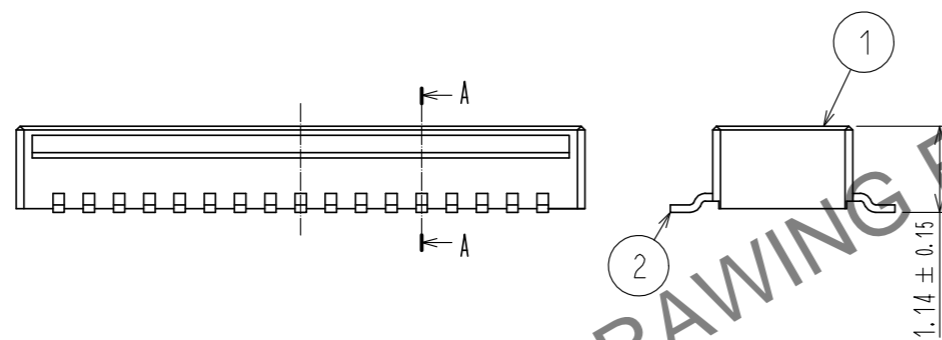

RECOMMENDED PATTERN

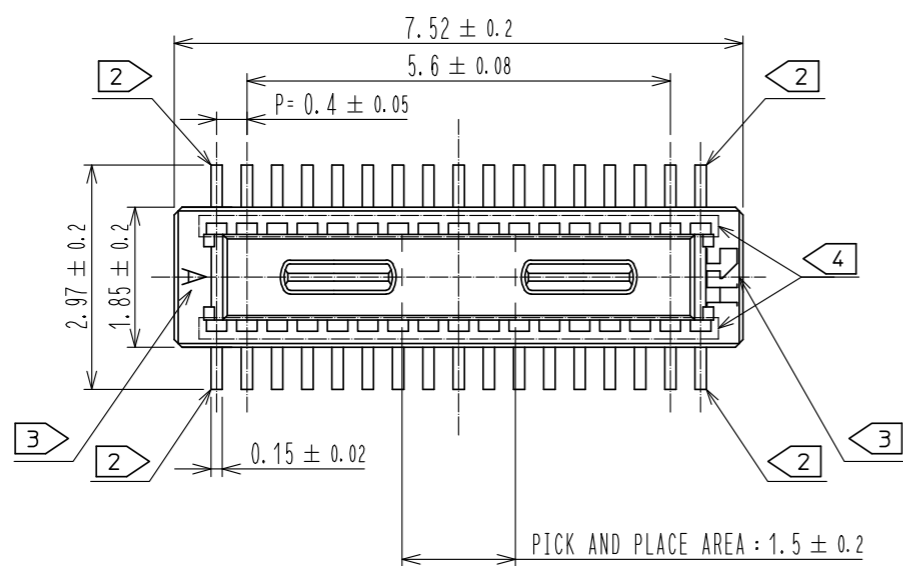
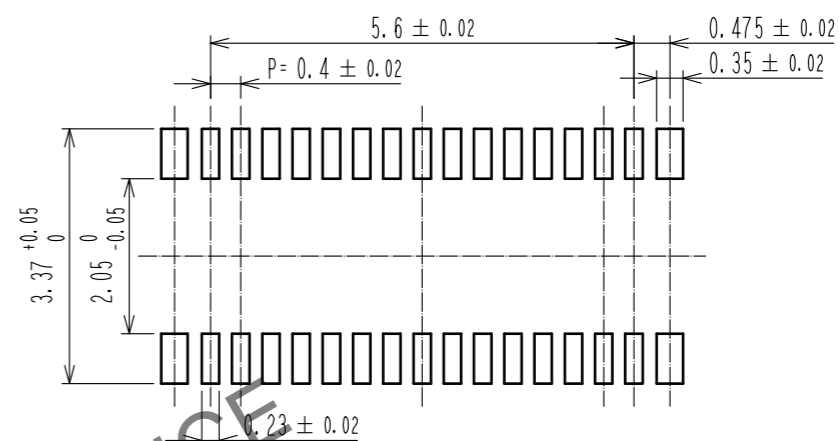

RECOMMENDED METAL MASK THICKNESS : 120 μm
 RECOMMENDED METAL MASK OPENING RATIO : 80% FOR LEAD PAD

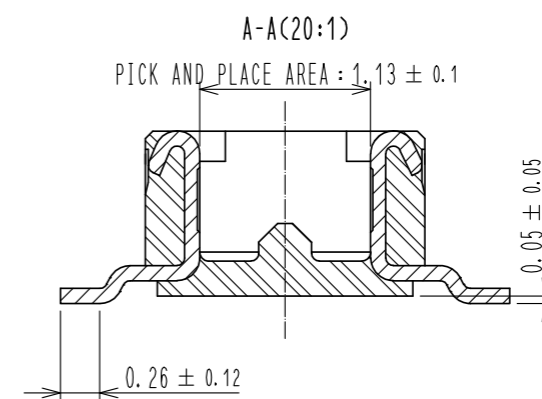

- NOTES
1. ALL LEADS CO-PLANARITY SHALL BE 0.1mm MAX.
 2. EACH ONE CONTACT AT 4 CORNERS SHALL BE USED AS METAL HOLD DOWN.
 3. HRS MARK AND CAV NO. IS INDICATED IN APPROXIMAL POSITION SHOWN. THE INDICATION COULD BE ON THE UPPER SURFACE OF DESIGN ON THE CONNECTOR.
 4. THERE IS A POSSIBILITY THAT THE RESIN WILL BE EXPOSED AT THIS AREA, BUT THIS WILL NOT AFFECT THE CONTACT RELIABILITY.

2	PHOSPHOR BRONZE	CONTACT AREA: Au 0.05 μm MIN	6	PS	CLEAR, REINFORCEMENT COLLAR		
		SMT LEAD: Au 0.05 μm MIN	5	PS	BLACK, PLASTIC REEL		
		UNDERPLATING: NICKEL 1 μm MIN	4	POLYESTER	CLEAR, COVER TAPE		
1	LCP	BLACK, UL94V-0	3	PS	CLEAR, EMBOSSED CARRIER TAPE		
NO.	MATERIAL	FINISH . REMARKS	NO.	MATERIAL	FINISH . REMARKS		
UNITS mm		SCALE 10:1	COUNT 2	DESCRIPTION OF REVISIONS DIS-H-00014841	DESIGNED TY. MORISHITA	CHECKED RT. SHIMIZU	DATE 20220824
HRS HIROSE ELECTRIC CO., LTD.		APPROVED : MO. ISHIDA 20150715	DRAWING NO. EDC-311344-58-01				
		CHECED : TS. MIYAZAKI 20150715	PART NO. DF40C-30DP-0.4V(58)				
		DESIGNED : SH. HOSODA 20150715	CODE NO. CL0684-4012-4-58				
		DRAWN : KR. AJITO 20150715					

Apr.1.2026 Copyright 2026 HIROSE ELECTRIC CO., LTD. All Rights Reserved.
 In case of consideration for using Automotive equipment / device which demand high reliability, kindly contact our sales window correspondents.

EMBOSSED CARRIER TAPE PACKING(5:1)

STYLE AND DIMENSION OF REEL(FREE)

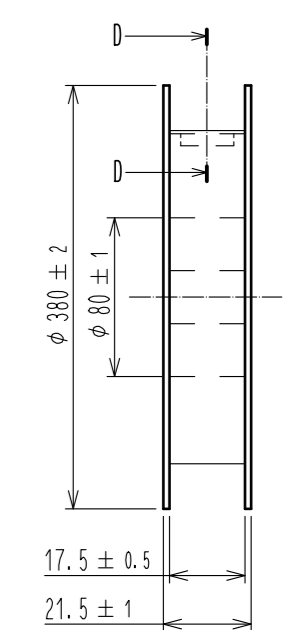
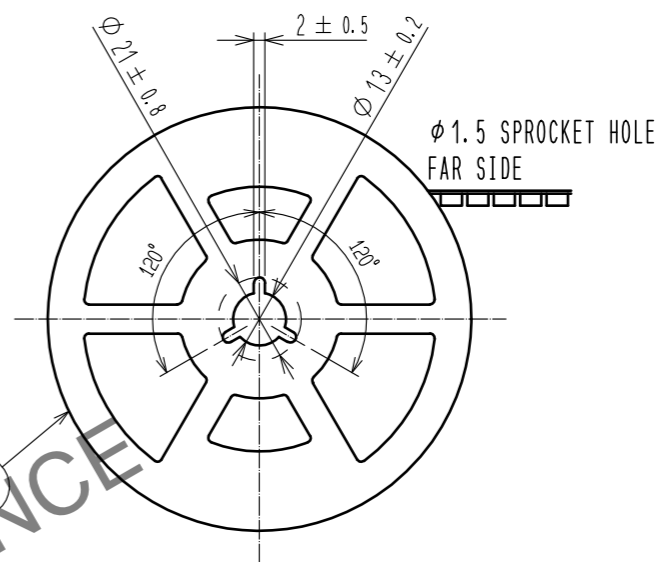
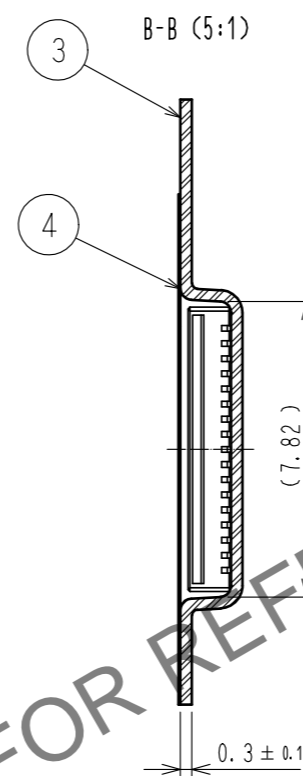
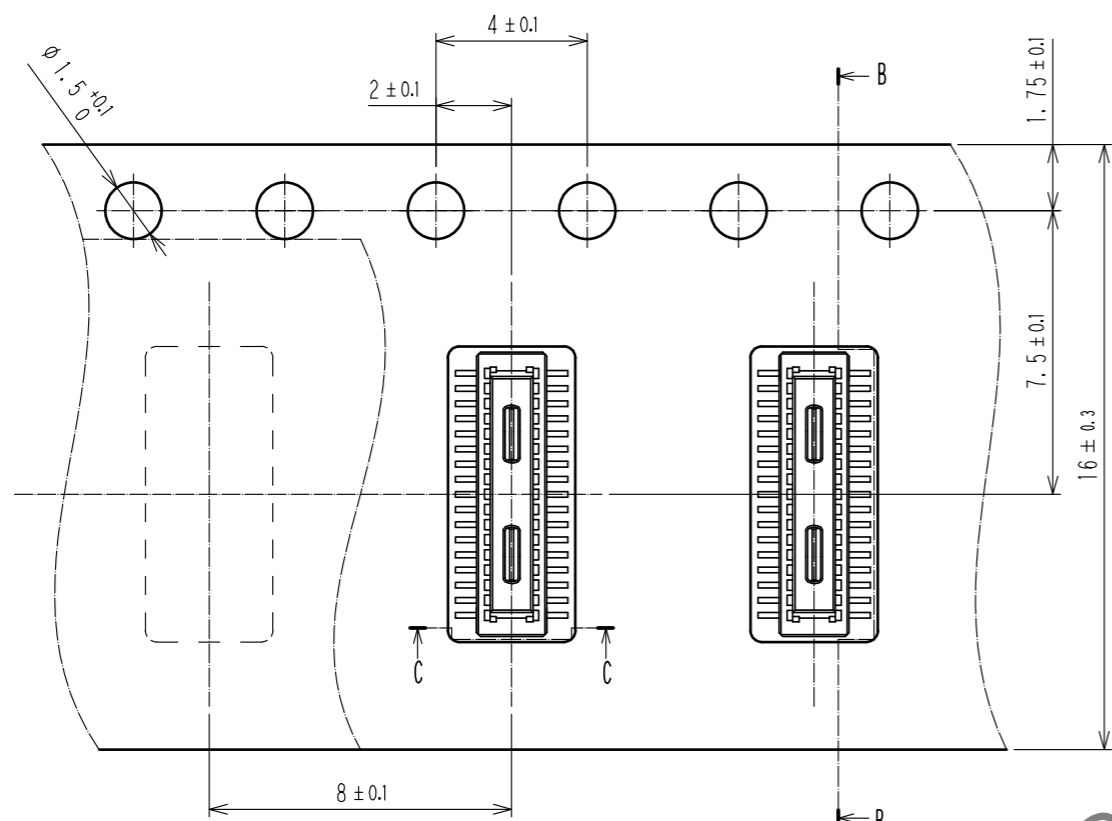

DIRECTION OF UNREELING

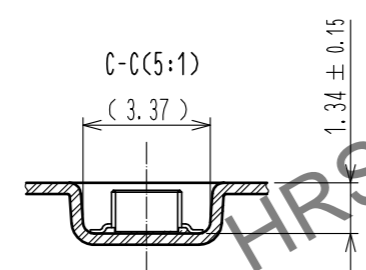

D-D(FREE)

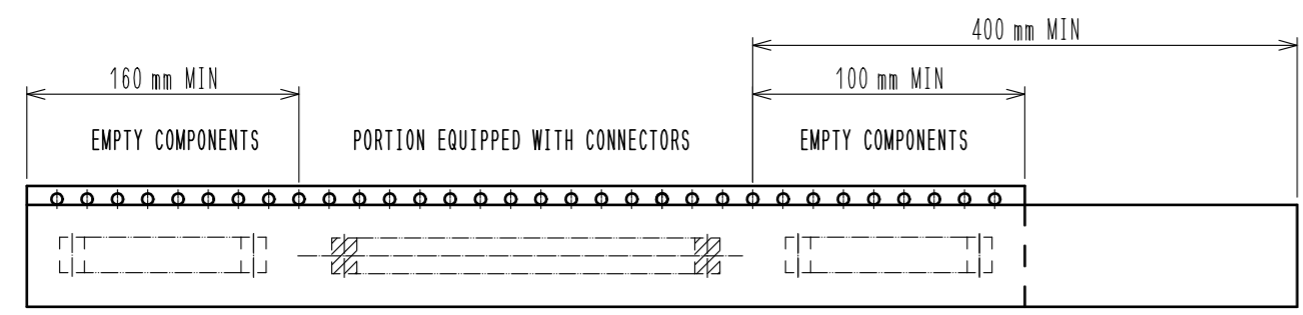
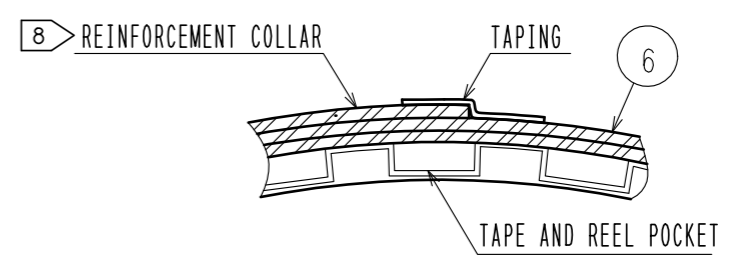

- NOTES
- 5. PER REEL 1000 CONNECTORS.
 - 6. THE DIMENSIONS IN PARENTHESES ARE FOR REFERENCE.
 - 7. REFER TO JIS C 0806, IEC 60286-3 (PACKING OF COMPONENTS FOR AUTOMATIC HANDLING)
 - 8. AFTER PACKAGING, ROLL 2 METERS OF THE REINFORCEMENT COLLAR TO OUTER CIRCUMFERENCE OF TAPE AND REEL POCKET, AND TAPE DOWN AT THE END THE COLLAR.
 - 9. PRODUCT REELS AND PACKAGING WILL BE CLEARLY LABELED WITH THE PART NUMBER, LOT NUMBER AND QUANTITY.

HRS	DRAWING NO.	EDC-311344-58-01
	PART NO.	DF40C-30DP-0.4V(58)
	CODE NO.	CL0684-4012-4-58
		2/3

Apr.1.2026 Copyright 2026 HIROSE ELECTRIC CO., LTD. All Rights Reserved.
In case of consideration for using Automotive equipment / device which demand high reliability, kindly contact our sales window correspondents.

△10. PLEASE REFER TO THE PRODUCT GUIDELINE ETAD-H1015 FOR DETAIL OF CONNECTOR HANDLING.

THE POSITION BETWEEN THE CONNECTOR AND PAD

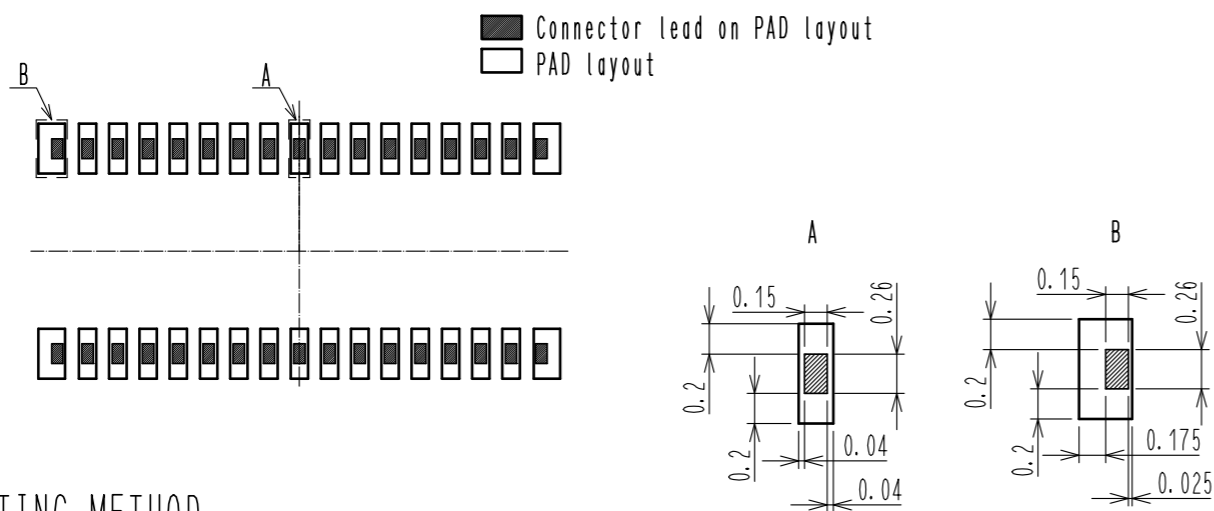

MATING METHOD

PLEASE MATE THE CONNECTOR BY HAND.

MATING PROCEDURE

- (1) FIND THE ALIGNMENT AREA TO THE CONNECTOR IN THE APPROPRIATE MATING POSITION.
 THIS CONNECTOR HAS AN ALIGNMENT CHAMBER(GUIDANCE RIBS) ON RECEPTACLE SIDE AND 'R' ON PLUG SIDE, SO THAT THE CONNECTOR WILL BE SELF-ALIGNED.
 WHEN THE CONNECTOR COMES TO THE APPROPRIATE POSITION, THE CONNECTOR GOES INTO THE ALIGNED POSITION.
 WHEN ALIGNED, IT CAN BE FELT BY HAND.

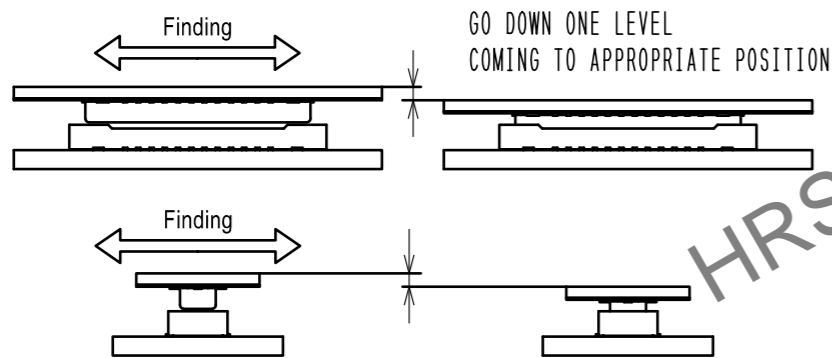

- (2) WHEN GUIDING, THE CONNECTORS ARE ALIGNED PARALLEL TO EACH OTHER, WITH LONGITUDINAL AND LATERAL MOVEMENTS RESTRICTED. MATE THEM PROPERLY BY APPLYING FORCE IN THIS CONDITION.

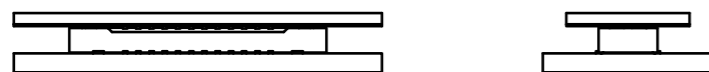

- (3) MAKE SURE THE CONNECTORS ARE MATED CORRECTLY. IF ONE SIDE IS FLOATING OR THE CONNECTORS ARE MATED IN ONE DIRECTION, UN-MATE THEM ONCE, AND THEN MATE THEM AGAIN, FOLLOWING THE PROCEDURES ABOVE FROM THE BEGINNING.

UN-MATING METHOD

PLEASE UN-MATE THE CONNECTOR BY HAND

- (1) UN-MATE THE CONNECTORS PARALLEL TO EACH OTHER. HOWEVER, IF THE CONNECTORS HAVE HIGH PIN COUNTS OR THINNER FPC AND STIFFENER, IT BECOMES MORE DIFFICULT TO DO SO.

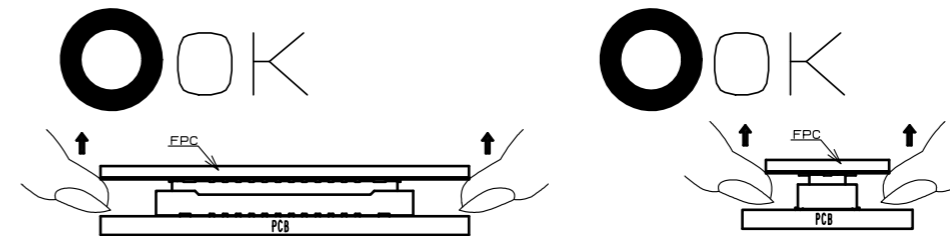

- (2) IF THE CONNECTOR CANNOT BE UN-MATED PARALLEL IT CAN BE REMOVED DIAGONALLY FROM THE PITCH DIRECTION. BE CAREFUL TO DO SO SINCE THIS ACTION APPLIES STRESS ON THE CONTACT.



- (3) IF THE FPC IS NOT RIGID, THE CONNECTOR CAN BE BROKEN. PLEASE CHECK THE ACTION OF THE FPC TO BE USED REPEATEDLY AT THE TIME OF TRIAL PRODUCTION. BE CAREFUL TO UN-MATE THEM FROM THE PITCH DIRECTION, PULLING IT FROM THE CORNER CAN ALSO RISK TO PUTTING STRESS ON CONTACTS.

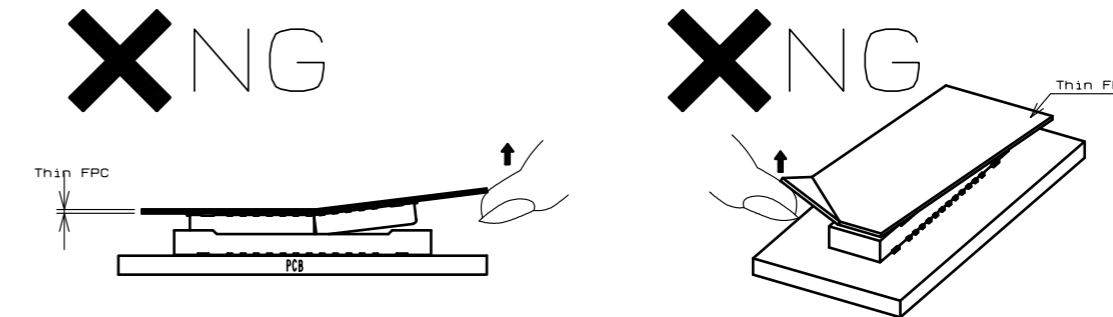

- (4) Caution for using multiple connectors.

Please avoid using more than a single mated pair of connectors between two sandwiched PCBs, like the picture on the below.
 Due to possible misalignment, connector breakage while and after mating may occur.

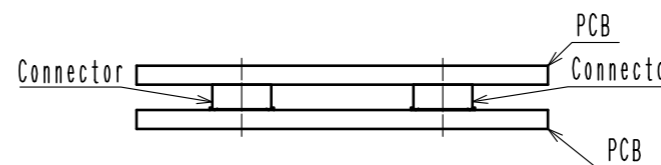

If using more than a single mated pair, please use divided boards for each connection.

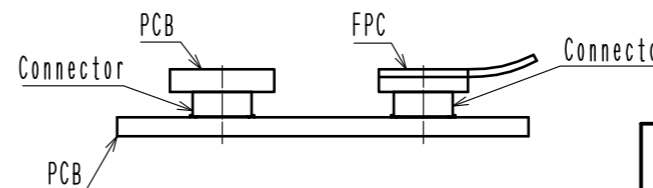

HRS	DRAWING NO.	EDC-311344-58-01
	PART NO.	DF40C-30DP-0.4V(58)
	CODE NO.	CL0684-4012-4-58
		△ 3/3