

Feb.1.2021 Copyright 2021 HIROSE ELECTRIC CO., LTD. All Rights Reserved.
In case of consideration for using Automotive equipment / device which demand high reliability, kindly contact our sales window correspondents.

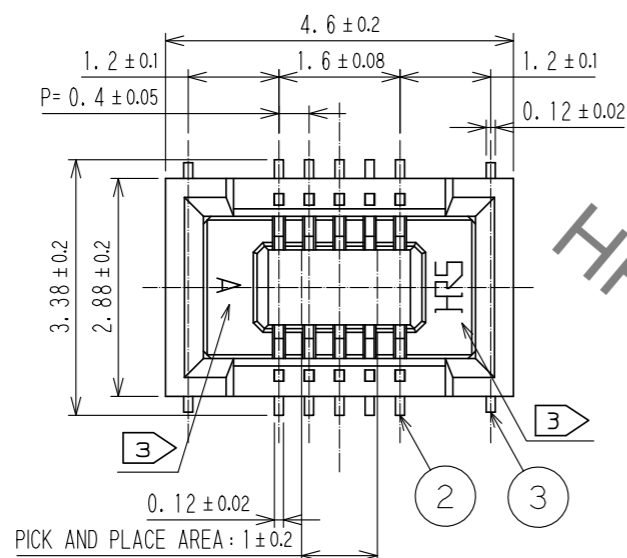

RECOMMENDED PATTERN

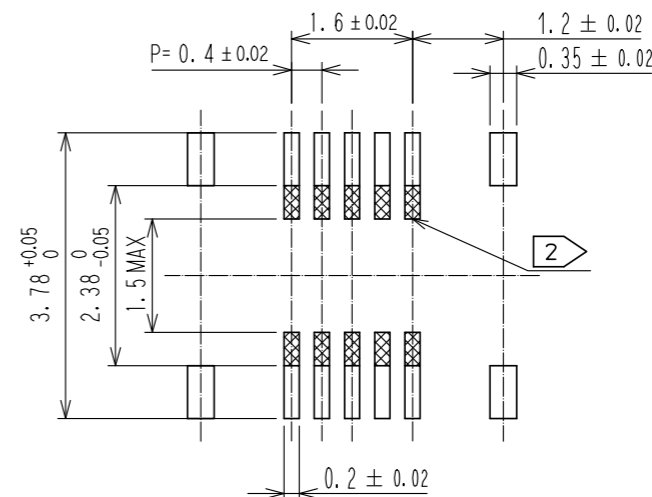

RECOMMENDED METAL MASK THICKNESS: 120 μm
RECOMMENDED MASK OPENING RATIO: 80% FOR LEAD PAD

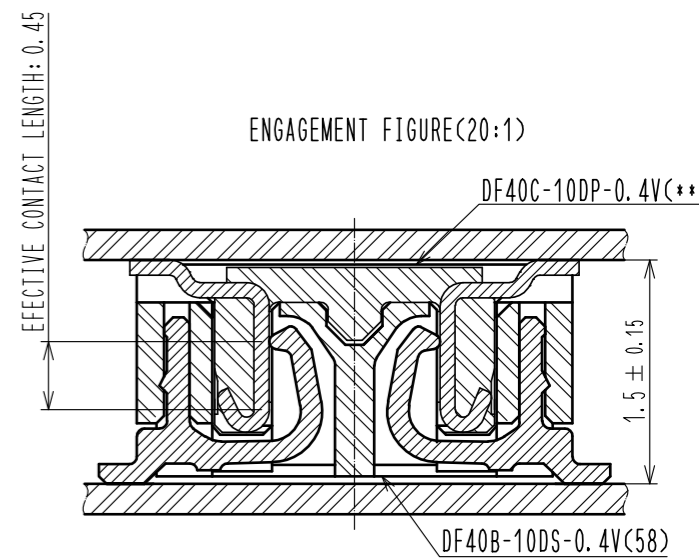
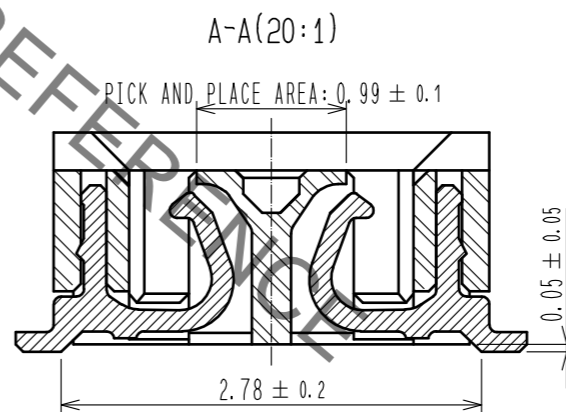
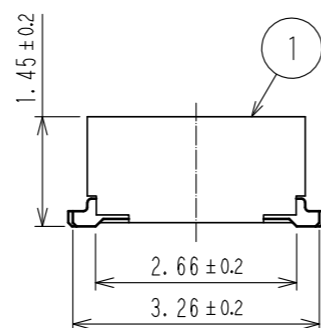
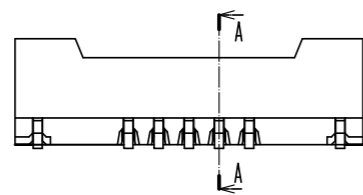

- NOTES) 1. ALL LEADS AND REINFORCED METAL FITTINGS CO-PLANARITY SHALL BE 0.1mm MAX.
 2. IS NO PATTERN AREA OTHER THAN THE SAME CIRCUIT.
 3. HRS MARK AND CAV NO. IS INDICATED IN APPROXIMAL POSITION SHOWN.

NO.	MATERIAL	FINISH	REMARKS	NO.	MATERIAL	FINISH	REMARKS
2	PHOSPHOR BRONZE		CONTACT AREA: GOLD 0.05 μm MIN SMT LEAD: GOLD 0.05 μm MIN UNDERPLATING: NICKEL 1 μm MIN	7	PS		CLEAR, REINFORCEMENT COLLAR
1	LCP		BLACK, UL94V-0	6	PS		BLACK
				5	POLYESTER		CLEAR, COVER TAPE
				4	PS		CLEAR, EMBOSSED CARRIER TAPE
				3	PHOSPHOR BRONZE		GOLD 0.05 μm MIN UNDERPLATING: NICKEL 1 μm MIN

OVER	TO	TOLERANCE	UNITS	SCALE	COUNT	DESCRIPTION OF REVISIONS	DESIGNED	CHECKED	DATE
6	18	±0.3	mm	? : 1	1	APPROVED : WR. FUKUCHI	20190902		
6	18	±0.5	mm	ANGULAR ±1°	1	CHECKED : TS. MIYAZAKI	20190902		
18	50	±0.7	mm		1	DESIGNED : RH. KAGAMI	20190902		
50	125	±1	mm		1	DRAWN : RH. KAGAMI	20190902		

ASSEMBLY DRAWING	DRAWING NO. EDC-314294-58-00
	PART NO. DF40B-10DS-0.4V(58)
	CODE NO. CL684-4038-8-58

Feb.1.2021 Copyright 2021 HIROSE ELECTRIC CO., LTD. All Rights Reserved.
 In case of consideration for using Automotive equipment / device which demand high reliability, kindly contact our sales window correspondents.

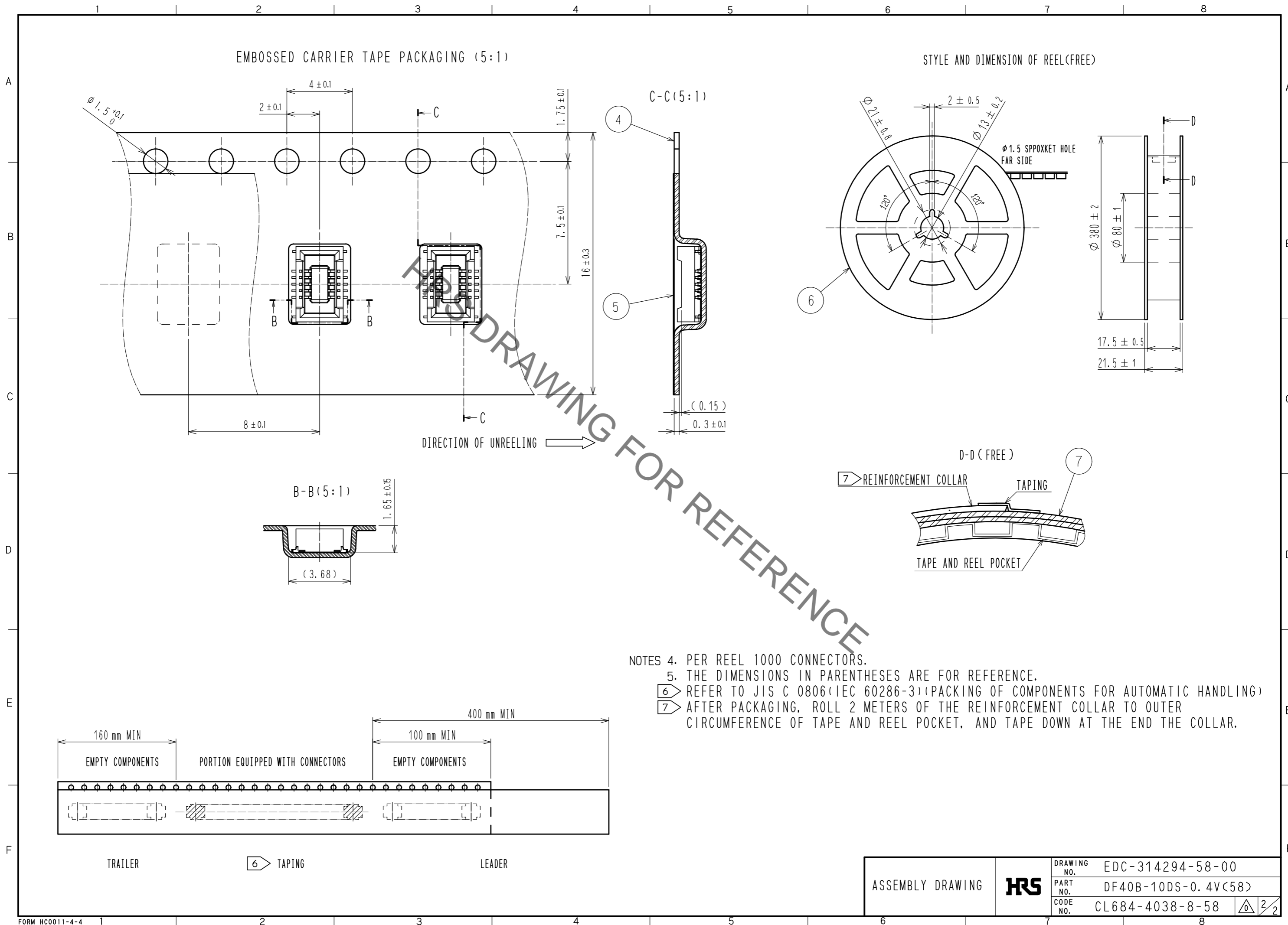

- NOTES
- 4. PER REEL 1000 CONNECTORS.
 - 5. THE DIMENSIONS IN PARENTHESES ARE FOR REFERENCE.
 - 6. REFER TO JIS C 0806 (IEC 60286-3) (PACKING OF COMPONENTS FOR AUTOMATIC HANDLING)
 - 7. AFTER PACKAGING, ROLL 2 METERS OF THE REINFORCEMENT COLLAR TO OUTER CIRCUMFERENCE OF TAPE AND REEL POCKET, AND TAPE DOWN AT THE END THE COLLAR.

ASSEMBLY DRAWING	HRS	DRAWING NO.	EDC-314294-58-00
		PART NO.	DF40B-10DS-0.4V(58)
		CODE NO.	CL684-4038-8-58
			2/2