

Jan.1.2021 Copyright 2021 HIROSE ELECTRIC CO., LTD. All Rights Reserved.
 In case of consideration for using Automotive equipment / device which demand high reliability, kindly contact our sales window correspondents.

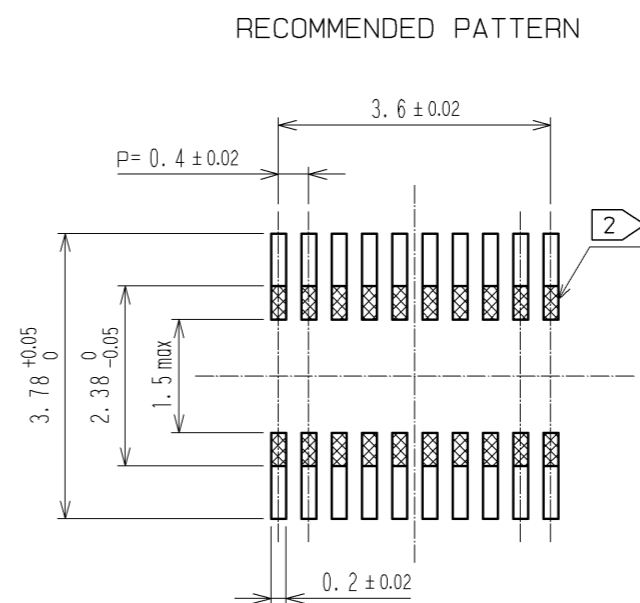

RECOMMENDED METAL MASK THICKNESS : 120μm
 RECOMMENDED METAL MASK OPENING RATIO : 80% FOR LEAD PAD

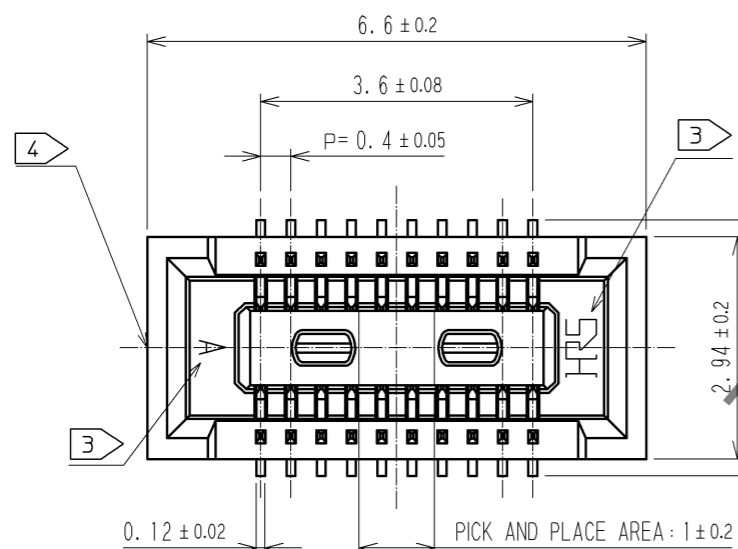
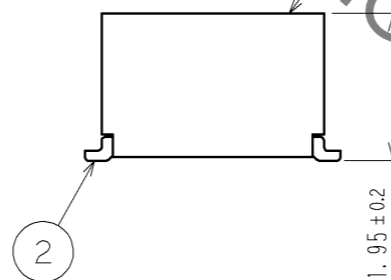
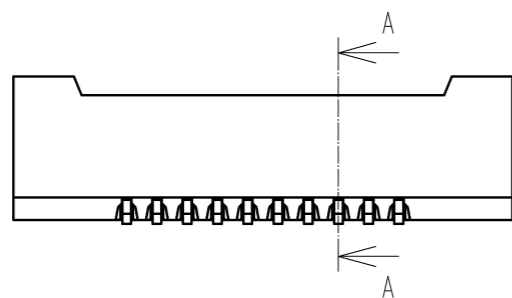

A-A (20:1)

ENGAGEMENT FIGURE (20:1)

PICK AND PLACE AREA: 0.99 ± 0.1

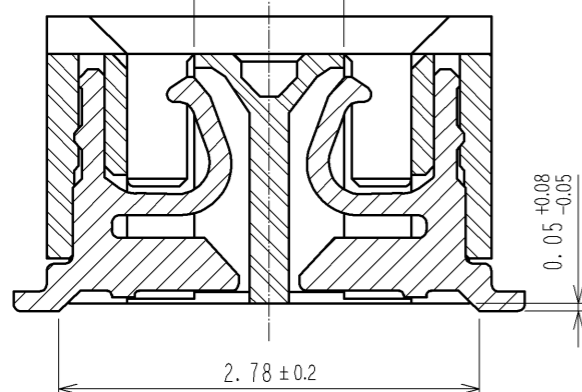

EFFECTIVE CONTACT LENGTH: 0.45

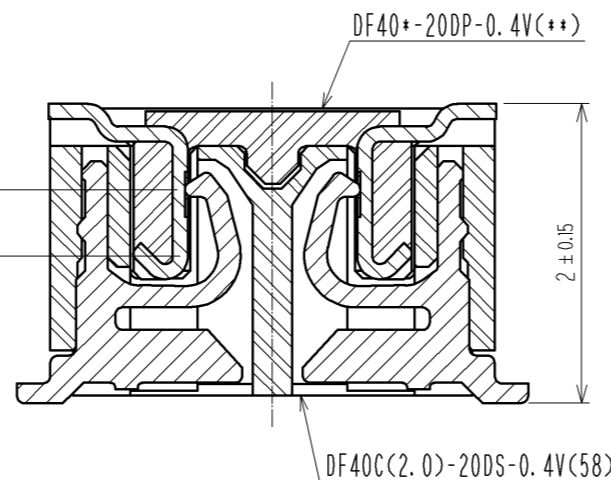

- NOTES
1. ALL LEADS AND REINFORCED METAL FITTINGS CO-PLANARITY SHALL BE 0.1mm MAX.
 2. IS NO PATTERN AREA OTHER THAN THE SAME CIRCUIT.
 3. HRS MARK AND CAV NO. IS INDICATED IN APPROXIMAL POSITION SHOWN.
 4. GATE POSITION IS POSITIONED IN APPROXIMAL AREA SHOWN.

NO.	MATERIAL	FINISH . REMARKS	NO.	MATERIAL	FINISH . REMARKS
2	PHOSPHOR BRONZE	CONTACT AREA: GOLD 0.05μm MIN	6	PS	CLEAR, REINFORCEMENT COLLAR
		SMT LEAD: GOLD 0.05μm MIN	5	PS	BLACK, PLASTIC REEL
		UNDERPLATING: NICKEL 1μm MIN	4	POLYESTER	CLEAR, COVER TAPE
1	LCP	BLACK, UL94V-0	3	PS	CLEAR, EMBOSSED CARRIER TAPE

UNITS	SCALE	COUNT	DESCRIPTION OF REVISIONS	DESIGNED	CHECKED	DATE
mm	10:1	△	APPROVED : KH. IKEDA 14.06.17			
			CHECKED : TS. MIYAZAKI 14.06.17			
			DESIGNED : RT. SHIMIZU 14.06.17			
			DRAWN : KR. AJITO 14.06.17			

DRAWING NO.	PART NO.	CODE NO.
EDC3-314723-02	DF40C(2.0)-20DS-0.4V(58)	CL684-4040-0-58

Jan.1.2021 Copyright 2021 HIROSE ELECTRIC CO., LTD. All Rights Reserved.
In case of consideration for using Automotive equipment / device which demand high reliability, kindly contact our sales window correspondents.

EMBOSSED CARRIER TAPE DIMENSIONS (5:1)

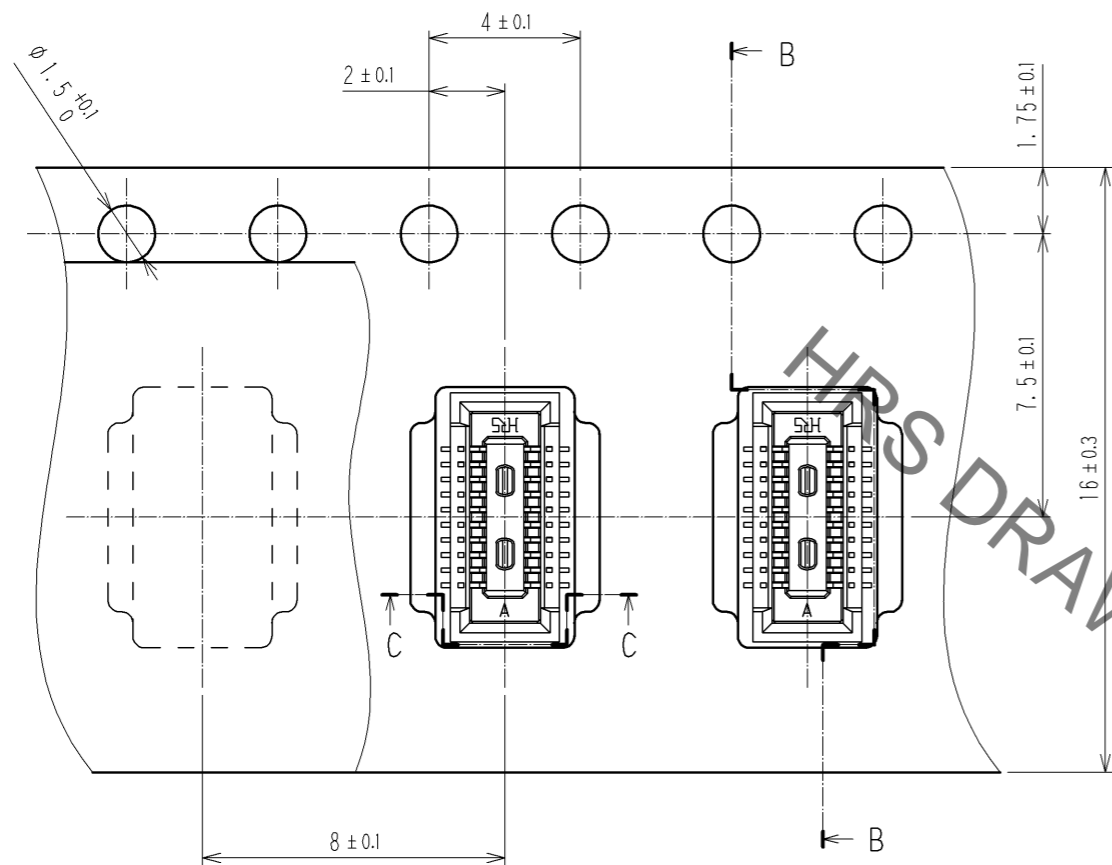

DIRECTION OF UNREELING →

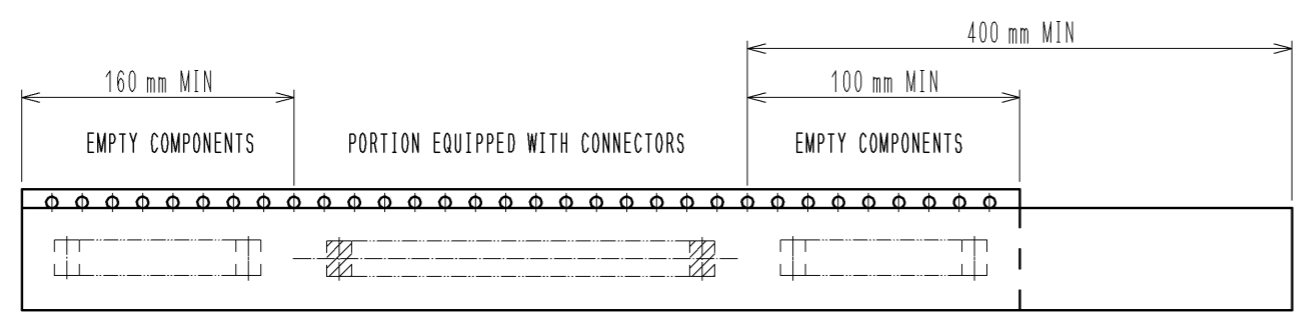
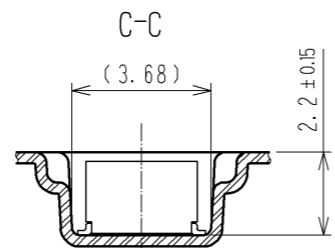

TRAILER 7 TAPING LEADER

STYLE AND DIMENSION OF REEL(FREE)

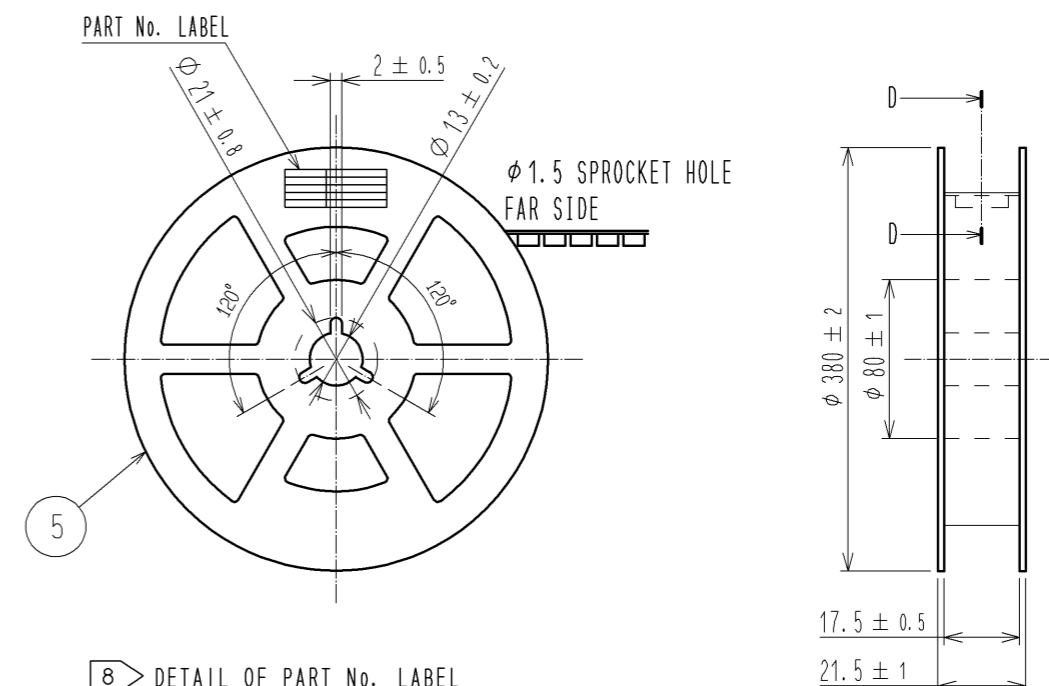

8 DETAIL OF PART No. LABEL

製造年月日	** ** *
製品コード	CL684-4040-0-58
製品名	DF40C(2.0)-20DS-0.4V(58)
数量	1000
納入者	ヒロセ電機(株)

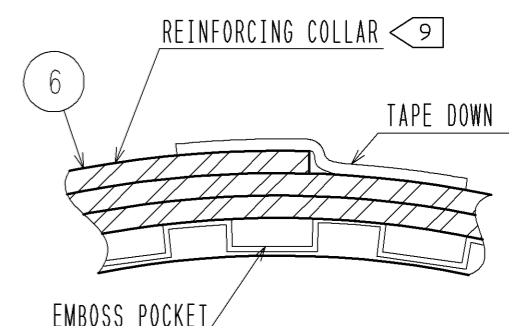

- NOTES
- 5. PER REEL 1000 CONNECTORS.
 - 6. THE DIMENSIONS IN PARENTHESES ARE FOR REFERENCE.
 - 7 REFER TO JIS C 0806(IEC 60286-3)
(PACKING OF COMPONENTS FOR AUTOMATIC HANDLING)
 - 8 DETAIL OF PART No. LABEL IS WRITTEN IN JAPANESE.
PART NO. LABEL DESCRIBES THE FOLLOWING INFORMATION FROM TOP.
PRODUCTION DATE:
PRODUCT CODE: CL684-4040-0-58
PART NUMBER: DF40C(2.0)-20DS-0.4V(58)
NUMBER OF PIECES: 1000 PIECES
SUPPLIER NAME: HIROSE ELECTRIC CO., LTD.
 - 9 AFTER PACKING. WRAP AROUND THE REELED POCKET WITH 2m LENGTH REINFORCING COLLAR AND TAPE DOWN AT THE END.

HRS	DRAWING NO.	EDC3-314723-02
	PART NO.	DF40C(2.0)-20DS-0.4V(58)
	CODE NO.	CL684-4040-0-58
		△ 2/2