

Oct.1.2021 Copyright 2021 HIROSE ELECTRIC CO., LTD. All Rights Reserved.
In case of consideration for using Automotive equipment / device which demand high reliability, kindly contact our sales window correspondents.

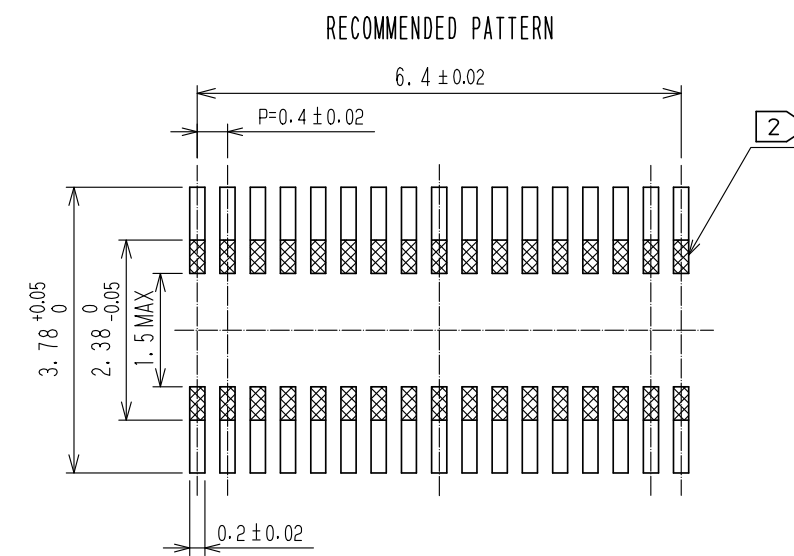

RECOMMENDED METAL MASK THICKNESS: 120 μm
RECOMMENDED MASK OPENING RATIO: 80% FOR LEAD PAD

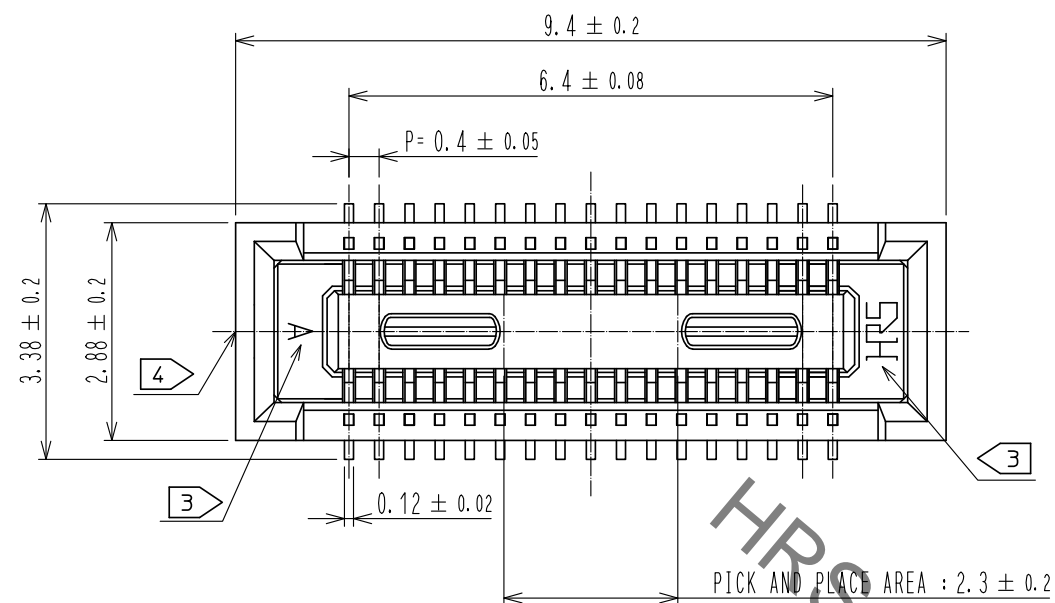
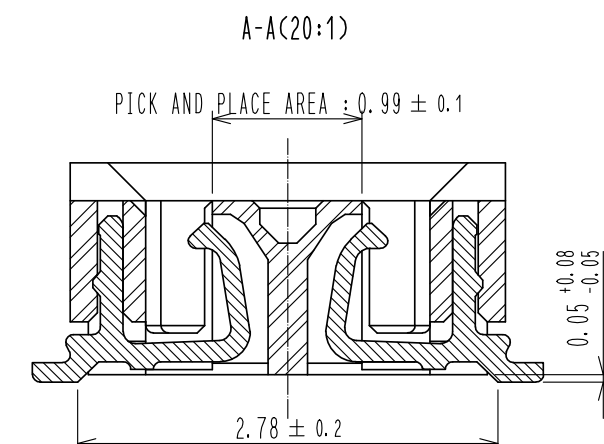
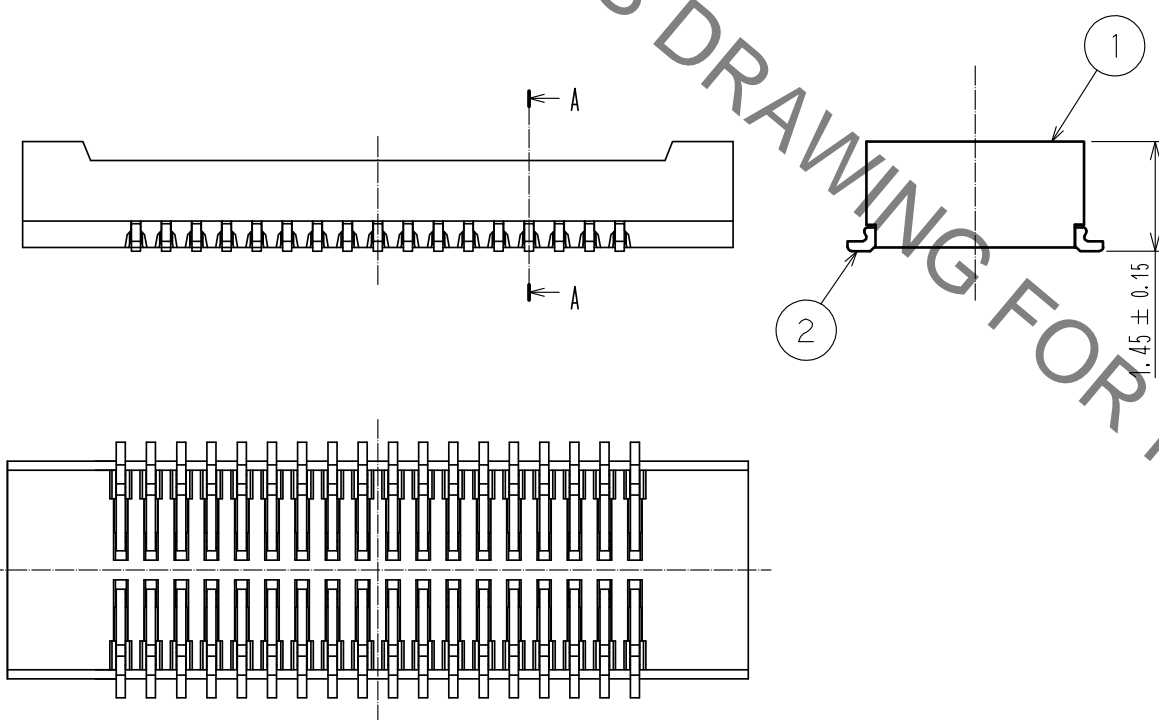

ENGAGEMENT FIGURE (20:1)

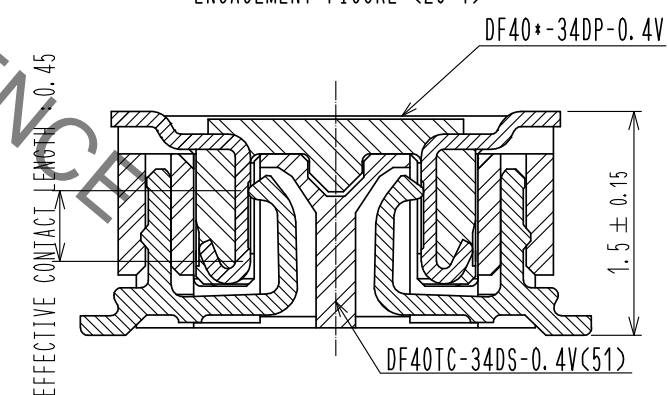

- NOTES) 1. ALL LEADS METAL FITTINGS CO-PLANARITY SHALL BE 0.1mm MAX.
 2. IS NO PATTERN AREA OTHER THAN THE SAME CIRCUIT.
 3. HRS MARK AND CAV NO. ARE INDICATED IN APPROXIMAL POSITION SHOWN.
 4. GATE IS COATED IN APPROXIMAL AREA.

2	COPPER ALLOY	CONTACT AREA: GOLD 0.05 μm MIN SMT LEAD: GOLD 0.05 μm MIN UNDERPLATING: NICKEL 1 μm MIN	6	PS	CLEAR, REINFORCEMENT COLLAR		
			5	PS	BLACK, PLASTIC REEL		
			4	POLYESTER	CLEAR, COVER TAPE		
1	LCP	BLACK, UL94V-0	3	PS	CLEAR, EMBOSSED CARRIER TAPE		
NO.	MATERIAL	FINISH, REMARKS	NO.	MATERIAL	FINISH, REMARKS		
UNITS		SCALE	COUNT	DESCRIPTION OF REVISIONS	DESIGNED	CHECKED	DATE
mm		10 : 1					
APPROVED : WR. FUKUCHI			18.04.23	DRAWING NO. EDC-381216-51-00			
CHECKED : TS. MIYAZAKI			18.04.23	PART NO. DF40TC-34DS-0.4V(51)			
DESIGNED : SJ. WADA			18.04.23	CODE NO. CL684-4240-0-51			
DRAWN : SN. NUMAZAKI			18.04.20	1/2			

Oct.1.2021 Copyright 2021 HIROSE ELECTRIC CO., LTD. All Rights Reserved.
 In case of consideration for using Automotive equipment / device which demand high reliability, kindly contact our sales window correspondents.

EMBOSED CARRIER TAPE PACKAGING (5:1)

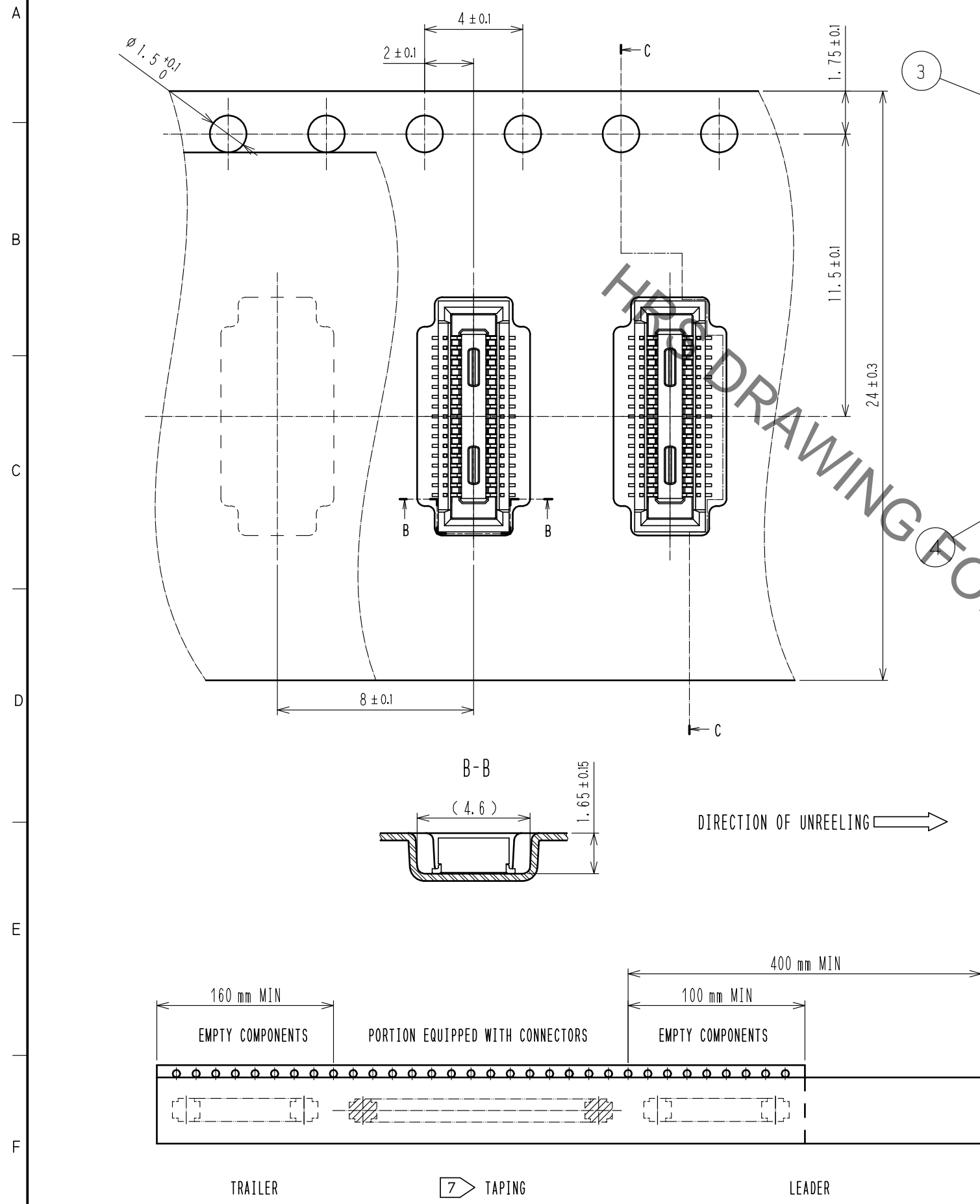

STYLE AND DIMENSION OF REEL(FREE)

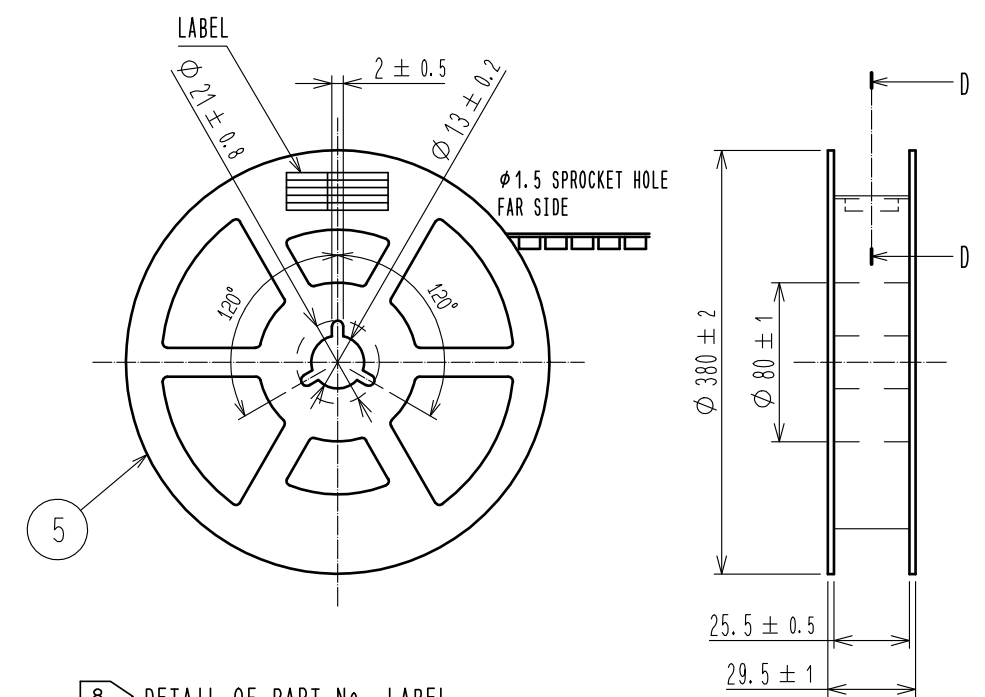

8 > DETAIL OF PART No. LABEL

製造年月日	** ** *
製品コード	CL684-4240-0-51
製品名	DF40TC-34DS-0.4V(51)
数量	5000
納入者	ヒロセ電機(株)

D-D(FREE)

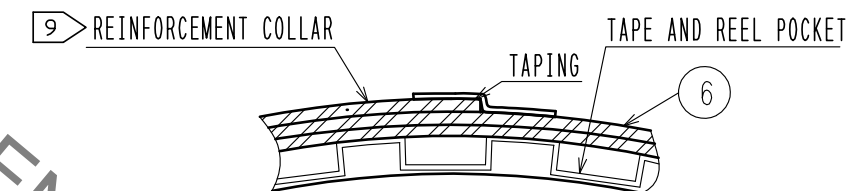

- NOTES
5. PER REEL 5000 CONNECTORS.
 6. THE DIMENSIONS IN PARENTHESES ARE FOR REFERENCE.
 - 7 > REFER TO JIS C 0806, IEC 60286-3 (PACKING OF COMPONENTS FOR AUTOMATIC HANDLING)
 - 8 > DETAIL OF PART No. LABEL IS WRITTEN IN JAPANESE. PART No. LABEL DESCRIBES THE FOLLOWING INFORMATION FROM TOP.
 PRODUCTION DATE:
 PRODUCT CODE: CL684-4240-0-51
 PART NUMBER: DF40TC-34DS-0.4V(51)
 NUMBER OF PIECES: 5000 PIECES
 SUPPLIER NAME: HIROSE ELECTRIC CO., LTD.
 - 9 > AFTER PACKAGING, ROLL 2 METERS OF THE REINFORCEMENT COLLAR TO OUTER CIRCUMFERENCE OF TAPE AND REEL POCKET. AND TAPE DOWN AT THE END THE COLLAR.

HRS	DRAWING NO.	EDC-381216-51-00
	PART NO.	DF40TC-34DS-0.4V(51)
	CODE NO.	CL684-4240-0-51
		2/2