

May.1.2021 Copyright 2021 HIROSE ELECTRIC CO., LTD. All Rights Reserved.
In case of consideration for using Automotive equipment / device which demand high reliability, kindly contact our sales window correspondents.

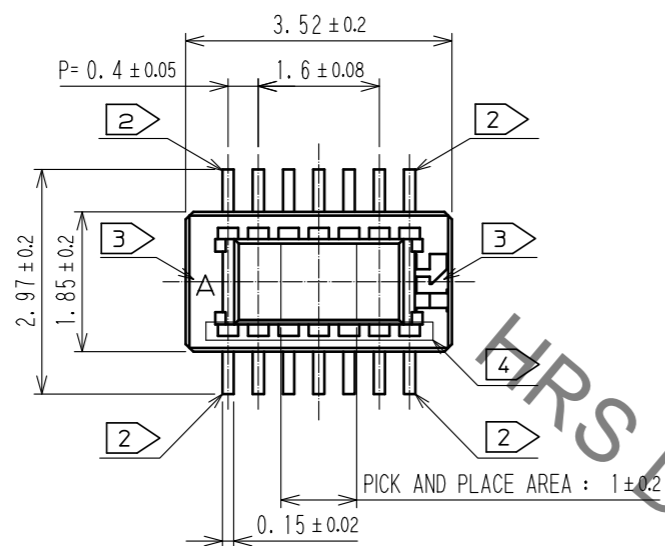

RECOMMENDED PATTERN

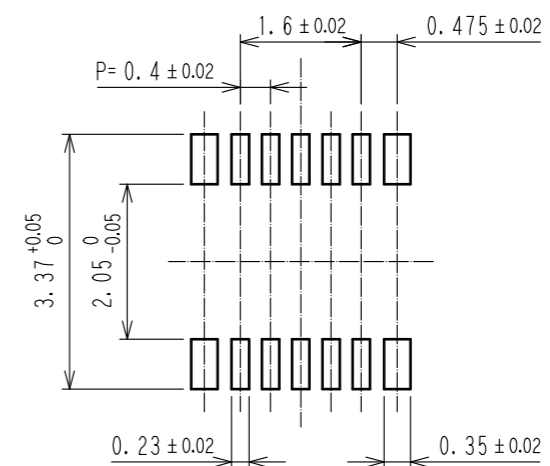

RECOMMENDED METAL MASK THICKNESS: 120μm
RECOMMENDED METAL MASK OPENING RATIO: 80% FOR LEAD PAD

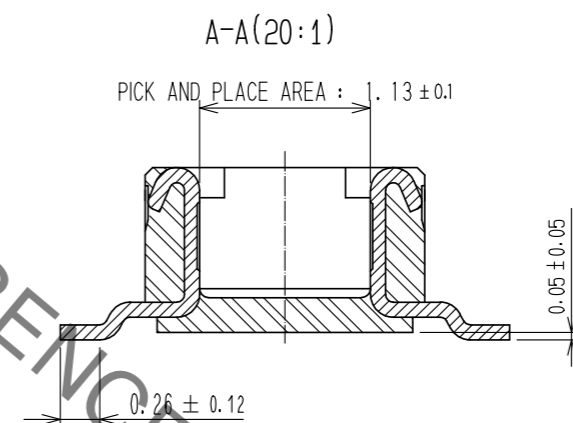
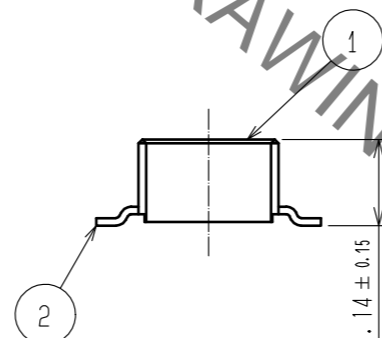
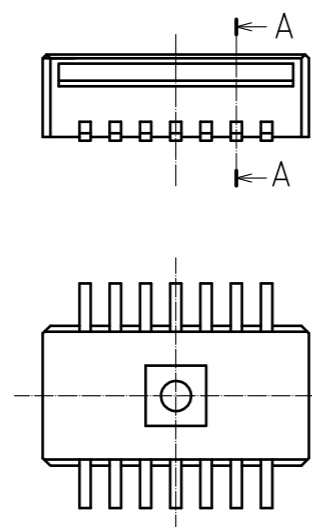

- NOTES
- 1. ALL LEADS CO-PLANARITY SHALL BE USED 0.1MAX.
 - 2. EACH ONE CONTACT AT 4 CORNERS SHALL BE USED AS METAL HOLD DOWN.
 - 3. HRS MARK AND CAV NO. ARE INDICATED IN APPROX. POSITION SHOWN.
 - 4. THERE IS A POSSIBILITY THAT THE RESIN WILL BE EXPOSED AT THIS AREA. BUT THIS WILL NOT AFFECT THE CONTACT RELIABILITY.

NO.	MATERIAL	FINISH . REMARKS	NO.	MATERIAL	FINISH . REMARKS
2	COPPER ALLOY	GOLD 0.05μm MIN UNDERPLATING-NICKEL 1μm MIN	6	PS	CLEAR-REINFORCEMENT COLLAR
1	LCP	UL94V-0-BLACK	5	PS	BLACK-PLASTIC REEL
			4	POLYESTER	CLEAR-COVER TAPE
			3	PS	CLEAR(EMBOSSED CARRIER TAPE)
UNITS	SCALE	COUNT	DESCRIPTION OF REVISIONS		
mm	10 : 1	1	DIS-H-00005725		
DESIGNED		CHECKED		DATE	
YK. SATAKE		TS. MIYAZAKI		20200204	
APPROVED : WR. FUKUCHI 20191122			DRAWING NO. EDC-386793-51-01		
CHECKED : TS. MIYAZAKI 20191122			PART NO. DF40TC-10DP-0.4V(51)		
DESIGNED : YK. SATAKE 20191122			CODE NO. CL684-4269-0-51		
DRAWN : YK. SATAKE 20191122			1/2		

May.1.2021 Copyright 2021 HIROSE ELECTRIC CO., LTD. All Rights Reserved.
 In case of consideration for using Automotive equipment / device which demand high reliability, kindly contact our sales window correspondents.

ENBOSSED CARRIER TAPE PACKAGING (5:1)

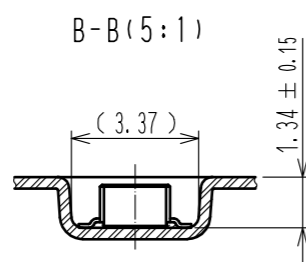
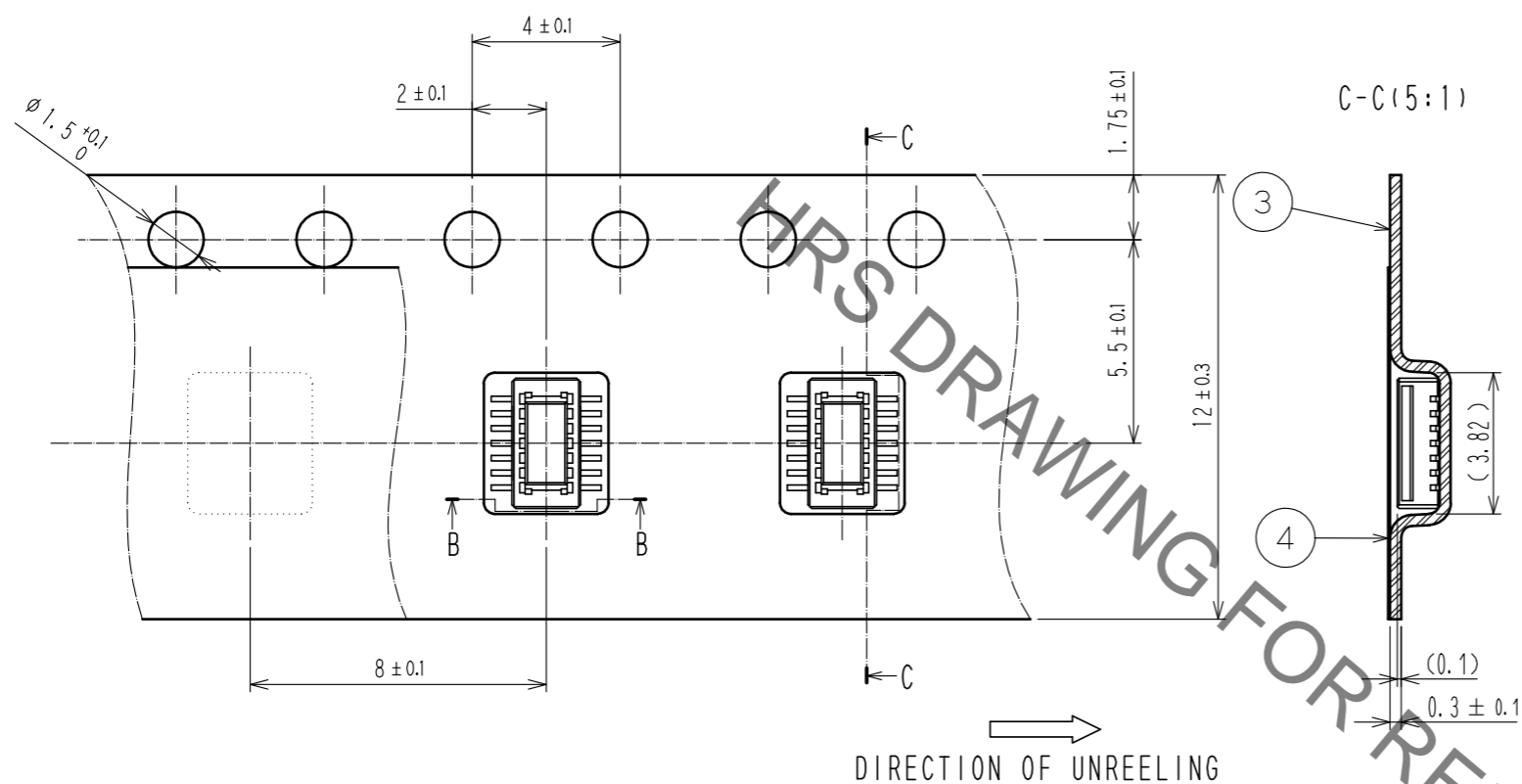

STYLE AND DIMENSIONS OF REEL (FREE)

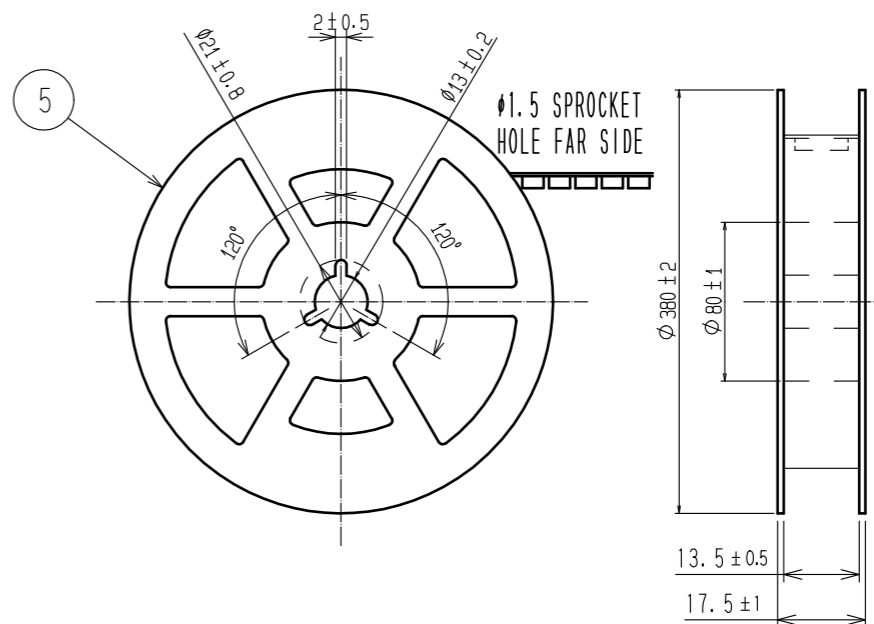

- NOTES
- 5. PER REEL 5000 CONNECTORS.
 - 6. THE DIMENSIONS IN PARENTHESES ARE FOR REFERENCE.
 - 7. REFER TO JIS C 0806 (PACKING OF COMPONENTS FOR AUTOMATIC HANDLING)
 - 8. AFTER PACKAGING, ROLL 2 METERS OF THE REINFORCEMENT COLLAR TO OUTER CIRCUMFERENCE OF TAPE AND REEL POCKET, AND TAPE DOWN AT THE END THE COLLAR.

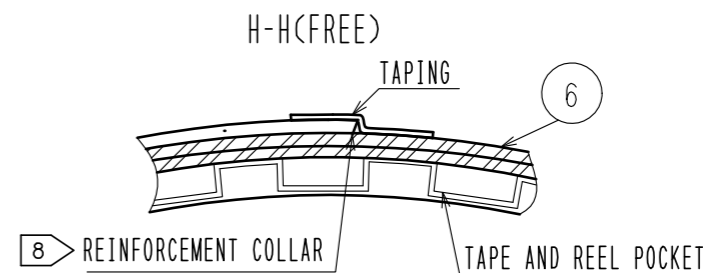
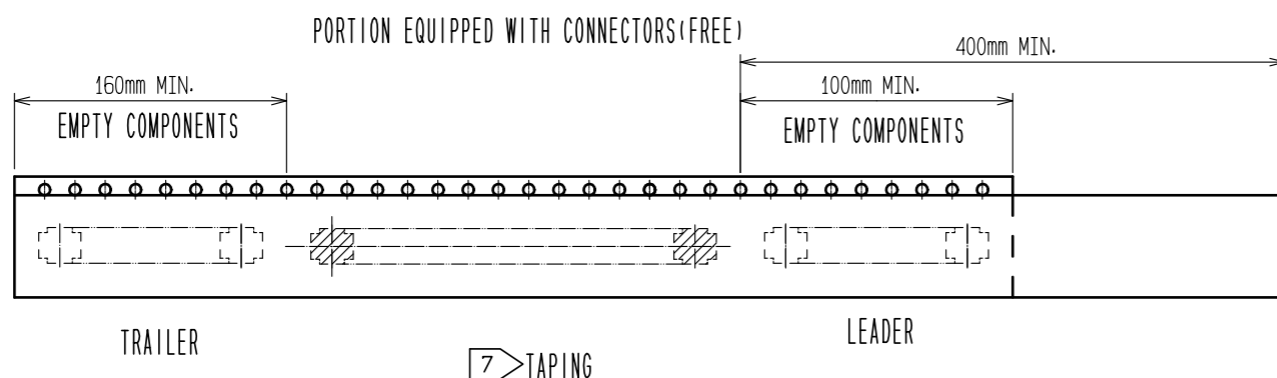

HRS	DRAWING NO.	EDC-386793-51-01
	PART NO.	DF40TC-10DP-0.4V(51)
	CODE NO.	CL684-4269-0-51
		2/2