

Nov.1.2024 Copyright 2024 HIROSE ELECTRIC CO., LTD. All Rights Reserved.
In case of consideration for using Automotive equipment / device which demand high reliability, kindly contact our sales window correspondents.

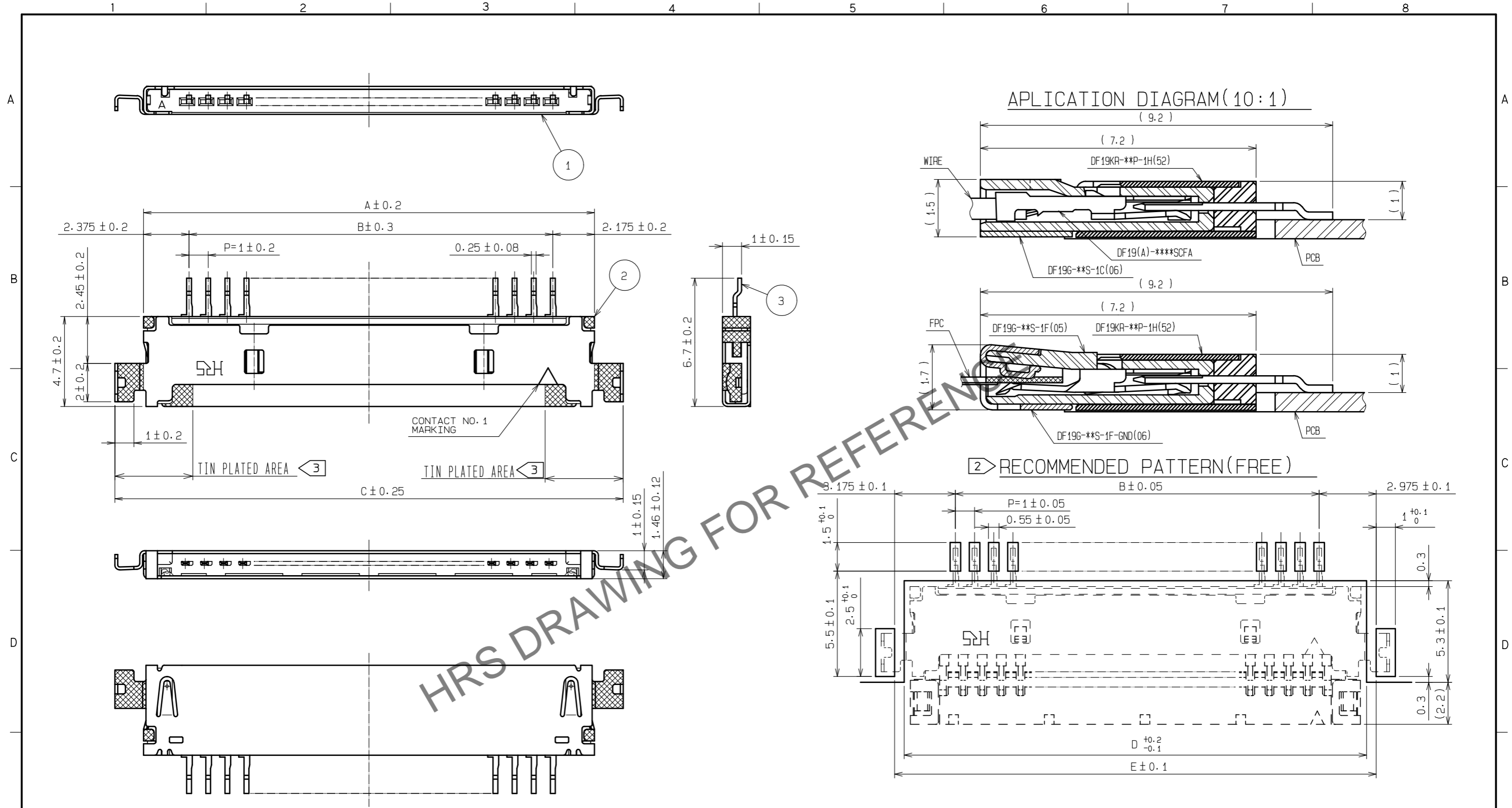

HRS DRAWING FOR REFERENCE

PART No.	CODE No.	NUMBER OF CONTACT	A	B	C	D	E
DF19KR-14P-1H(52)	CL685-0024-8-52	14	17.55	13	20.55	18.15	19.15
DF19KR-20P-1H(52)	CL685-0023-5-52	20	23.55	19	26.55	24.15	25.15

NOTES1: LEAD CO-PLANARITY SHALL BE 0.1 mm MAX.
 2) RECOMMENDED THICKNESS OF CREAM SOLDER PASTE: 0.15mm
 OPEN AREA RATIO: 100%

NO.	MATERIAL	FINISH, REMARKS	NO.	MATERIAL	FINISH, REMARKS
2	PHOSPHER BRONZE	LEAD AREA:TIN PLATED 1#m min UNDER PLATING:NICKEL PLATED 0.5#m min	3	PHOSPHER BRONZE	LEAD AREA:TIN PLATED 1#m min UNDER PLATING:NICKEL PLATED 1#m min
1	POLYAMIDE	BLACK, UL94V-0	4	PS	CLEAR, (EMBOSSD CARRIER TAPE)
			5	POLYESTER	CLEAR, (COVER TAPE)

UNITS	SCALE	COUNT	DESCRIPTION OF REVISIONS	DESIGNED	CHECKED	DATE
mm	5 : 1	1	APPROVED : HS. OKAWA 20200313			
			CHECKED : TS. KUMAZAWA 20200313			
			DESIGNED : HK. HAYASHI 20200313			
			DRAWN : DS. HIROWATARI 20200306			

DRAWING NO.	PART NO.	CODE NO.
EDC-302811-52-00	DF19KR-**P-1H(52)	CL685-

Nov.1.2024 Copyright 2024 HIROSE ELECTRIC CO., LTD. All Rights Reserved.
In case of consideration for using Automotive equipment / device which demand high reliability, kindly contact our sales window correspondents.

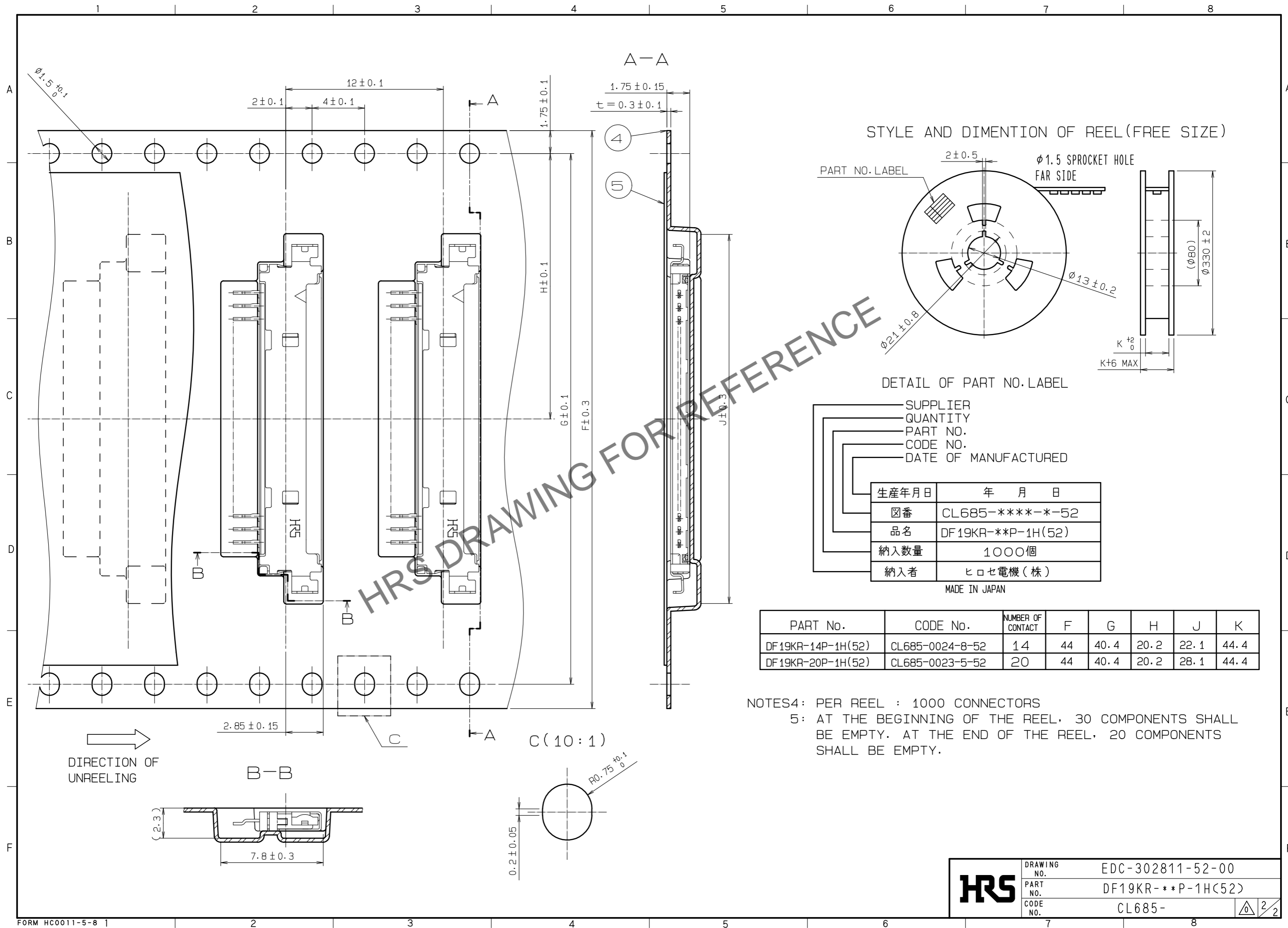

STYLE AND DIMENTION OF REEL (FREE SIZE)

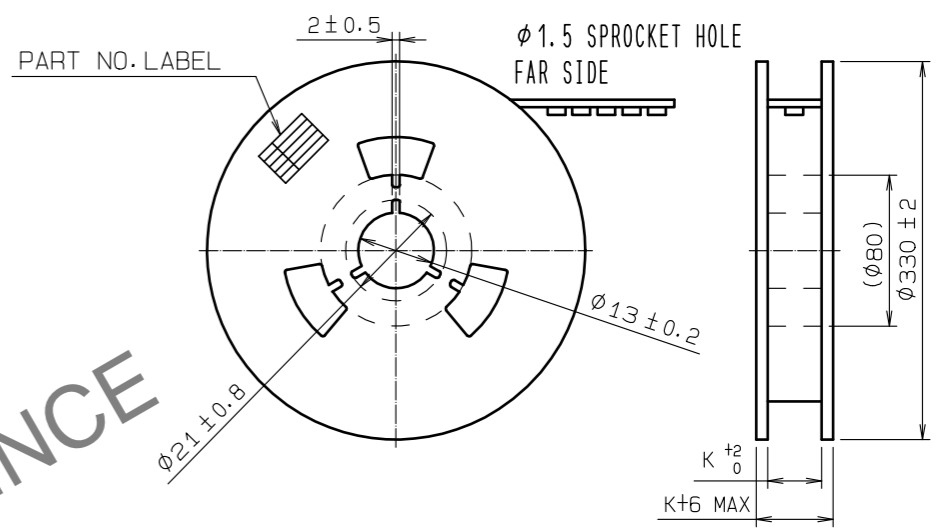

DETAIL OF PART NO. LABEL

SUPPLIER
QUANTITY
PART NO.
CODE NO.
DATE OF MANUFACTURED

生産年月日	年 月 日
図番	CL685-****-*-52
品名	DF19KR-**P-1H(52)
納入数量	1000個
納入者	ヒロセ電機(株)

MADE IN JAPAN

PART No.	CODE No.	NUMBER OF CONTACT	F	G	H	J	K
DF19KR-14P-1H(52)	CL685-0024-8-52	14	44	40.4	20.2	22.1	44.4
DF19KR-20P-1H(52)	CL685-0023-5-52	20	44	40.4	20.2	28.1	44.4

NOTES4: PER REEL : 1000 CONNECTORS
5: AT THE BEGINNING OF THE REEL, 30 COMPONENTS SHALL BE EMPTY. AT THE END OF THE REEL, 20 COMPONENTS SHALL BE EMPTY.

HRS	DRAWING NO.	EDC-302811-52-00
	PART NO.	DF19KR-**P-1H(52)
	CODE NO.	CL685-