

ELV, RoHS COMPLIANT

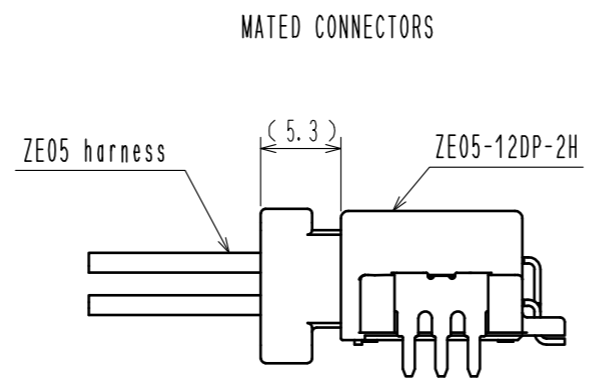

RECOMMENDED PCB PATTERN

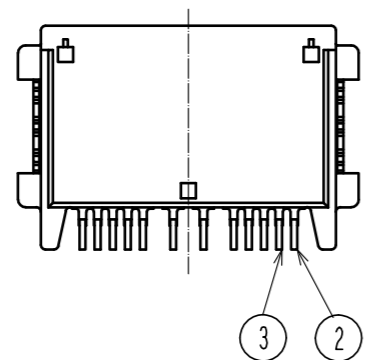
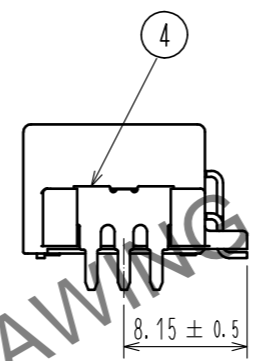
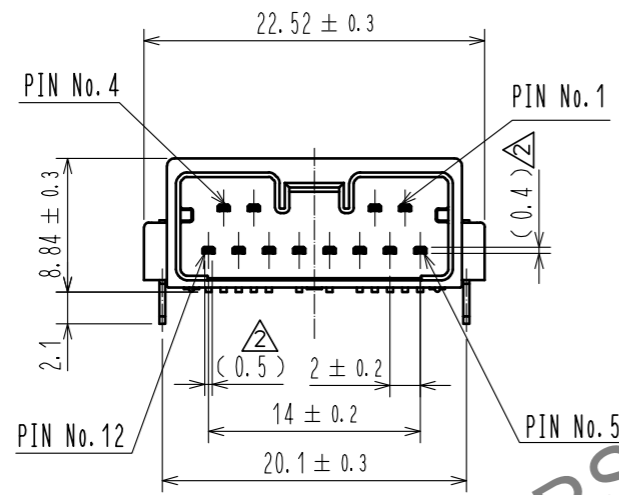
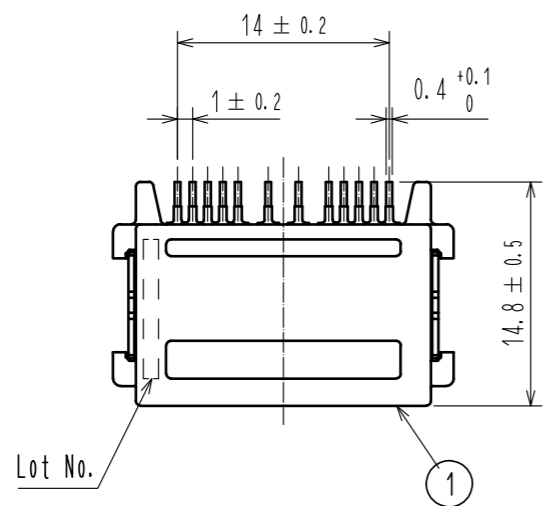
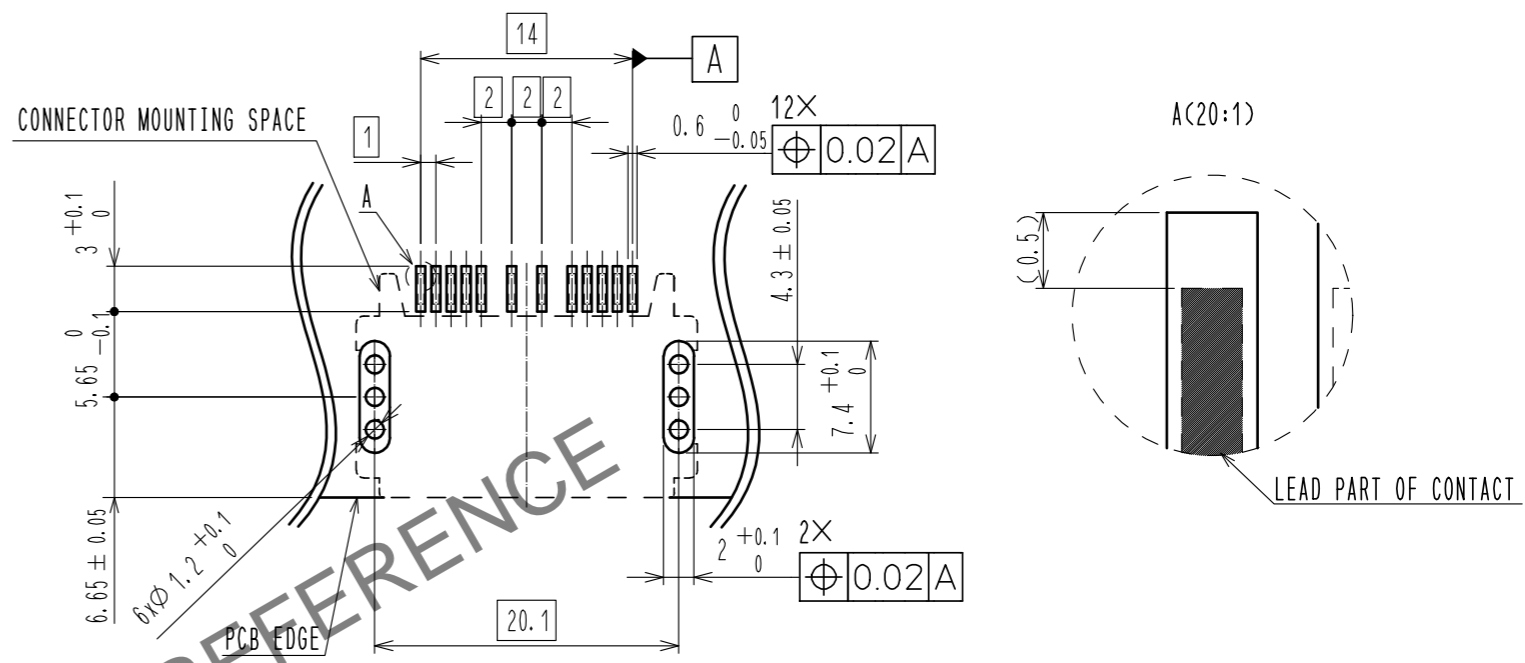

- NOTE 1. RECOMMENDED TEMPERATURE PROFILE FOR REFLOW (REFER TO RIGHT FIG.) USED REFLOW SYSTEM
- : IR IN THE AIR OR NITROGEN
  - NO. OF CYCLES : 2 MAX
  - PEAK : 250°C
  - OVER 230°C : 20~40s
  - PREHEAT : 150~180°C 90~120s
2. TEMPERATURE FOR SOLDERING IRON : 280~300°C WITHIN 2s
3. CO-PLANARITY SHALL BE 0.1mm MAX.
4. RECOMMENDED PCB THICKNESS IS 1.6mm.
5. RECOMMENDED SOLDER THICKNESS IS 0.15mm.

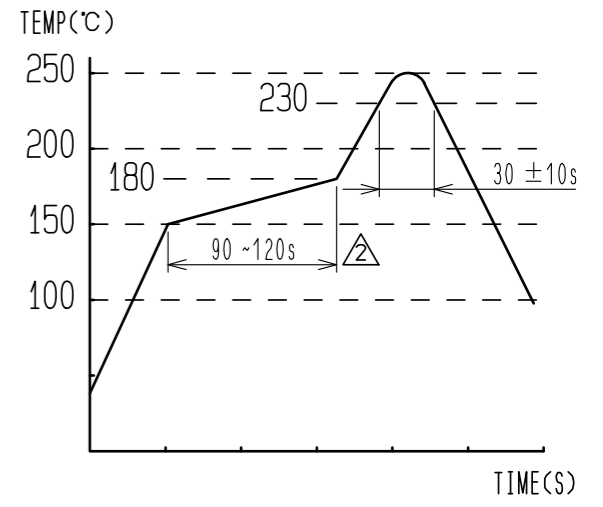

3	BRASS	SURFACE PLATING : TIN PLATING 1μm min					
		UNDER PLATING : NICKEL 1μm min	6	POLYESTER			
2	BRASS	SURFACE PLATING : TIN PLATING 1μm min	5	POLYSTYRENE			
		UNDER PLATING : NICKEL 1μm min			SURFACE PLATING : TIN PLATING 1μm min		
1	PA	BLACK UL94V-0	4	BRASS	UNDER PLATING : NICKEL 1μm min		
NO.	MATERIAL	FINISH . REMARKS	NO.	MATERIAL	FINISH . REMARKS		
UNITS	mm	SCALE	COUNT	DESCRIPTION OF REVISIONS	DESIGNED	CHECKED	DATE
		2 : 1	6	DIS-T-00003979	YONGMUN LEE	HH. TSUKUMO	20181119
APPROVED : HK. UMEHARA		20170912	DRAWING NO.		EDC-368630-00-00		
CHECKED : HK. UMEHARA		20170912	PART NO.		ZE05-12DP-2H		
DESIGNED : AH. EDASHIGE		20170911	CODE NO.		CL752-2104-0-00		
DRAWN : MN. SATOH		20170911					

Jul.1.2024 Copyright 2024 HIROSE ELECTRIC CO., LTD. All Rights Reserved. In case of consideration for using Automotive equipment / device which demand high reliability, kindly contact our sales window correspondents.

Jul.1.2024 Copyright 2024 HIROSE ELECTRIC CO., LTD. All Rights Reserved.  
 In case of consideration for using Automotive equipment / device which demand high reliability, kindly contact our sales window correspondents.

# PACKING STYLE

## PACKING STYLE DRAWING

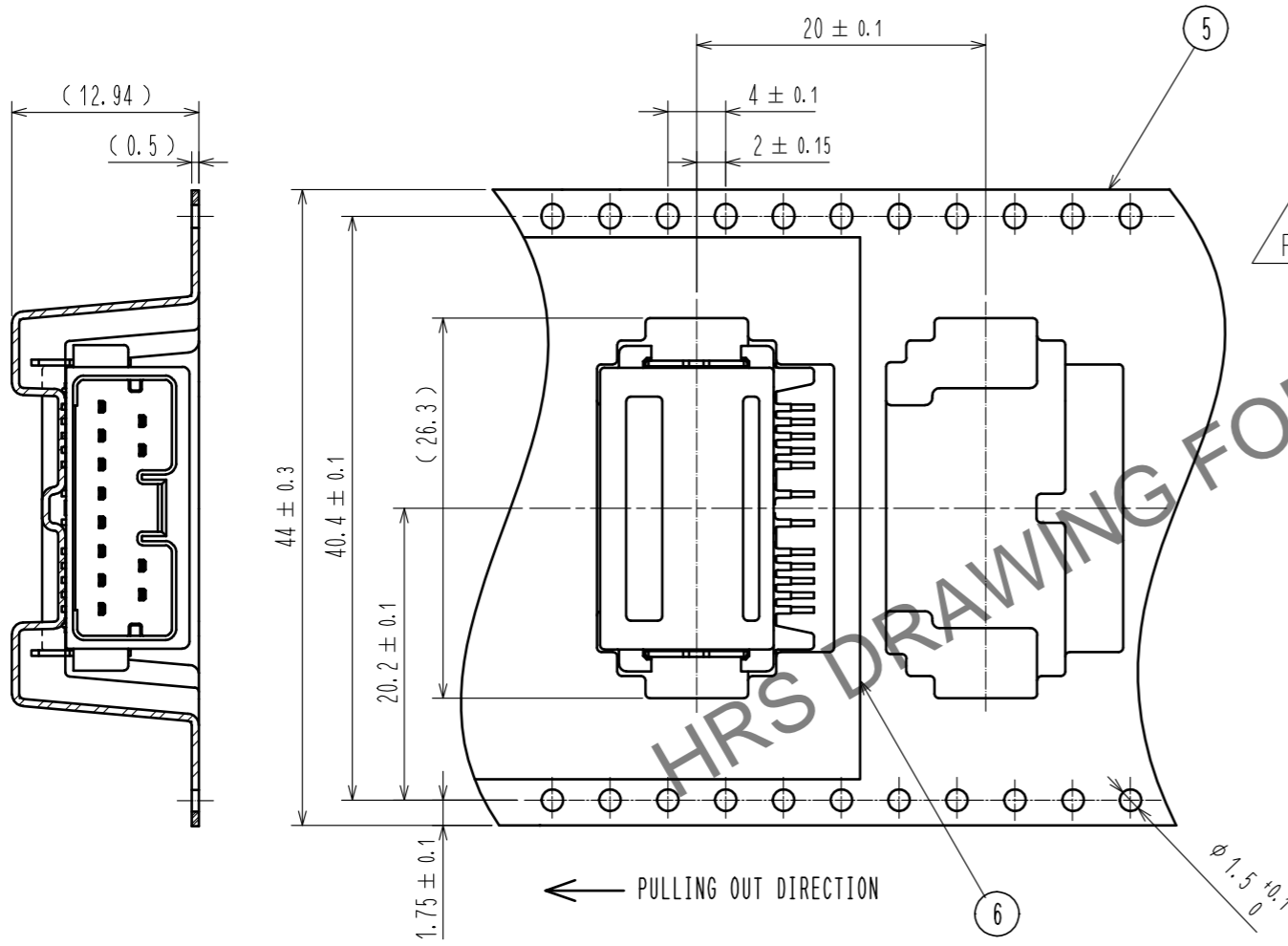

## REEL DIMENSION (FREE)

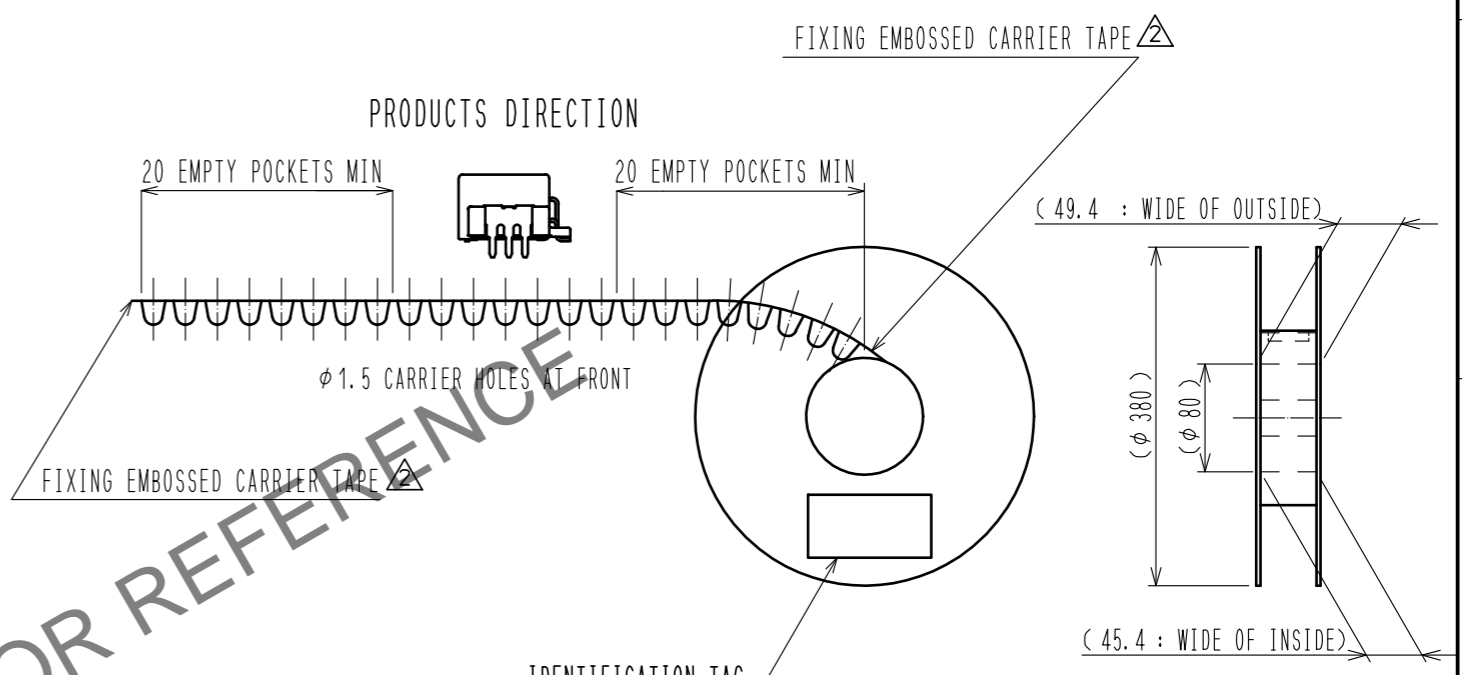

300 PCS/REEL

## CARDBOARD DIMENSION (FREE)

W=(405) (mm)  
 D=(405) (mm)  
 H=(51) (mm)

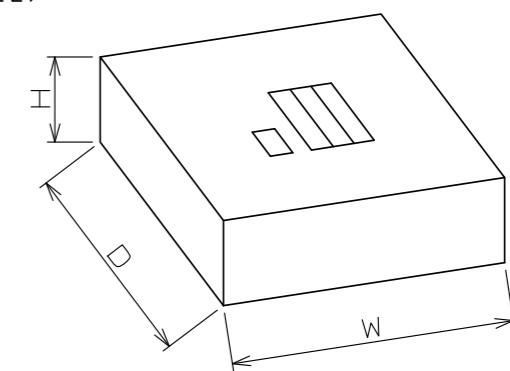

HRS DRAWING FOR REFERENCE

<b>HRS</b>	DRAWING NO.	EDC-368630-00-00	2/2
	PART NO.	ZE05-12DP-2H	
	CODE NO.	CL752-2104-0-00	