

Aug.1.2021 Copyright 2021 HIROSE ELECTRIC CO., LTD. All Rights Reserved.
In case of consideration for using Automotive equipment / device which demand high reliability, kindly contact our sales window correspondents.

ELV, RoHS COMPLIANT

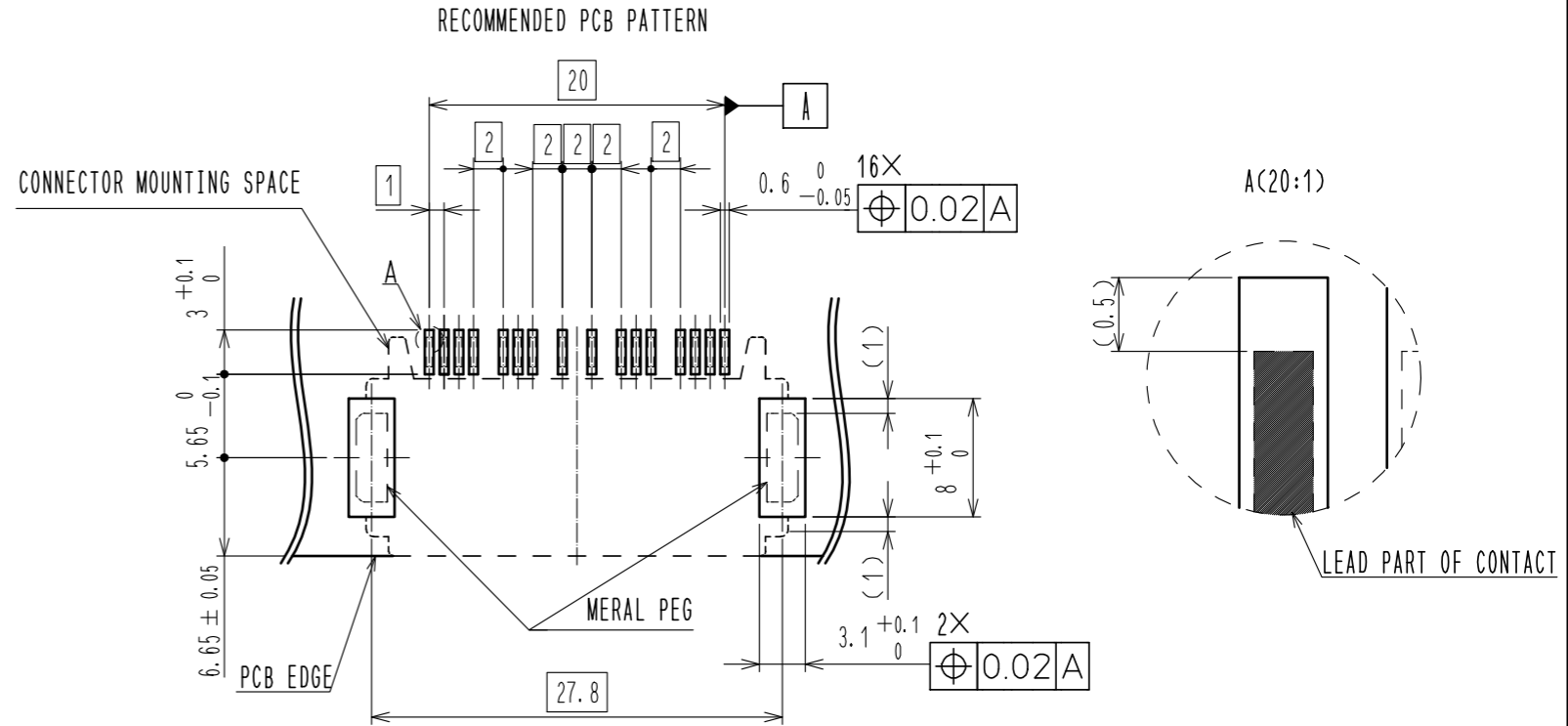

- NOTE 1. RECOMMENDED TEMPERATURE PROFILE FOR REFLOW (REFER TO RIGHT FIG.)
USED REFLOW SYSTEM : IR IN THE AIR OR NITROGEN
NO. OF CYCLES : 2 MAX
PEAK : 250°C
OVER 230°C : 20~40s
PREHEAT : 150~180°C
90~120s
2. TEMPERATURE FOR SOLDERING IRON : 280~300°C WITHIN 2s
3. CO-PLANARITY SHALL BE 0.1mm MAX.
4. RECOMMENDED PCB THICKNESS IS 1.6mm.
5. RECOMMENDED SOLDER THICKNESS IS 0.15mm.

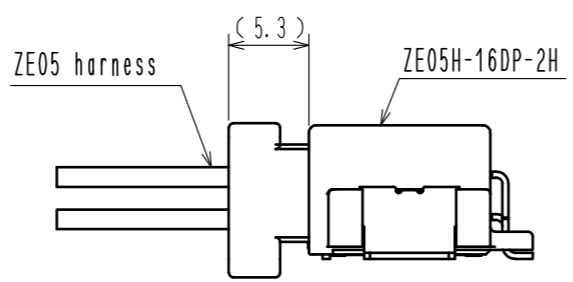
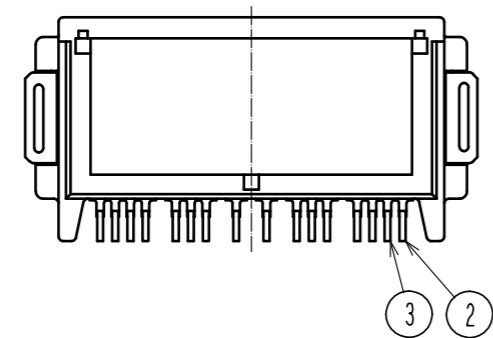
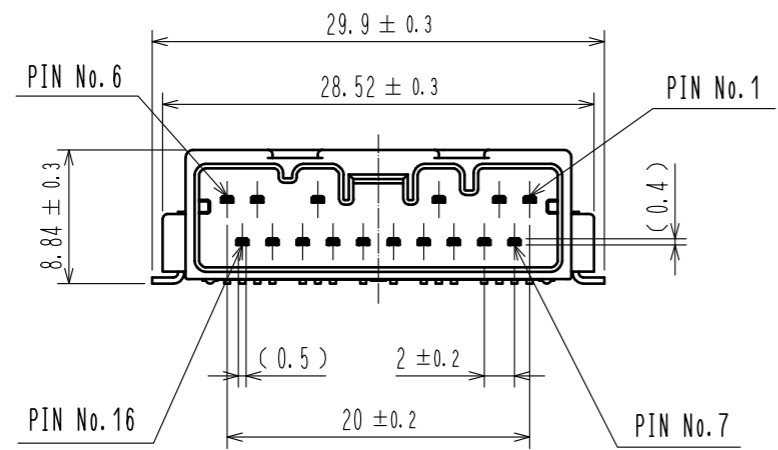
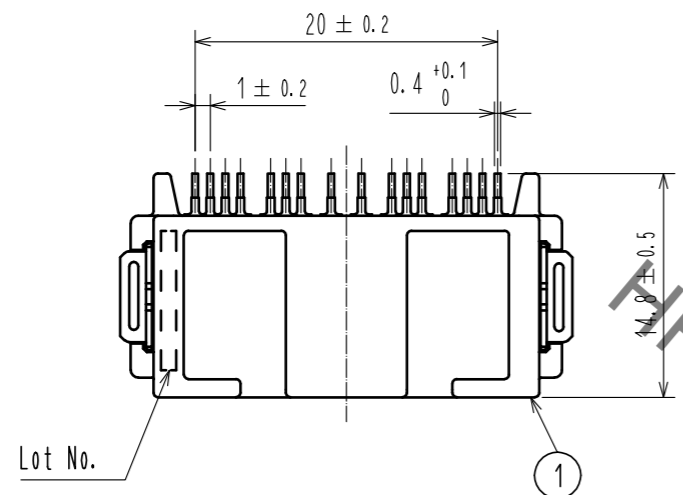
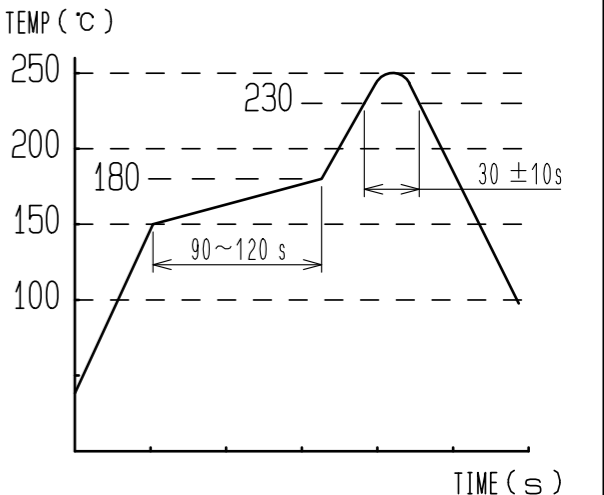

3	BRASS	SURFACE PLATING : TIN PLATING 1μm min			
		UNDER PLATING : NICKEL 1μm min	6	POLYESTER	
2	BRASS	SURFACE PLATING : TIN PLATING 1μm min	5	POLYSTYRENE	
		UNDER PLATING : NICKEL 1μm min			
1	PA	BLACK UL94V-0	4	BRASS	SURFACE PLATING : TIN PLATING 1μm min
					UNDER PLATING : NICKEL 1μm min
NO.	MATERIAL	FINISH . REMARKS	NO.	MATERIAL	FINISH . REMARKS
UNITS mm		SCALE 2 : 1	COUNT 	DESCRIPTION OF REVISIONS	DESIGNED
					CHECKED
					DATE
HRS HIROSE ELECTRIC CO., LTD.		APPROVED : HK. UMEHARA	20190607	DRAWING NO. EDC-373533-00-00	
		CHECKED : HK. UMEHARA	20190607	PART NO. ZE05H-16DP-2H	
		DESIGNED : YH. MAMADA	20190607	CODE NO. CL752-2114-0-00	
		DRAWN : MINTAE KANG	20190607	1/2	

Aug.1.2021 Copyright 2021 HIROSE ELECTRIC CO., LTD. All Rights Reserved.
In case of consideration for using Automotive equipment / device which demand high reliability, kindly contact our sales window correspondents.

PACKING STYLE

REEL DIMENSION (FREE)

PACKING STYLE DRAWING

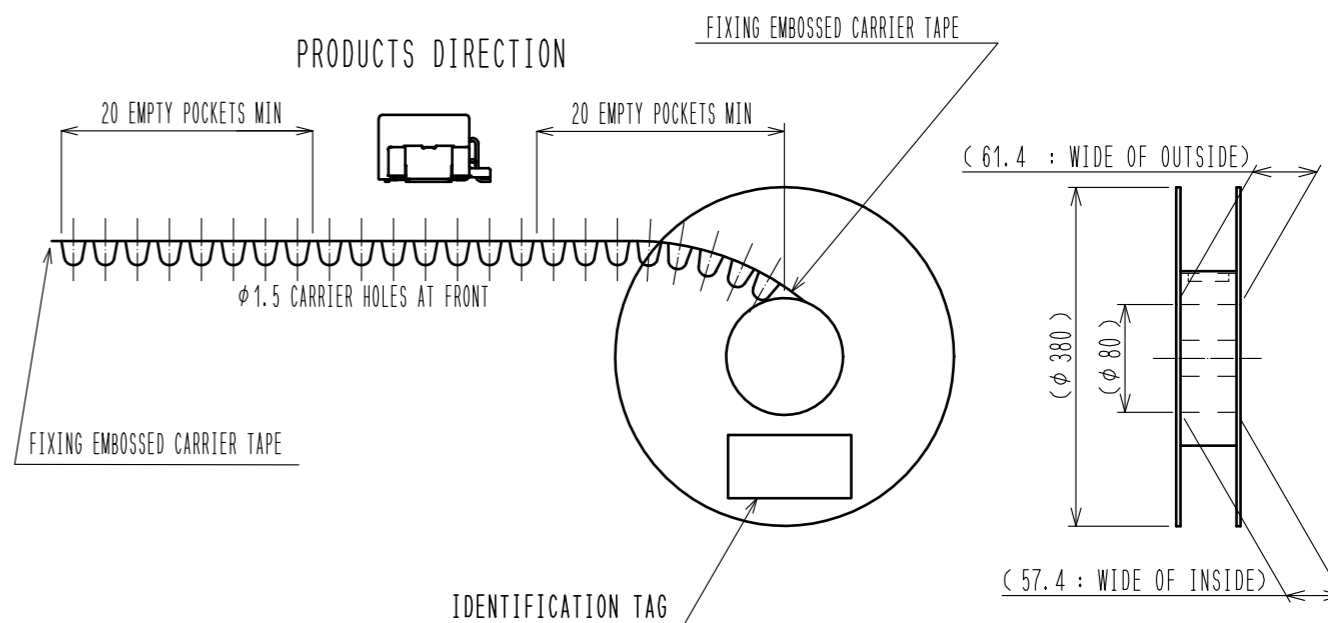
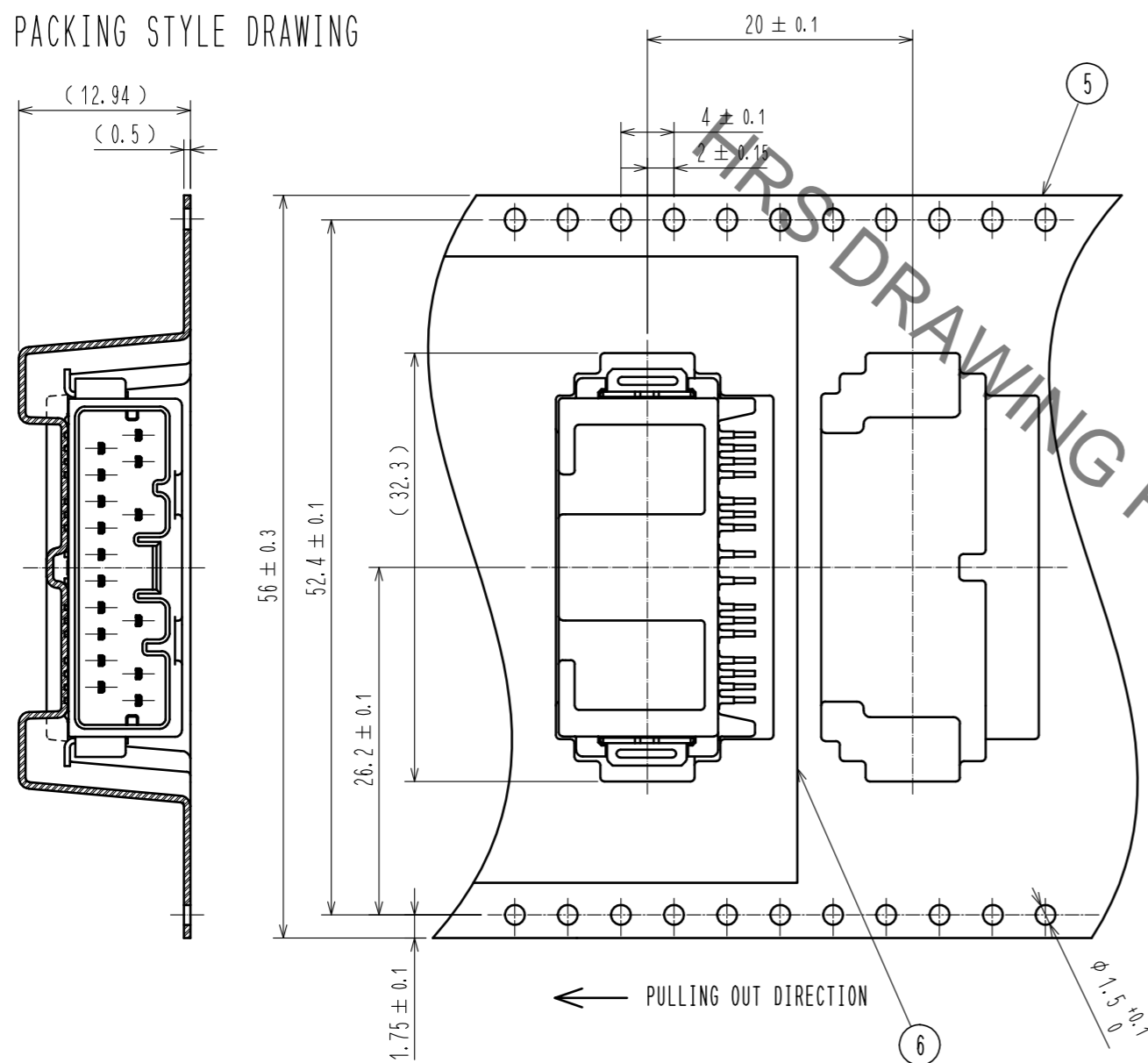

CARDBOARD DIMENSION (FREE)

W=(405) (mm)
 D=(405) (mm)
 H=(63) (mm)

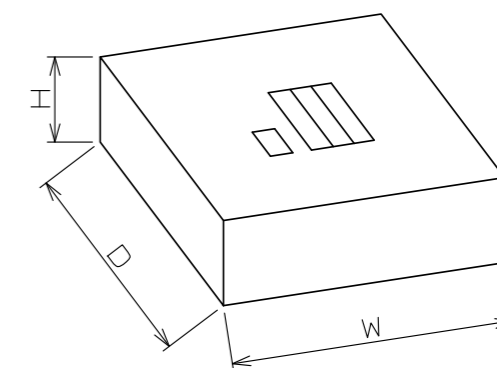

HRS DRAWING FOR REFERENCE

300 PCS/REEL

HRS	DRAWING NO.	EDC-373533-00-00	2/2
	PART NO.	ZE05H-16DP-2H	
	CODE NO.	CL752-2114-0-00	