

ZEO64W-*S-HU/R(*) INSTRUCTION SHEET

TABLE OF CONTENTS

1. PURPOSE
2. COMPONENTS
- 3-1. HARNESS ASSEMBLY PROCESS
- 3-2. HARNESS REPAIR PROCESS
4. MATING OPERATING PROCESS
5. OTHERS/NOTES

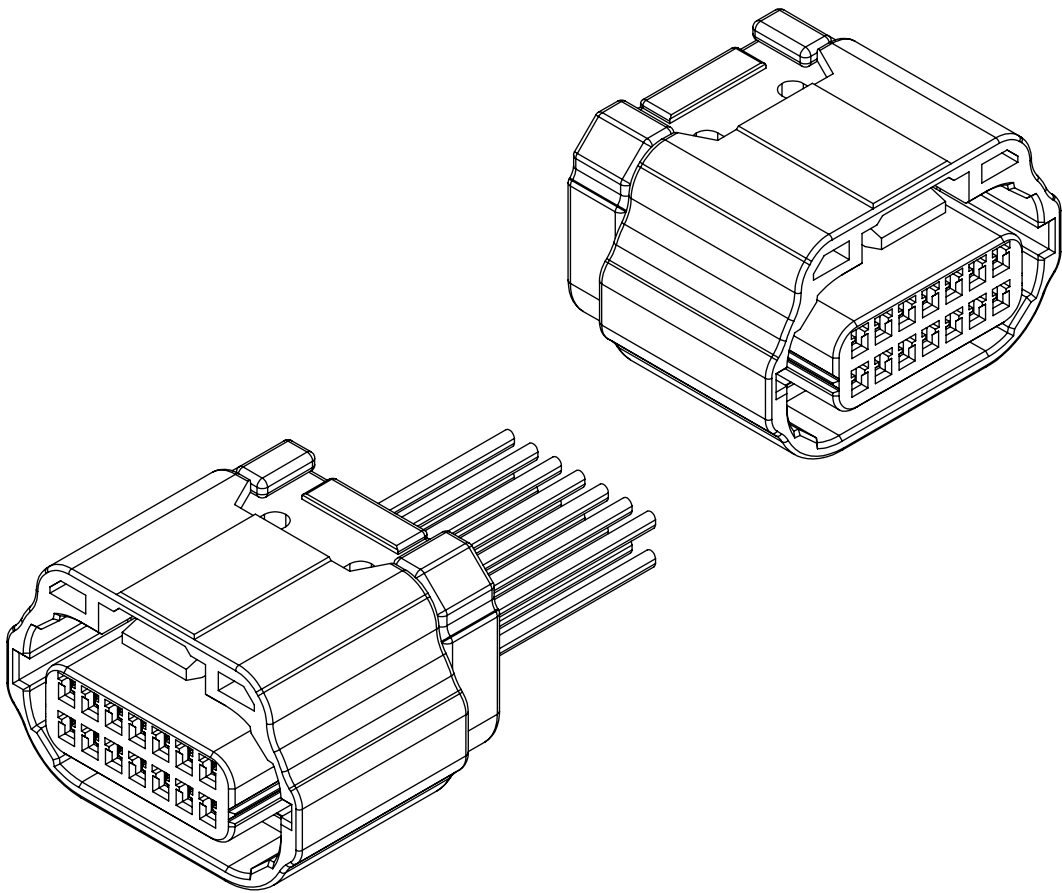

△	COUNT 1	DESCRIPTION OF REVISIONS DIS-T-00026127	DESIGNED KK. FUNADA	CHECKED TY. MOGI	DATE 2025. 12. 25
TITLE ZEO64W-*S-HU/R(*) Instruction Sheet			HRS HIROSE ELECTRIC CO., LTD.		
			APPROVED	AH. EDASHIGE	2022. 11. 14
TECHNICAL SPECIFICATION			CHECKED	TY. MOGI	2022. 11. 14
			DESIGNED	AN. SAIKI	2022. 11. 14
			WRITTEN	AN. SAIKI	2022. 11. 14
			ETAD-T0644-00	△	1 / 11

1. PURPOSE

This document provides information on the ZE64W-*S-HU/R(*) harness assembly, assembly to the panel and mating operation. Keep it on a place where it can be accessed at any time while the connector is in use.

Please note that the figures and charts shown in this document are of our representative products and may vary depending on the product types.

This document information is subject to change without notice.

2. COMPONENTS

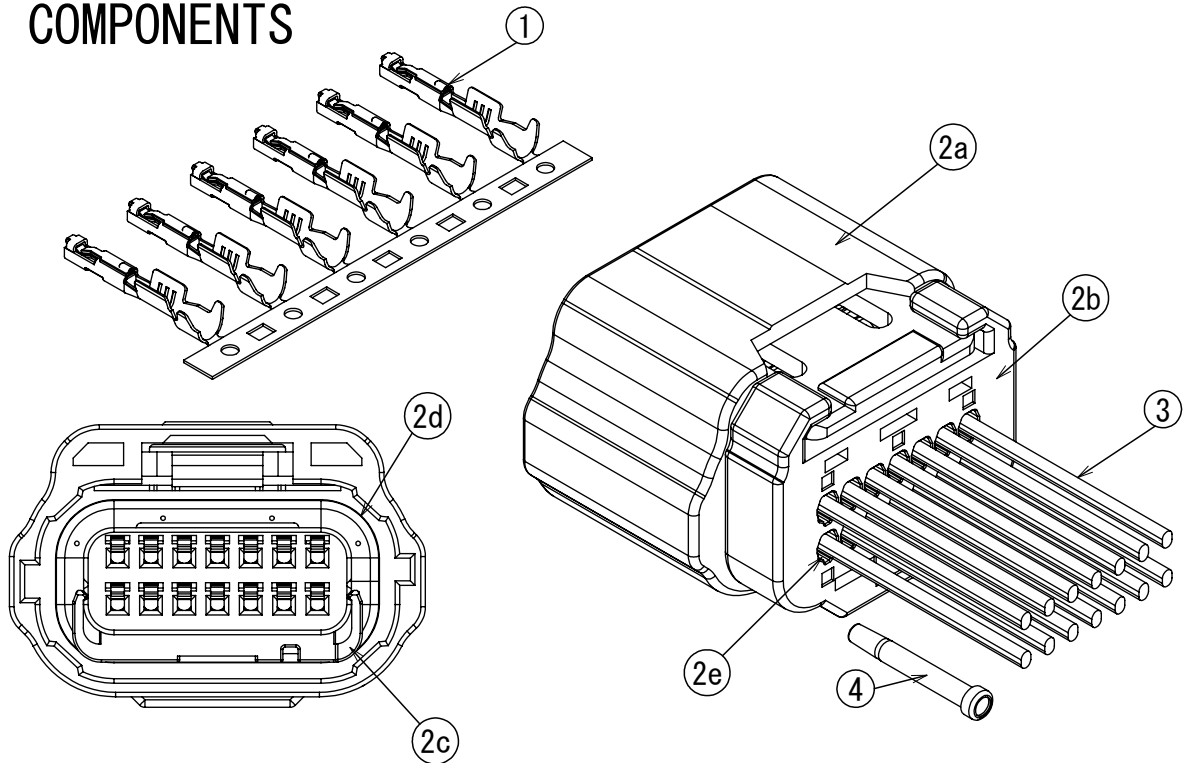

PART NO.	PART DESCRIPTION	HIROSE PART NAME		CHILD PART (COLOR)	NUMBER OF PARTS
1	CRIMP TERMINAL	ZE064-2022SCF	CL0753-2001-0-00	UNIT PARTS (SILVER)	NOT SPECIFIED
		ZE064-2022SCFA	CL0753-2027-0-00	OLDUNIT PARTS (SILVER/GOLD)	
2	FEMALE CONNECTOR	ZE064W-8DS-HU/R (A)	CL0753-2015-0-00	2a:HOUSING (BLACK or GREY)	1
		ZE064W-8DS-HU/R (B)	CL0753-2016-0-00	2b:BACK COVER (GRAY)	
		ZE064W-14DS-HU/R (A)	CL0753-2010-0-00	2c:RETAINER (BEIGE)	
		ZE064W-14DS-HU/R (B)	CL0753-2011-0-00	2d:PANEL SHEEL (RED OXIDE)	
		ZE064W-24DS-HU/R (A)	CL0753-2005-0-00	2e:WIRE SHEEL (RED OXIDE)	
		ZE064W-24DS-HU/R (B)	CL0753-2006-0-00		
3	CABLE	—	—	—	NOT SPECIFIED
4	WATERPROOF PIN	ZE064W-WCP (2022)	—	—	NOT SPECIFIED

HRS	DRAWING NO.	ETAD-T0644-00		
	PART NO.			
	CODE NO.			
		3	2	11

3-1. HARNESS ASSEMBLY PROCESS

Note: Regarding crimping information, please refer to 'ETAD-T0667-00'

Crimping quality standard.

Please refer to the crimping condition table for the compatible wires and crimping conditions confirmed by our tools.

① Cut the cable

Set the cable length with reference to the dimensions shown on the right.

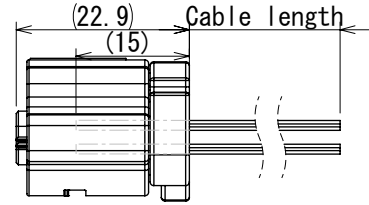

Approximate cable cut length = above cable length + 15mm

② Strip cable and crimp the terminal to the cable.

Please refer to 'Crimp quality standard' and 'Crimping condition table' for details.

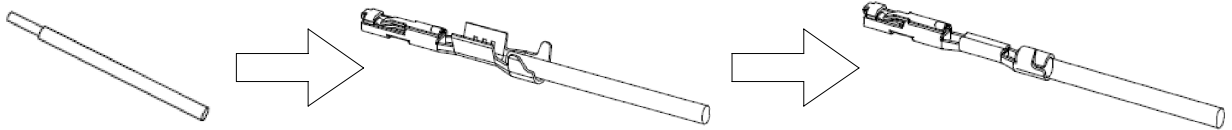

Note: Please use Hirose Crimp tool.

③ Pick a connector from tray.

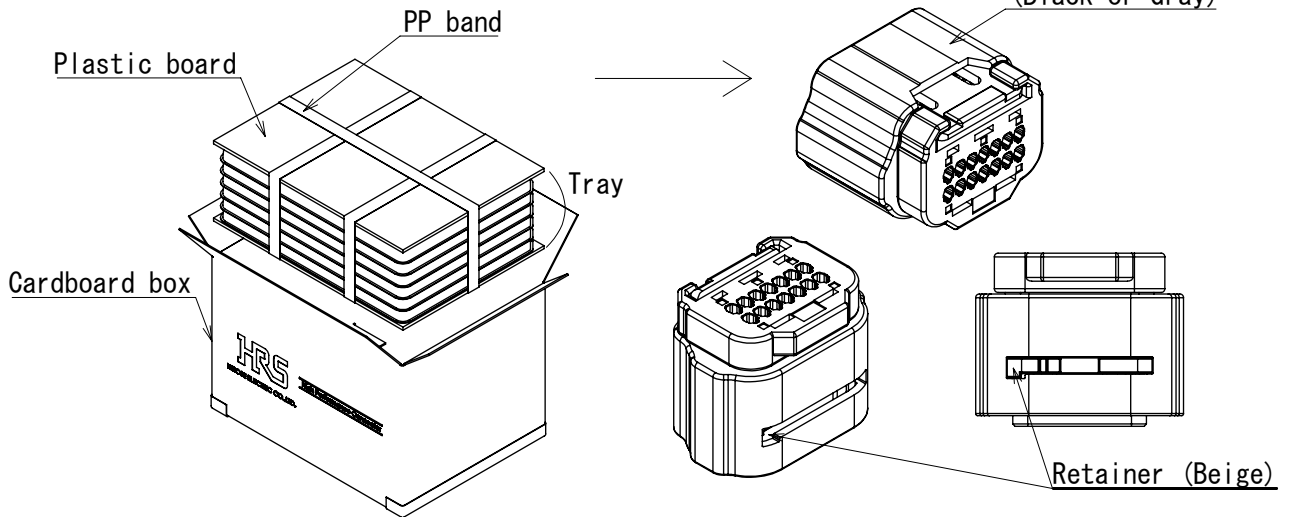

④ Insert the terminal straight to the housing. (refer to below direction)

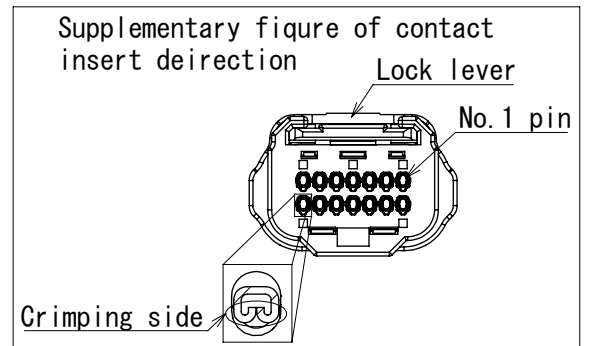
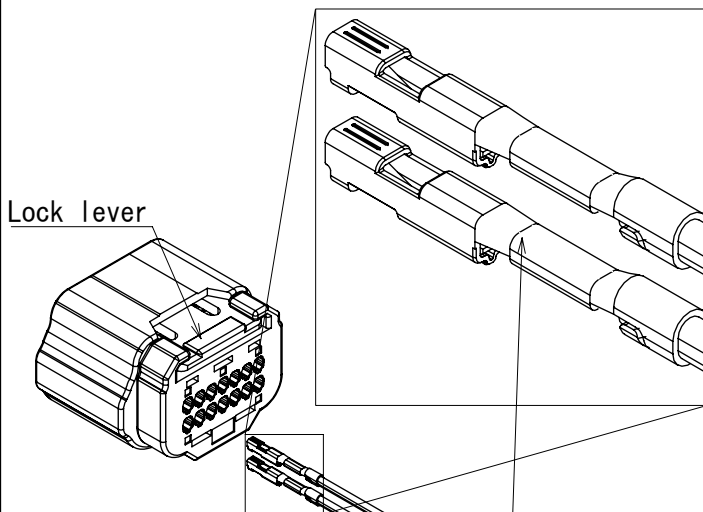

The terminal is inserted with the crimping portion facing opposite side of lock lever.

Note: Please hold the cable and insert it straight

HRS	DRAWING NO.	ETAD-T0644-00	
	PART NO.		
	CODE NO.		
			3

⑤After inserting the terminals, check the terminals are correctly inserted from the mating side of connector.

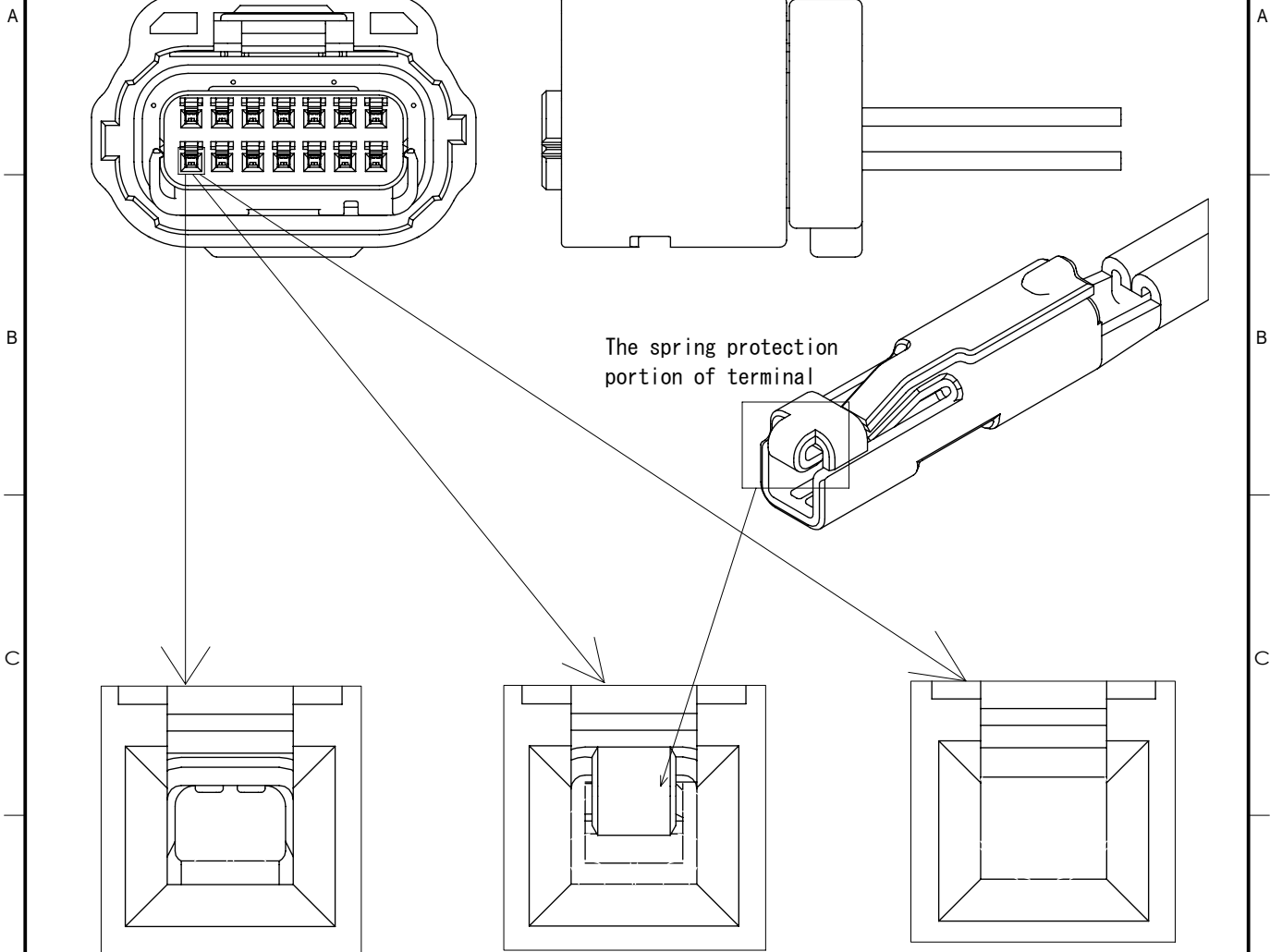

【OK】 The terminal is correctly inserted.
Appearance: The frame of the female terminal looks almost square.

【NG】 The terminal is inserted upside down.
Appearance: The spring protection portion of terminal shows at lock lever side
⇒At this condition, the terminal is locked in the housing, the terminal can not remove from the housing.
Please replace new housing and new terminal.
In addition, if you try to insert the terminal in this direction, the terminal insertion force will be higher than in the normal direction.

【NG】 The terminal is not fully inserted.
Appearance: The terminal is not clearly visible.
⇒Please insert the terminal fully until visible.

HRS	DRAWING NO.	ETAD-T0644-00	
	PART NO.		
	CODE NO.		
		3	4 11

⑥As shown in the figure below, please push the center of preset retainer to use the flat part of dedicated tool until you hear locked sound.
 When the terminal is inserted correctly, the insertion force of retainer is under 20N.
 Please do not exceed the insertion force more than 29.4N, or the terminal or housing might be deformed and you can not detect partial insetion of terminal or terminal insert upside down.

Schematic diagram of retainer push-in method

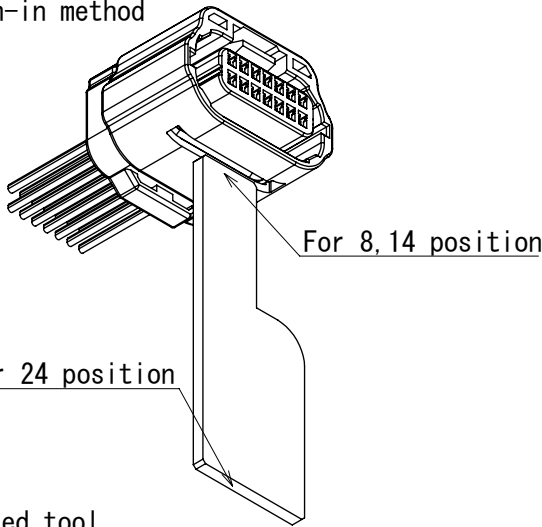

Connector cross section

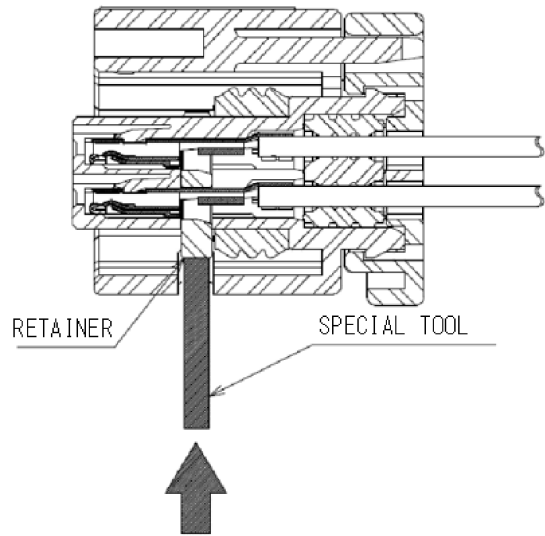

Push the dedicated tool in the direction of the arrow

Dedicated tool appearance and dimitions (mm)

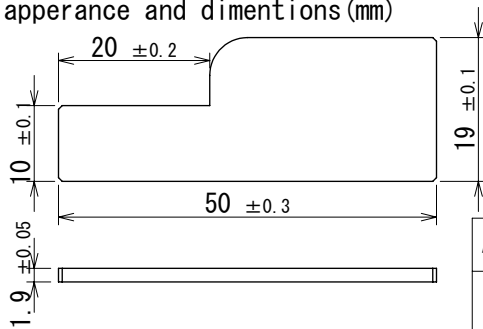

Dedicated tool information for pushing and releasing the retainer

Applicable products	Product name	Part number
ZE064W-*S-HU/R(*)	ZE064W-DS-HU/R/CV-MD	CL0902-5151-0-00

⑦After setting the retainer, please make sure the retainer is not tilted as seen from the front.
 The retainer does not set because it is conflict with terminal when the terminal is not inserted completely or the terminal is upside down.
 If so, the retainer pops up approx. 0.4mm.
 Please run again process 5 and 6, when the retainer does not set up correctly.

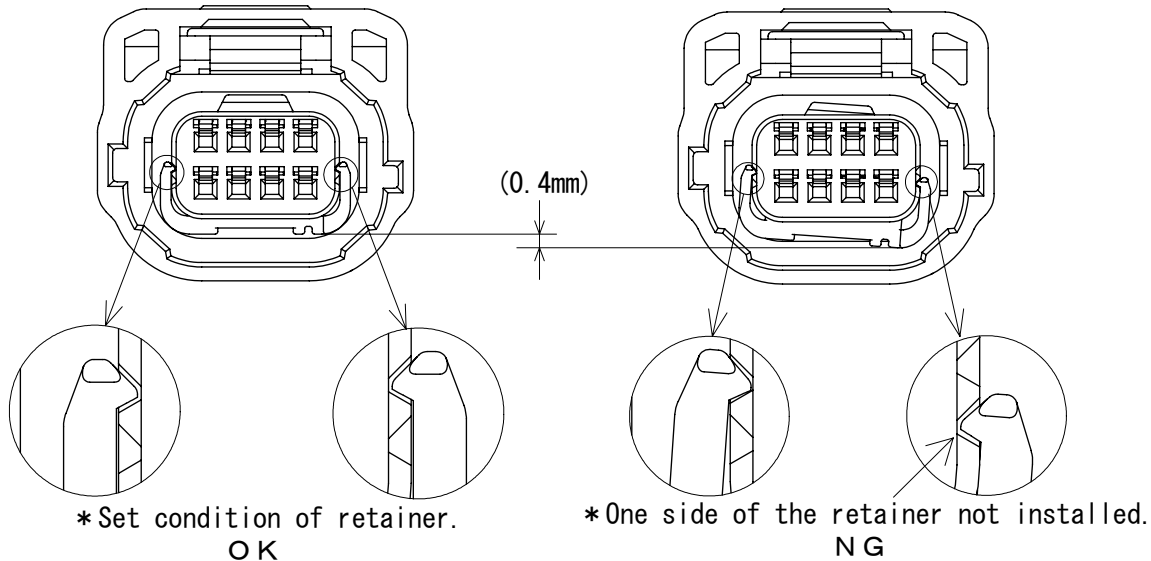

HRS	DRAWING NO.	ETAD-T0644-00	
	PART NO.		
	CODE NO.		
		3	5
		11	

⑧ If the terminal hole has empty, please insert the waterproof pin to prevent a water entry. The water proof pin installs straitly until it hits as shown. The waterproof pin does not have rotational direction of restriction.

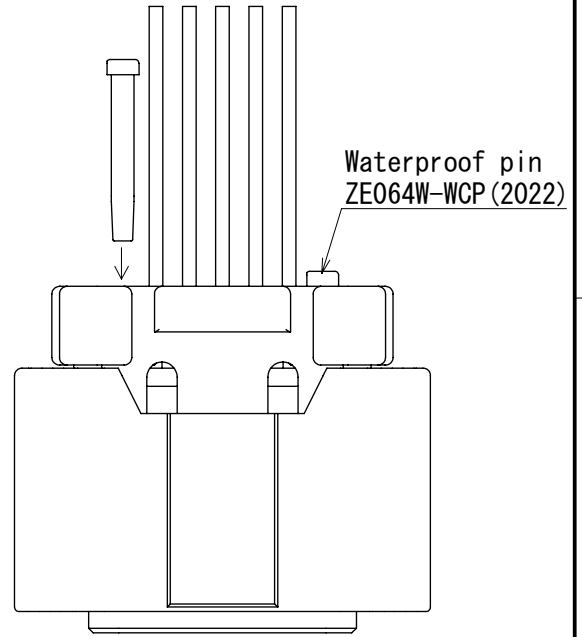

⑨ For eletctrical tests, please touch the test probe to the tip of female terminal. During electrical tests, please take care of damage or deform the connector or terminals.

The recommended probe should have the following characteristics.

- Diameter : $\phi 0.3 \sim 0.6$
- Touch surface : Flat
- Plating : Gold plated
- Spring force : 1N Max.
- Stroke : See figure below

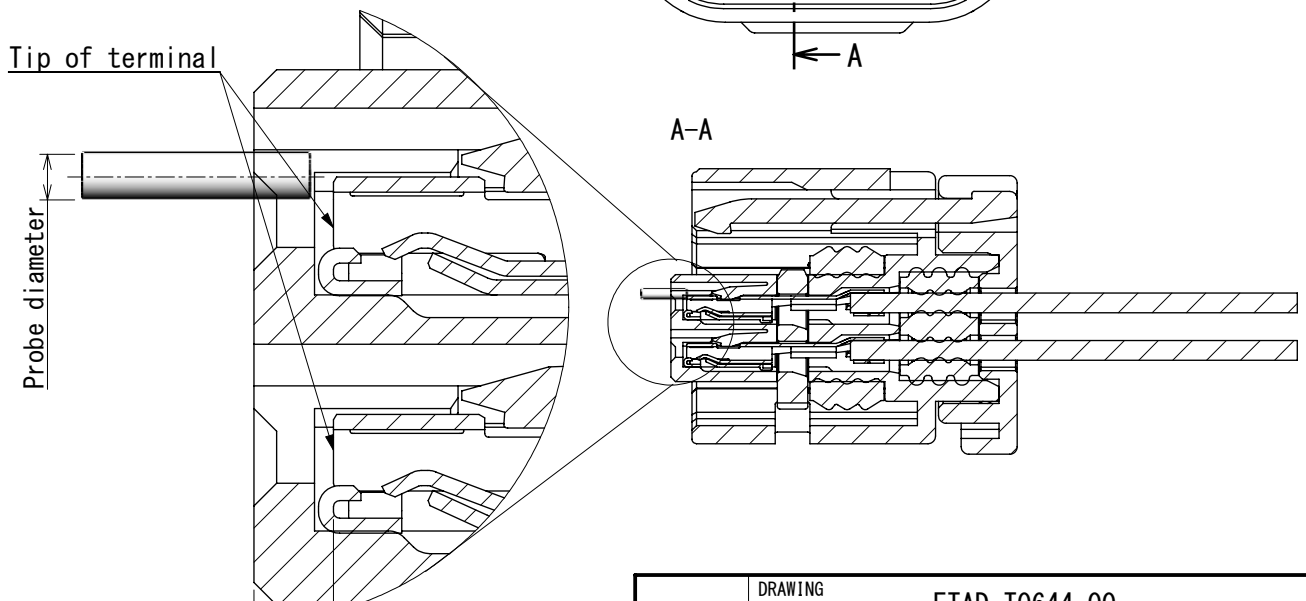
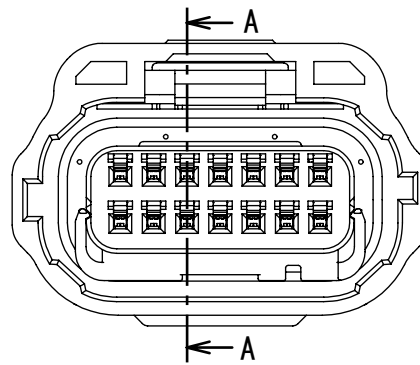

HRS	DRAWING NO.	ETAD-T0644-00	
	PART NO.		
	CODE NO.		
		3	6
		11	

The test probes should be located in front face as described below.

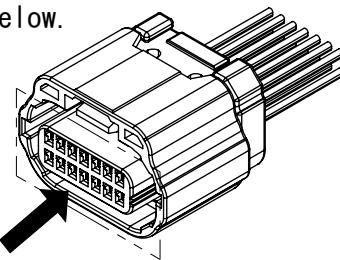

Front face

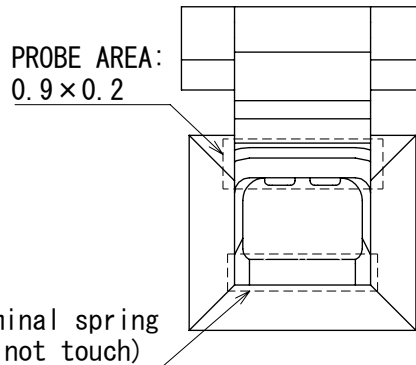
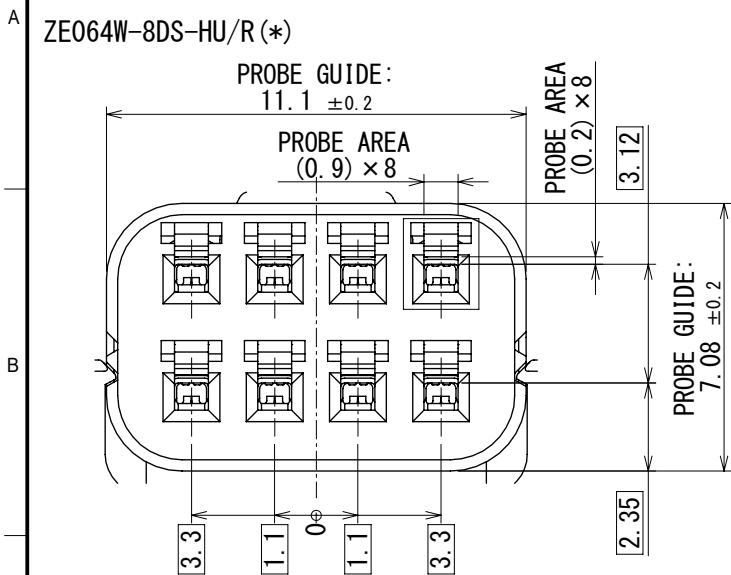

Enlarged of PROBE AREA

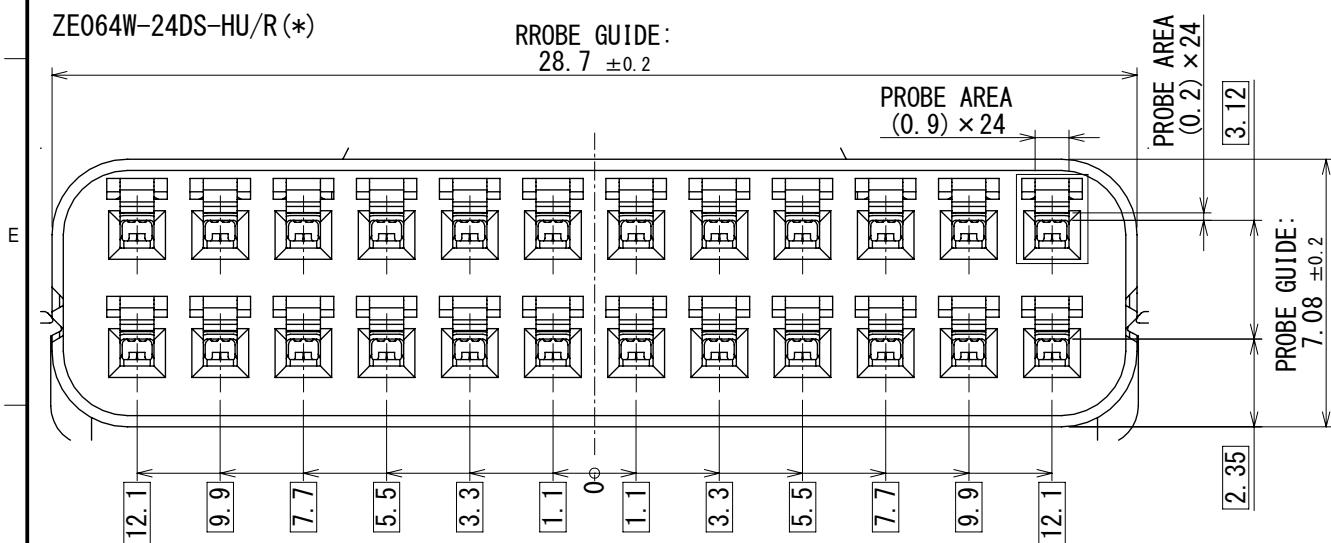
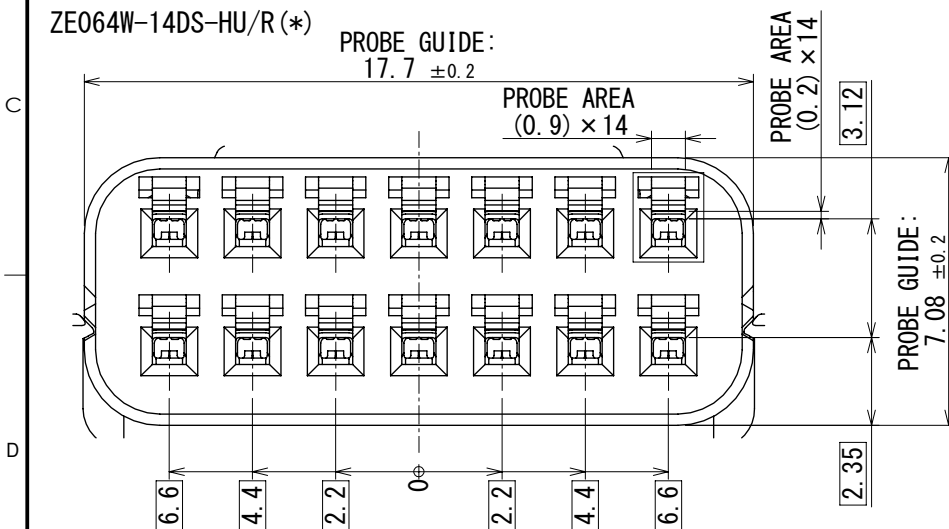

HRS	DRAWING NO.	ETAD-T0644-00	
	PART NO.		
	CODE NO.	3	7
		11	

3-2. HARNESS REPAIR PROCESS

- ① Use the retainer release tool to unlock the retainer and return it to the preset condition.

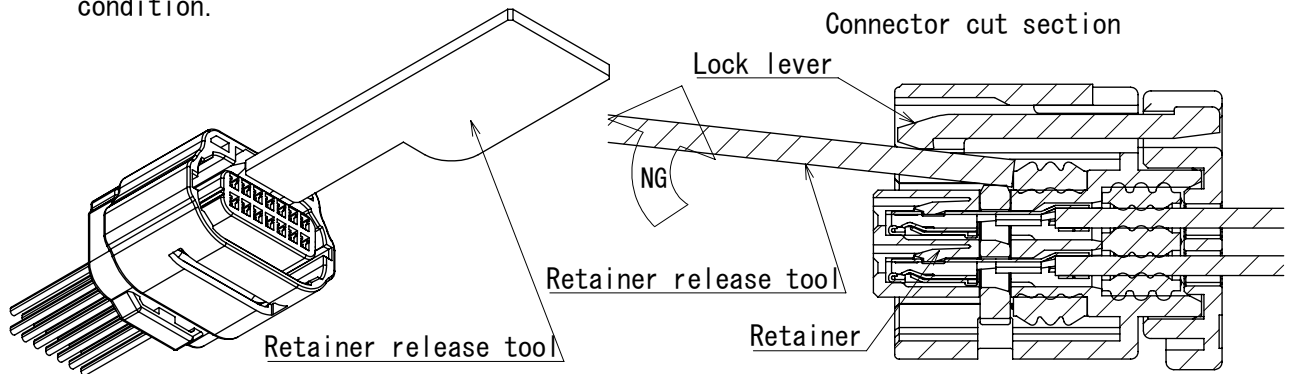

The retainer release tool into the housing (lock lever side), push down the retainer. Please be careful not to damage or deform the housing seal.

Please do not tilt the retainer release tool in the direction shown above to prevent an excessive deformation of lock lever.

Make sure that the retainer is in the pre-set state for both left and right.

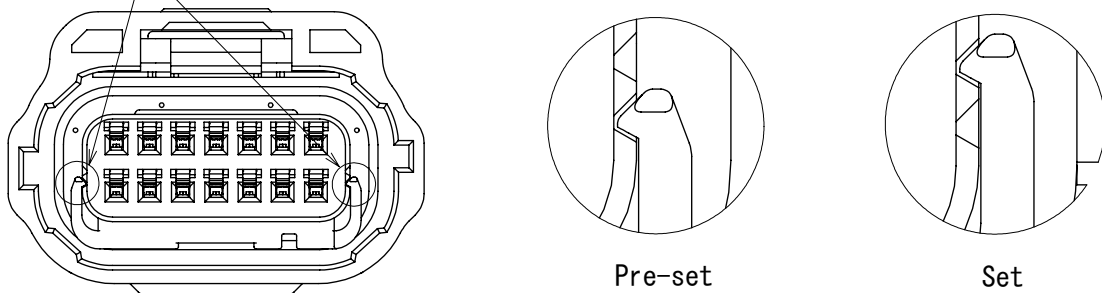

Note: If the retainer is dropped out, please return the pre-set position.

Dedicated tool information for pushing and releasing the retainer

Applicable products	Product name	Part number
ZE064W-*S-HU/R(*)	ZE064W-DS-HU/R/CV-MD	CL0902-5151-0-00

- ② Inset the repair tool into the repair tool insertion hole, and push until it hits. And then, please remove the terminal while maintaining that state.

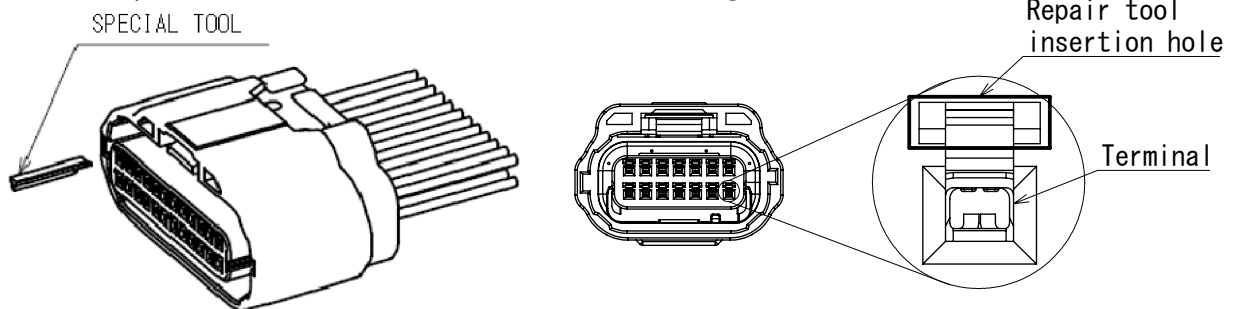

Note: The number of insertions into the same terminal hole is up to 2 times. Exceed 2 times, please replace new housing.

HRS	DRAWING NO.	ETAD-T0644-00	
	PART NO.		
	CODE NO.		
		3	8 11

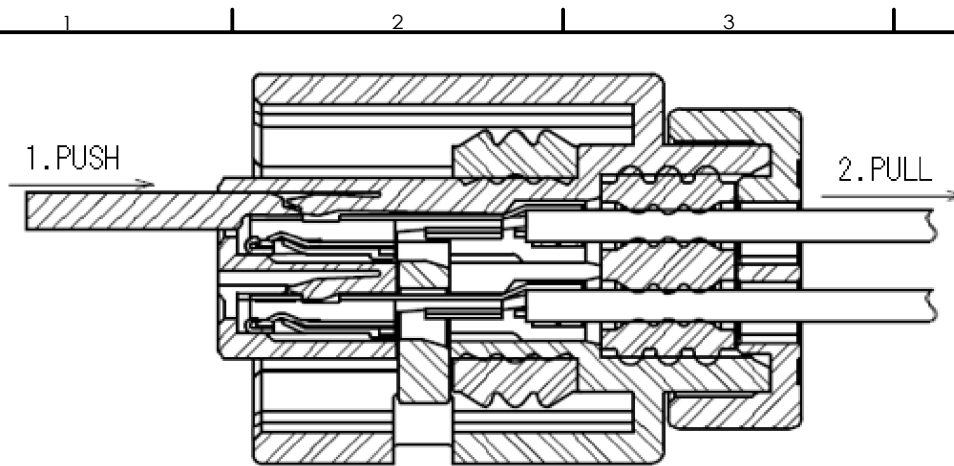

Repair tools information

Applicable products	Product name	Part number
ZE064-2022SCF	ZE064-S/RE-MD	CL-0902-5149-0-00
ZE064-2022SCFA		

4. MATING OPERATING PROCESS

- ① Prepare a panel with a male connector attached and a female connector harness product. Make sure that the male and female connector key coding are the same. Align the locking direction of male and female connectors and insert them straight along the mating direction.

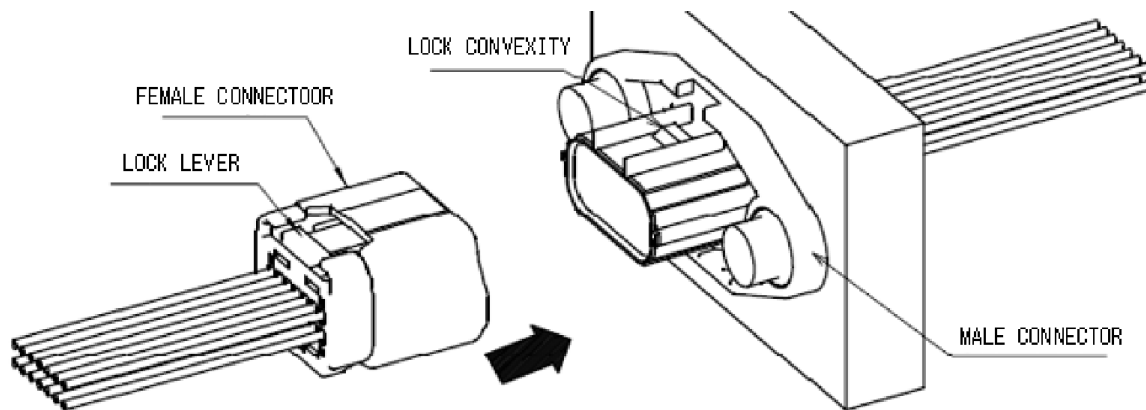

HRS	DRAWING NO.	ETAD-T0644-00	
	PART NO.		
	CODE NO.		
		3	9 11

② Please insert the connectors until they butt against each other.
The connector will be locked.

※ Do not touch the female connector lock lever when inserting the connector.
This makes it difficult to recognize the lock feeling and may cause half insertion.

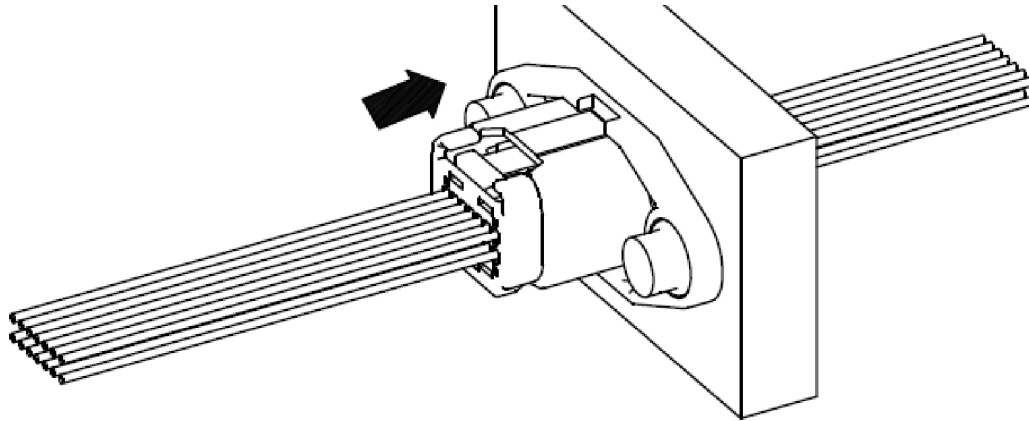

③ When disconnecting the connector, push down the lock lever of female connector until it touches the bottom surface of it, then grasp the female connector housing and pull it out straight against the mating direction.

※ If the female connector is removed while the lock lever is not pushed down enough, it may cause damage to the locking portion.

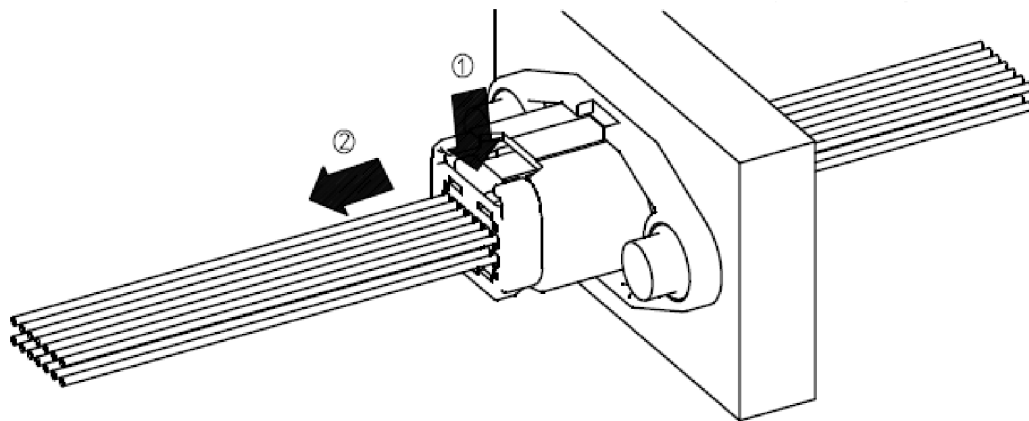

⚠ ※ Do not insert claws or sharp tools between the HOUSING and the BACK COVER, as this may cause damage to the BACK COVER.

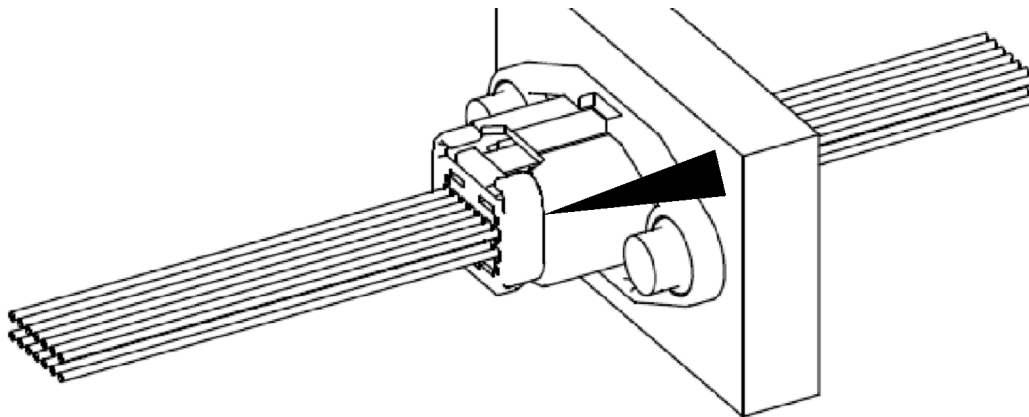

HRS	DRAWING NO.	ETAD-T0644-00	
	PART NO.		
	CODE NO.		

5. OTHERS / NOTES

- 1) Do not touch the terminal contacts and the inside of the barrel.
- 2) Wear hand gloves or finger coat when touching the terminals to prevent corrosion.
- 3) Handle the terminals carefully to avoid deformation or dirt sticking by putting things on or dropping.
- 4) If the terminals are caught each other, please do not try to pull out roughly, but loosen them carefully.
- 5) Be careful not to deform the terminal when touching it.
- 6) Cables with crimped terminals need to be kept carefully so that terminals do not catch each other.
When the cables are banded, make sure the stress is not applied on terminals.
- 7) Please be careful not give a big shock.
- 8) Avoid storing in dusty places.
- 9) Please do not place wire harness on the floor.
- 10) Avoid handling that causes deformation or scratches of housing, or deformation of the terminal.
- 11) When installing the harness, it is recommended to clamp it within 100mm from the neck bottom of connector.
- 12) Please don't drop the packaged product from 40cm height to avoid product deformation.

	DRAWING NO.	ETAD-T0644-00	
	PART NO.		
	CODE NO.		