

Apr.1.2025 Copyright 2025 HIROSE ELECTRIC CO., LTD. All Rights Reserved.  
 In case of consideration for using Automotive equipment / device which demand high reliability, kindly contact our sales window correspondents.

ELV·RoHS COMPLIANT

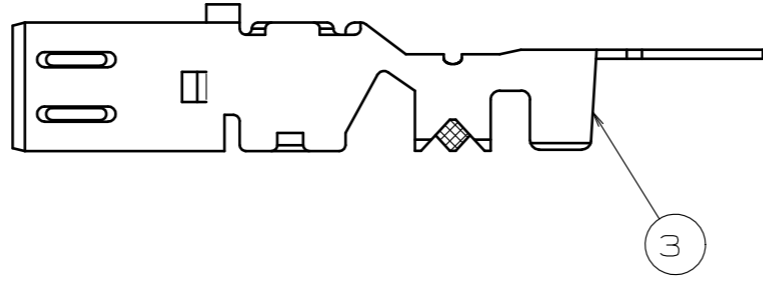
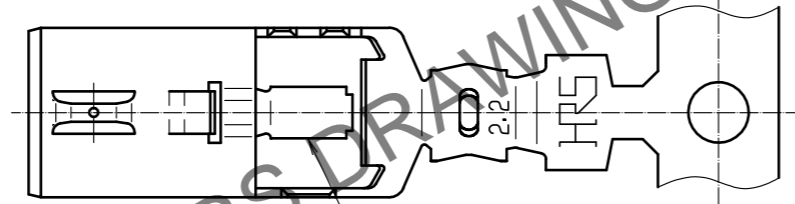
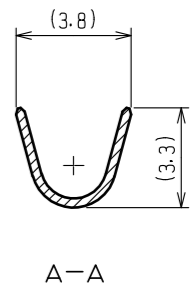
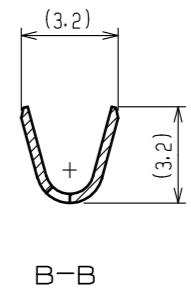
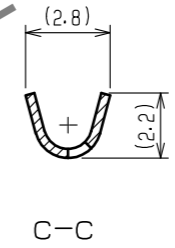
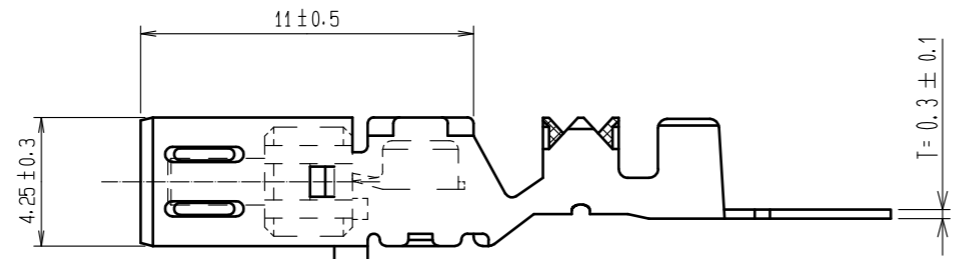
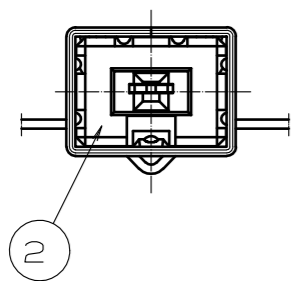
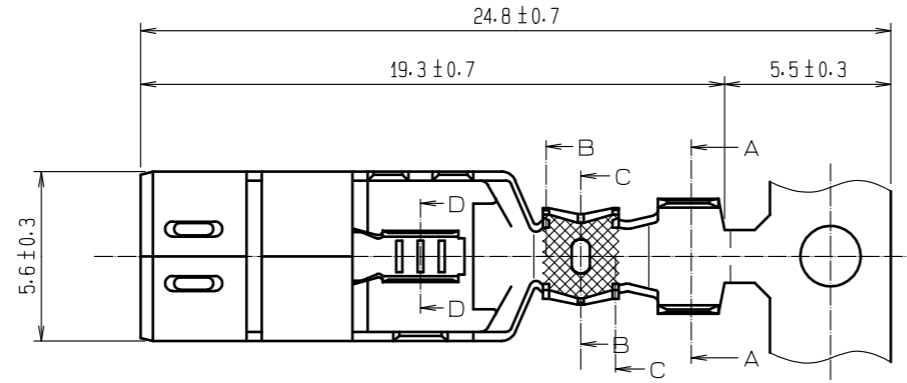

NOTES  
 1. PER REEL : 3000 CONTACTS.  
 2. THIS REEL DIAMETER SHALL BE  $\phi 750$ , AND CRIMPING MACHINE NEEDS ADDITIONAL PARTS AS CM105/RS-GT.

1	Cu ALLOY	TIN PLATING	3	Cu ALLOY	TIN PLATING			
2	PBT	DARK GRAY	2	PBT	DARK GRAY			
NO.	MATERIAL	FINISH . REMARKS	NO.	MATERIAL	FINISH . REMARKS			
UNITS mm			SCALE 4 : 1	COUNT 	DESCRIPTION OF REVISIONS	DESIGNED	CHECKED	DATE
<b>HRS</b> HIROSE ELECTRIC CO., LTD.		APPROVED : KI. HIROKAWA 20200327	DRAWING NO. EDC-166790-55-00					
		CHECKED : MO. OKADA 20200327	PART NO. GT13L-2428/1.1-2.2SCF(55)					
		DESIGNED : NK. IKUTA 20200327	CODE NO. CL763-0115-2-55					
		DRAWN : YK. MITSUISHI 20200318						