



# Contents list

1. Part name
2. Parts composition
3. Assembly process
4. Continuity check
5. Repair process
6. Connector mating method
7. Connector un-mating method
8. Remarks
9. Storing

	COUNT	DESCRIPTION OF REVISIONS	DESIGNED	CHECKED	DATE
	4	DIS-T-00013284	TY. MOGI	HK. UMEHARA	20220315
名 称      TITLE Handling manual for GT25 plug connector			 HIROSE ELECTRIC CO., LTD.		
			APPROVED	AR. SHIRAI	20130131
			CHECKED	TY. TAKAHASHI	20130131
			DESIGNED	TY. SAKASHITA	20130128
			WRITTEN	TY. SAKASHITA	20130128
技 術 指 定 書      TECHICAL SPECIFICATION			ETAD-T0329		 1 / 11

1. Part name

GT25H FEMALE CRIMPING CONTACT

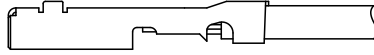

GT25 FEMALE HOUSING

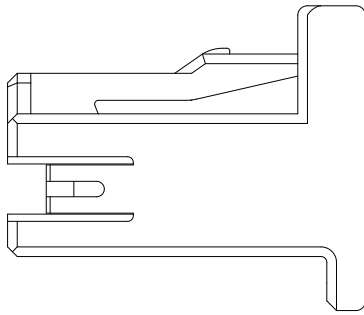

GT25 RETAINER



GT25 FEMALE HOUSING WITH RETAINER

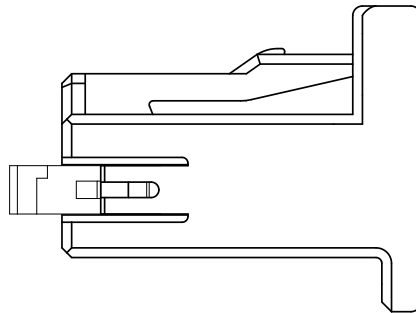

May. 1. 2022 Copyright 2022 HIROSE ELECTRIC CO., LTD. All Rights Reserved.

## 2. Parts composition

### GT25H FEMALE CRIMPING CONTACTS

Products name	Products No.	Remarks
GT25H-2024SCF	CL775-0039-6-00	0.3~0.5SQ
GT25HB-2428SCF	CL775-0070-6-00	0.13~0.22SQ

### GT25 FEMALE HOUSINGS

Products name	Products No.	Remarks
GT25-8DS-HU	CL775-0064-3-00	For 8 pos.
GT25-12DS-HU	CL775-0037-0-00	For 12 pos.
GT25-12DS-HU(50)	CL775-0037-0-50	For 12 pos.
GT25-16DS-HU	CL775-0066-9-00	For 16 pos.
GT25-24DS-HU	CL775-0068-4-00	For 24 pos.
GT25-32DS-HU	CL775-0042-0-00	For 32 pos.

### GT25 RETAINERS

Products name	Products No.	Remarks
GT25-8DS-R	CL775-0065-6-00	For 8 pos.
GT25-12DS-R	CL775-0041-8-00	For 12 pos.
GT25-16DS-R	CL775-0067-1-00	For 16 pos.
GT25-24DS-R	CL775-0069-7-00	For 24 pos.
GT25-32DS-R	CL775-0043-3-00	For 32 pos.

### GT25 FEMALE HOUSINGS WITH RETAINERS

Products name	Products No.	Remarks
GT25-8DS-HU/R	CL775-0059-3-00	For 8 pos.
GT25-12DS-HU/R	CL775-0062-8-00	For 12 pos.
GT25-12DS-HU/R(50)	CL775-0062-8-50	For 12 pos.
GT25-16DS-HU/R	CL775-0063-0-00	For 16 pos.
GT25-24DS-HU/R	CL775-0046-1-00	For 24 pos.
GT25-32DS-HU/R	CL775-0044-6-00	For 32 pos.

Please apply to our sales person about developmental status of products.

### 3. Assembly process

3-1. Insert retainer to GT25 female housing at the point of preset position.

Click feeling is available at both side of retainer.

After retainer insertion, check the retainer which don't drop off from housing by own weight.

Note) When retainer insertion is deeper then preset position, you can't insert female contacts.

In case of the housing with retainer chosen, you don't need this process.

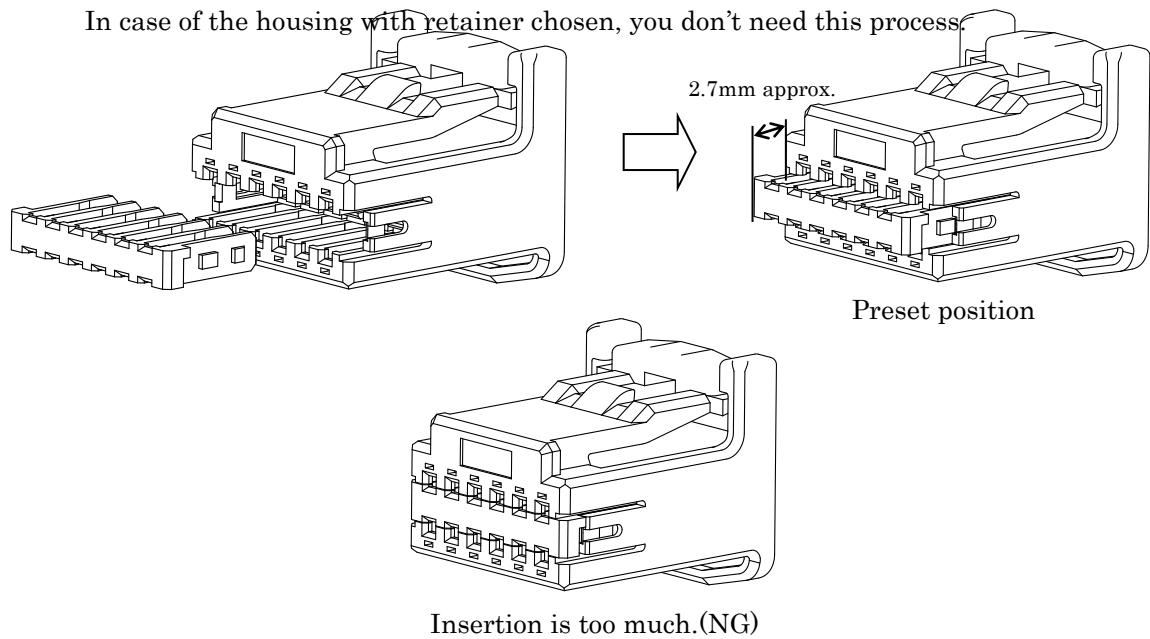

3-2. Regarding the crimping process, please refer to the "Crimp Quality Standrd"(ATAD-T0302) and the "Crimp Condition".

Cable Cut Length is  $L + 10(\text{mm})$ .

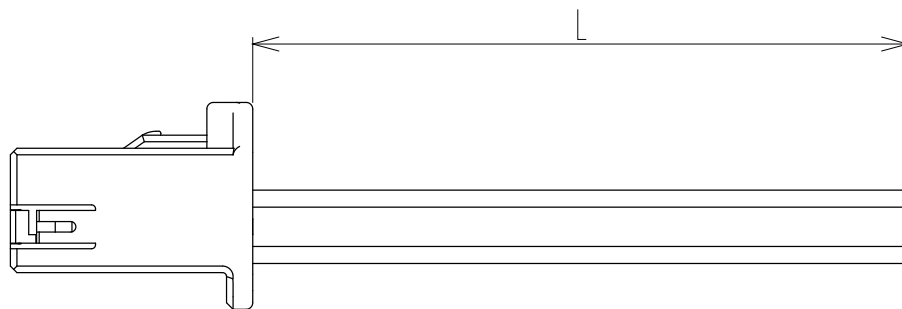

3-3. Insert female contacts to GT25 housing.

Keep the stabilizer upper, inserting to upper cavity.

Keep the stabilizer lower, inserting to lower cavity.

Insert contacts until you feel the click.

Note) Cable pulling force is 20N MAX for check.

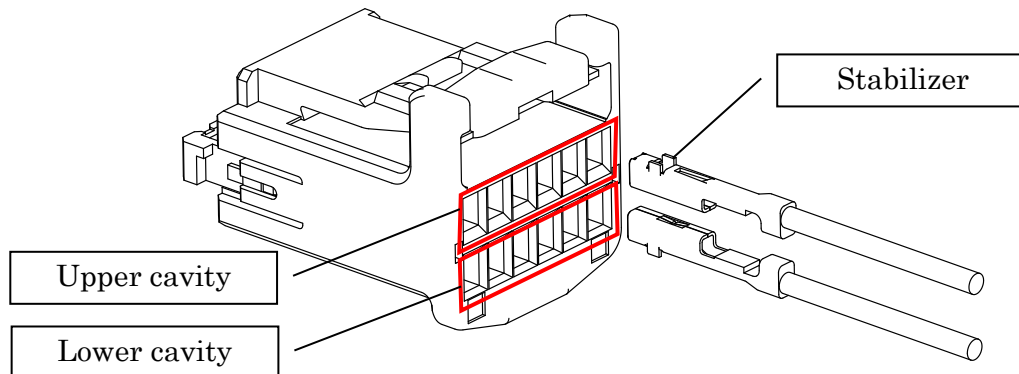

Note) Contacts stop at position of following figure,

when you mistake contact's direction of insertion.

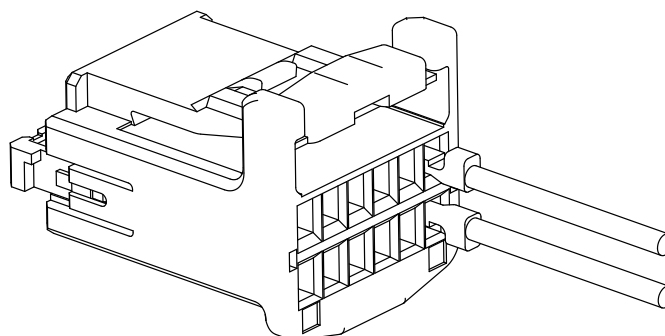

3-4. After contacts insertion, push the retainer

until you feel the click and retainer is locked by housing lock.

Note) You can't insert retainer perfectly which stick out about 2mm,

if contacts aren't locked perfectly by housing lance.

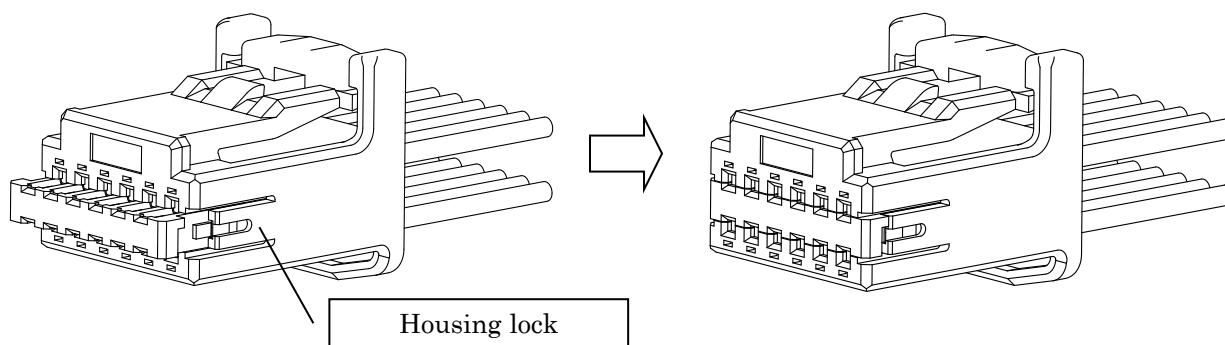

#### 4. Continuity check

Check the conduction to insert the probe up to 3.3mm.

Adapted probe diameter :  $\phi$  0.7 MAX / Recommendation tip shape : hemisphere

Note) Probe insertion over 3.3mm may make contacts bending or deformation.

And do not add force over 0.6N to contact point.

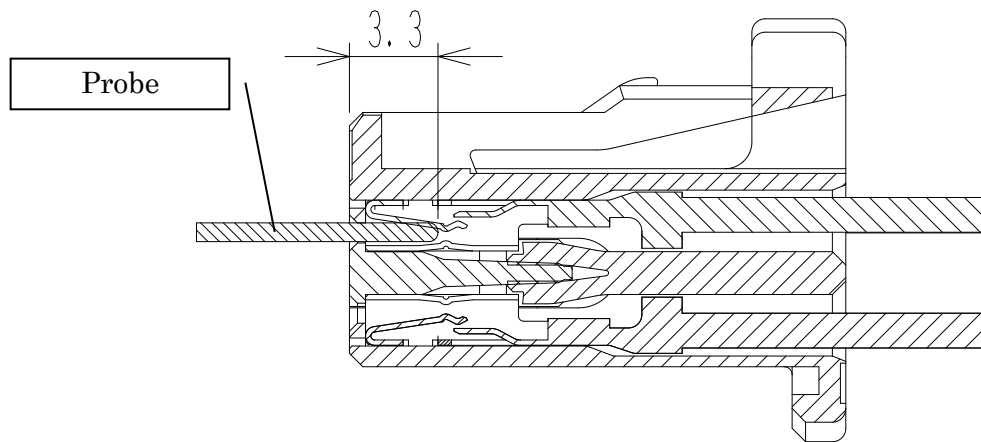

Assembled product section

## 5. Repair process

5-1. Unlock every housing locks by precision screwdriver and return the retainer to preset position.

Note) Change the housing if you deformed or broke the housing lock.

Bending locks over 0.85mm make products deforming.

We prepare protective jig from deforming at the request of customers.

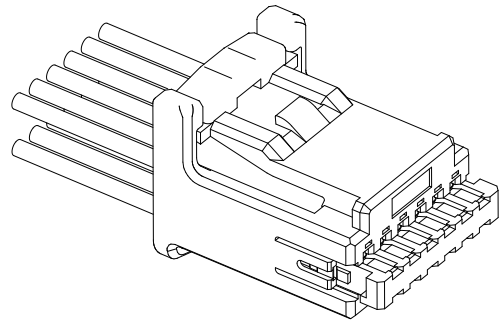
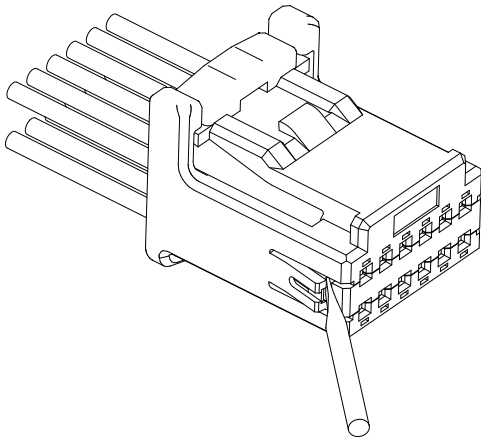

5-2. Pinch the retainer and pull it straight. You could come off the retainer from housing.

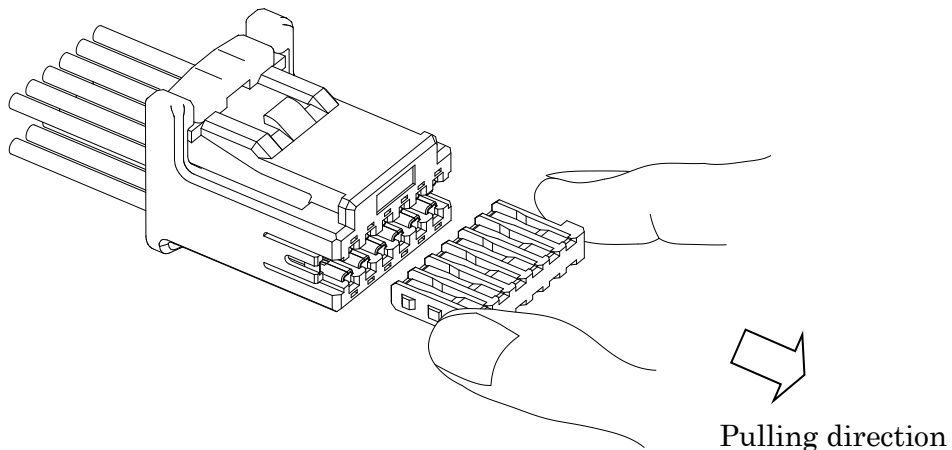

5-3. Insert specialized tool along the line of contact you want pull.

Note) General screwdriver is available to unlock the lance but work carefully to prevent contacts from scratch.

Don't recommend housing reuse, unless using our specialized tool.

Products name & No. of tool : GT25H/RE-MD (CL902-5114-3-00)

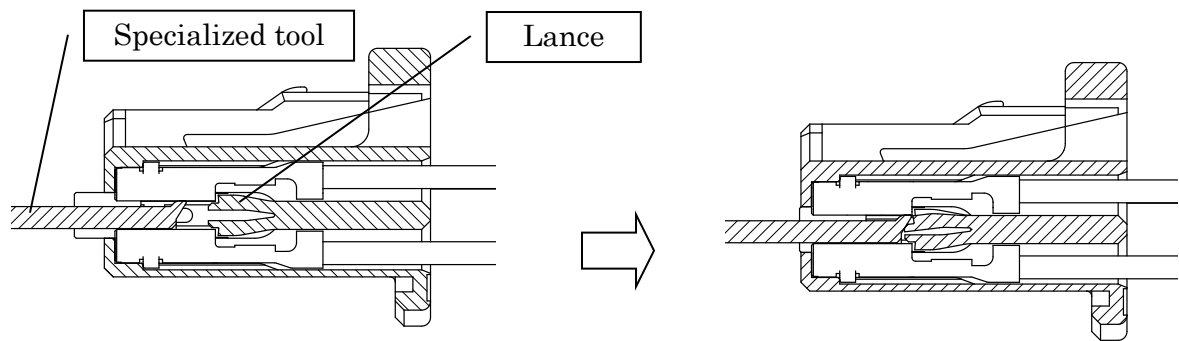

5-4. Keep the tool push and pull the contact.

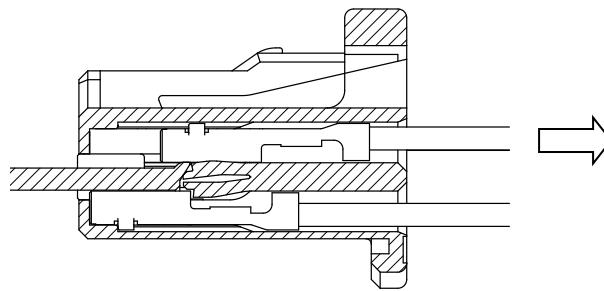



## 6. Connector mating method

6-1. Match the direction of male connector slit and female connector lock.

After that, mate connectors.

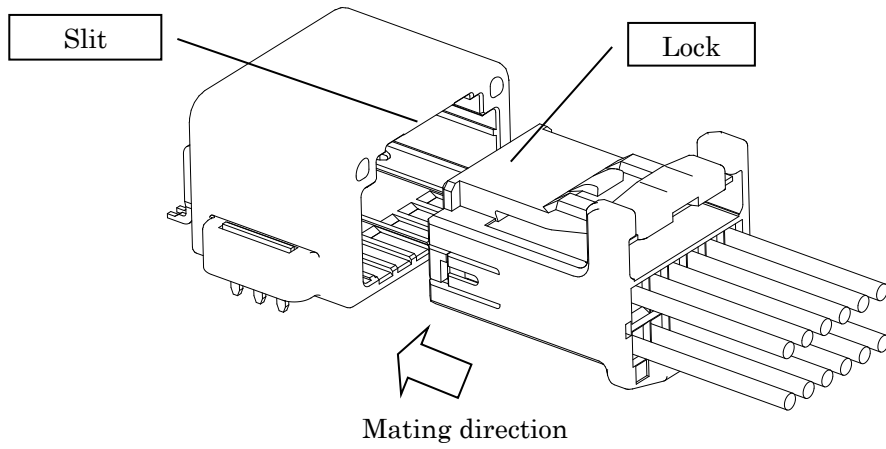

6-2. Insert the female connector until you feel the click.

Note) After mating, pull the female connector and check the connectors locked.

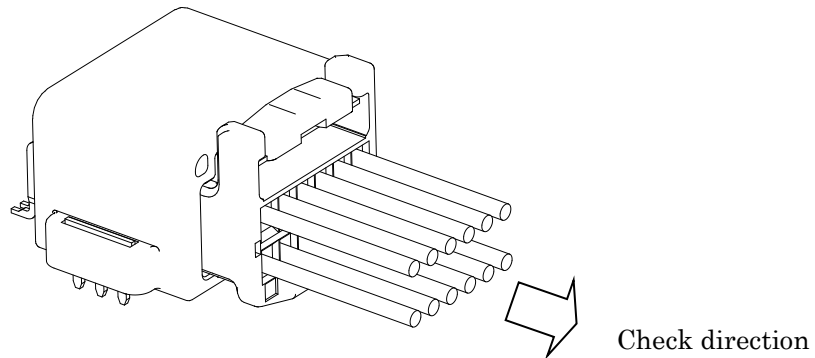

## 7. Connector un-mating method

7-1. While a female connector is kept at the mating end position, push the lock button

⚠ until the lock released.

Note) Touch the bottom of lock button to the housing.

Note) A lock function can not be released in case that the lock button is pushed at the female connector pulling position because there is not enough space for the moving lock as a lock is interfered by the male housing.

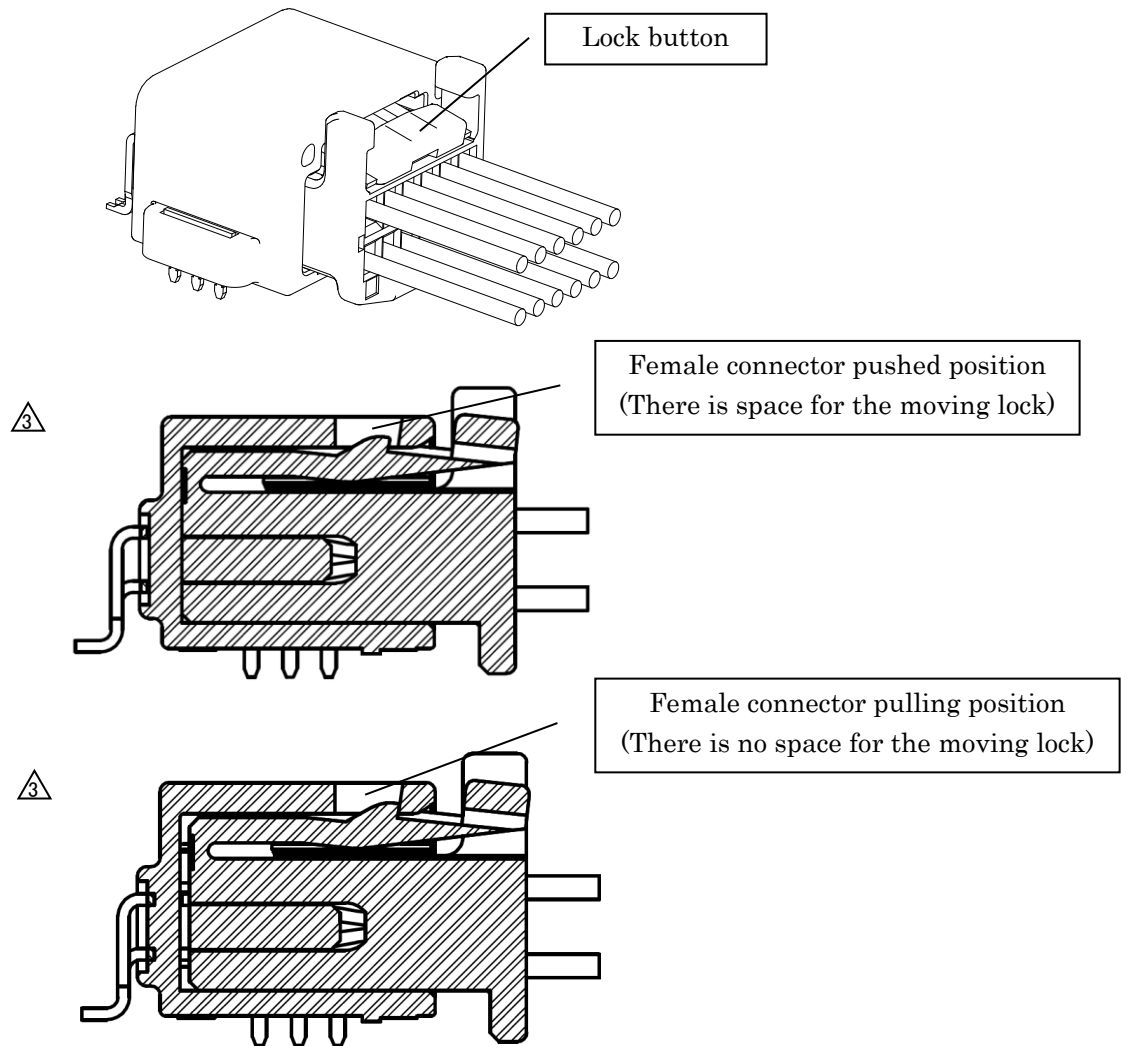

7-2. Pull the female connector straight.

Note) If you pull the female connector with incomplete lock release, you may break the connector or deform the contacts.

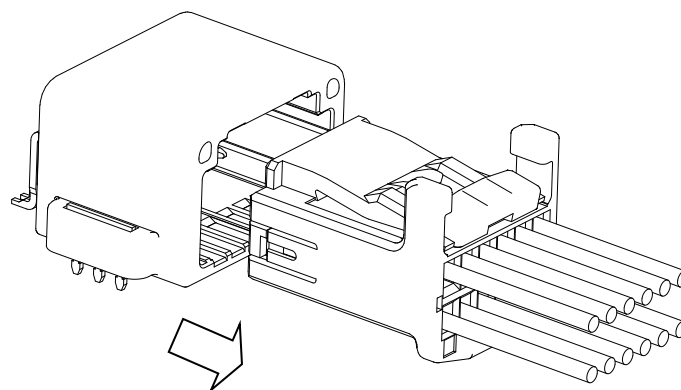

Pulling direction

## 8. Remarks

- (1) Do not touch the terminal point of contact and inside barrel.
- (2) To avoid contact deformity and adhesion of dirt, do not place anything on the contacts or drop the contacts.
- (3) If the contacts are caught each other, do not try to pull out roughly but loosen them carefully.
- (4) Pinch the contacts carefully to prevent them deforming.
- (5) Do not store contacts in dusty room.
- (6) Do not have an impact on the contacts.
- (7) Do not put the wire harness on the floor.
- (8) The connector is weak against impact, because do not throw it or swing it around.
- (9) Handle the connector and contacts carefully to prevent deforming or scratch.

## 9. Storing

Storage location	Temperature and humidity conditions	Maximum storage period
room	15~30°C, 60%Rh MAX	6 months (HRS packing condition)

In the case where an air-conditioned room is not applicable, following storage conditions avoided as practicably as possible exposure to dust and direct sunlight may be applied instead.

Storage location	Temperature and humidity conditions	Storage days
room	-30~60°C, 80%Rh MAX	6 months (HRS packing condition)