

Feb.1.2025 Copyright 2025 HIROSE ELECTRIC CO., LTD. All Rights Reserved.
 In case of consideration for using Automotive equipment / device which demand high reliability, kindly contact our sales window correspondents.

ELV, RoHS COMPLIANT

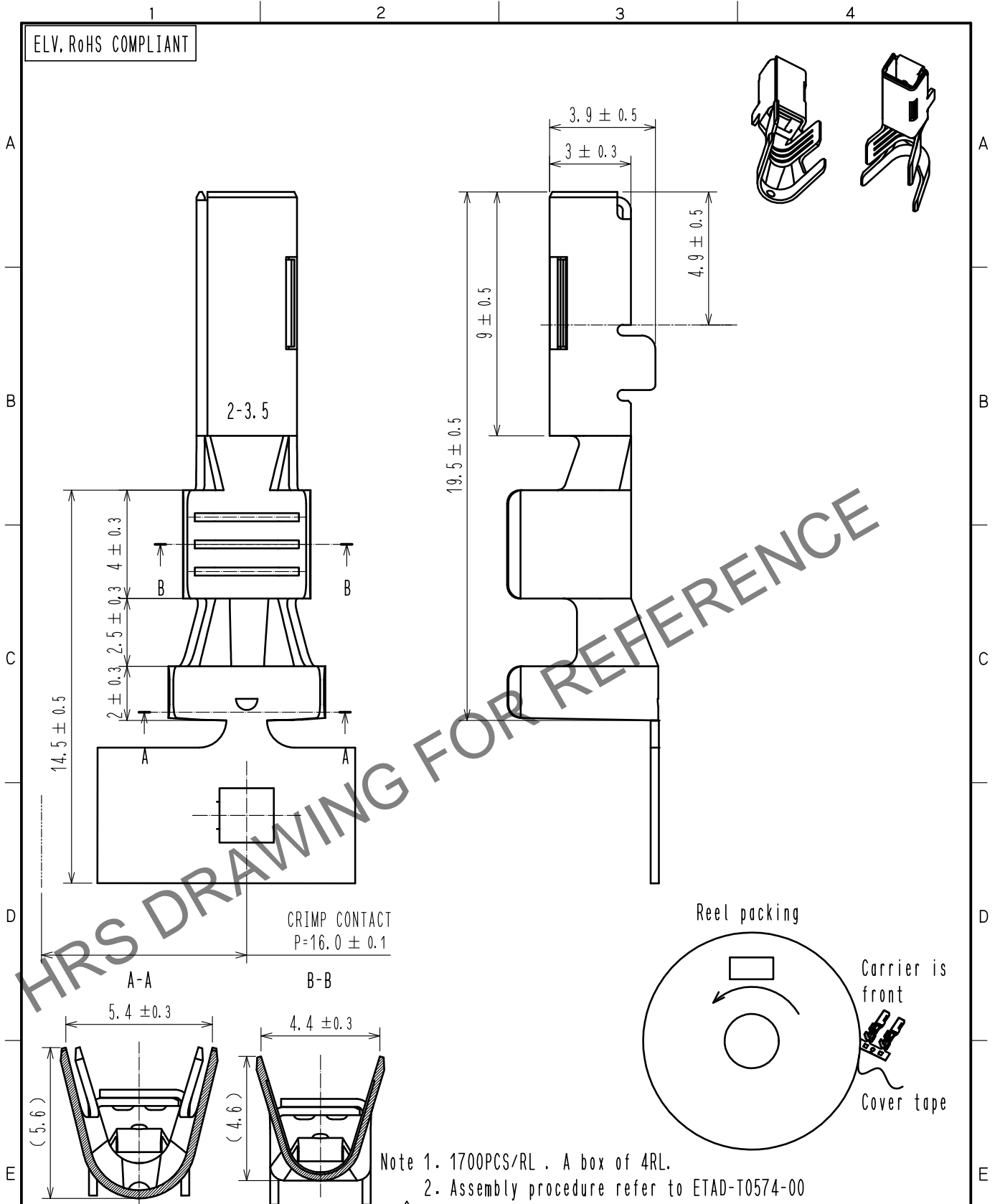

HRS DRAWING FOR REFERENCE

CRIMP CONTACT
 P=16.0 ± 0.1

Reel packing

Carrier is front
 REEL
 Cover tape

Note 1. 1700PCS/RL . A box of 4RL.
 2. Assembly procedure refer to ETAD-T0574-00
 ⚠ 3. REGARDING HOW TO HANDLE THE PACKAGED PRODUCTS.
 PLEASE REFER TO THE ATAD-T0946-00 INSTRUCTION MANUAL
 FOR HANDLING OF REEL PACKAGING CONTAINING CRIMP TERMINALS J

1	COPPER ALLOY	SURFACE:TIN PLATING 1 μm MIN UNDER PLATING NICKEL0.5 μm MIN						
NO.	MATERIAL	FINISH .	REMARKS	NO.	MATERIAL	FINISH .	REMARKS	
UNITS mm		SCALE 5 : 1	COUNT 1	DESCRIPTION OF REVISIONS DIS-T-00013628		DESIGNED AN. SAIKI	CHECKED HH. TSUKUMO	DATE 20220524
HRS HIROSE ELECTRIC CO., LTD.	APPROVED	HK. UMEHARA	20161128	DRAWING NO.	EDC-368756-00-00			
	CHECKED	HK. UMEHARA	20161128	PART NO.	HVH-280-1214SCF			
	DESIGNED	KO. NAKAMURA	20161128	CODE NO.	CL0778-0502-0-00			
	DRAWN	KO. NAKAMURA	20161128					