

Jan.1.2025 Copyright 2025 HIROSE ELECTRIC CO., LTD. All Rights Reserved.
In case of consideration for using Automotive equipment / device which demand high reliability, kindly contact our sales window correspondents.

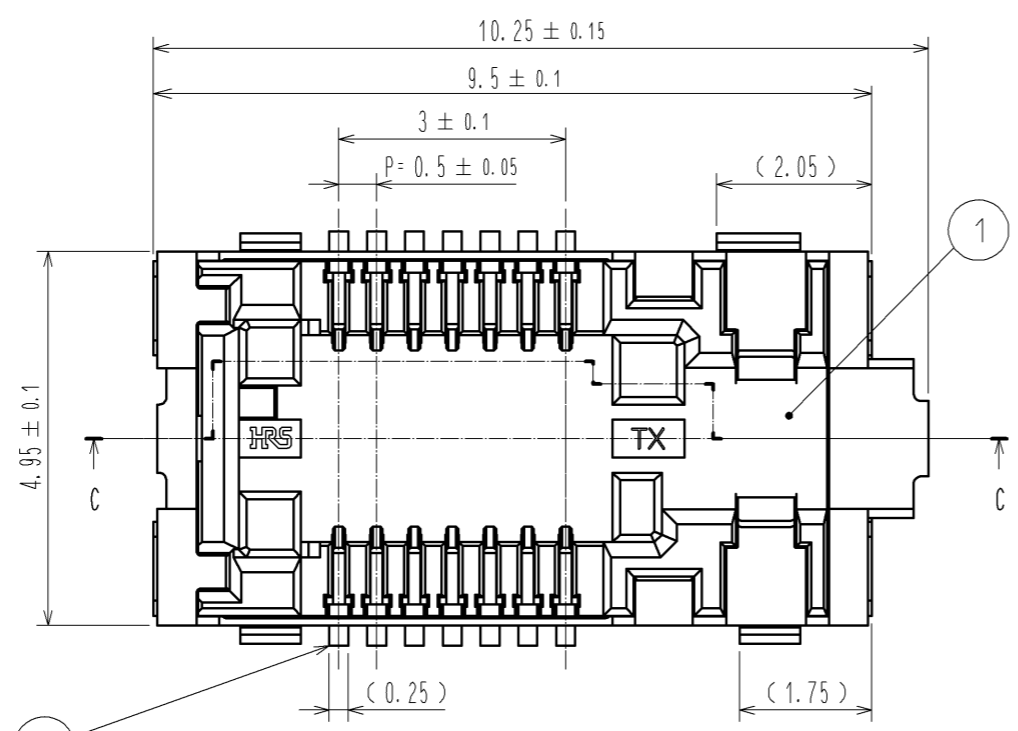

- NOTE. 1 All lead co-planarity shall be 0.1mm maximum.
- ② Contact plating
 - Contact area :Gold 0.05um MIN
 - SMT lead :Gold 0.05um MIN
 - Under plating:Nickel 1um MIN
 There shall be the nickel barrier between contact and SMT area.
 - ③ Shell plating
 - All area :Gold 0.05um MIN
 - Under plating:Nickel 1um MIN 2um MAX
 - 4 The peeling strength of cover tape shall comply with IEC 60286-3 (JIS C 0806-3).
 - 5 Embossed carrier tape has the sprocket hole on one side.
 - ⑥ Recommended land pattern is shown. Please do not arrange the via without resist in the hatching part as shown in the figure.
 - ⑦ The connector dimension when the plug engages is shown.
 - ⑧ Please note that it becomes impossible to use extraction tool when other parts are in the crossing hatching part as shown in the figure.
 - 9 Please layout the PCB pattern and fiber alignment, considering not to overload fiber. (Please see ETAD-K0398 about connector handling precautions.)
 - ⑩ Pin assignment and functions are described in the specification of BF4M plug connector (ETAD-K0485)

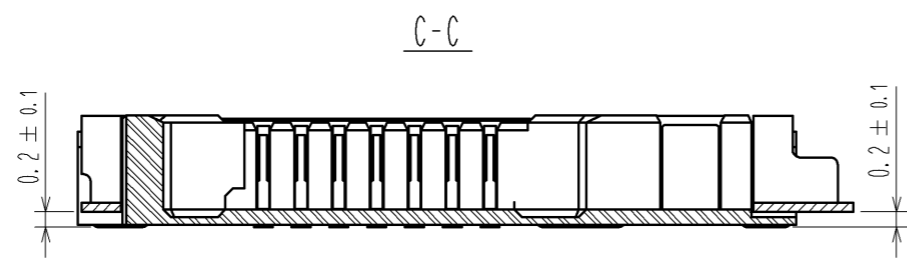
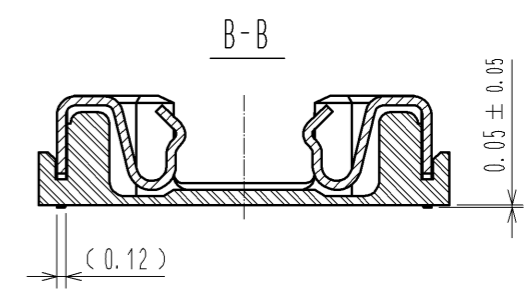
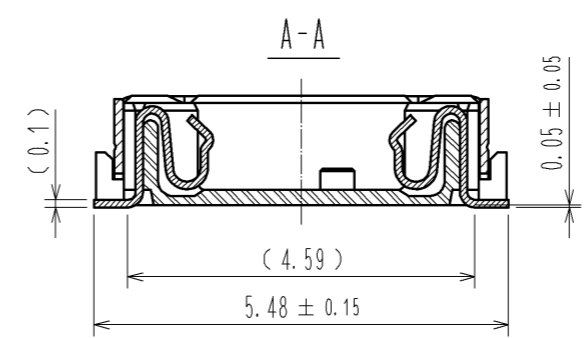
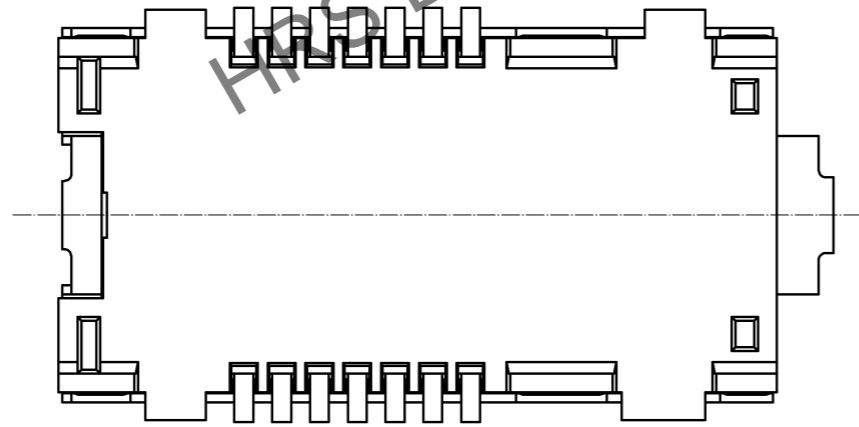
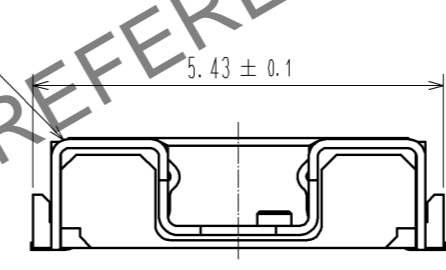
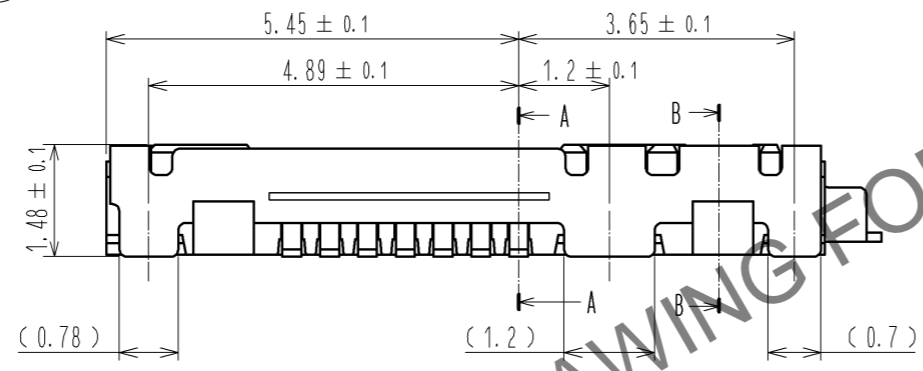
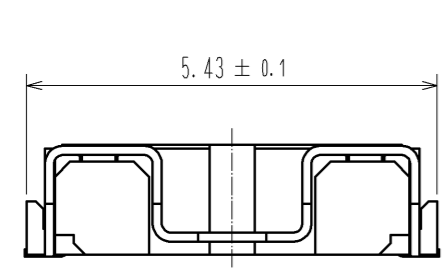

3	Phosphor Bronze	③	5	Polyester	Clear (Cover tape)
2	Phosphor Bronze	②	4	PS	Clear (Embossed carrier tape)
1	LCP	UL94 V-0			
NO.	MATERIAL	FINISH . REMARKS	NO.	MATERIAL	FINISH . REMARKS
UNITS	mm	SCALE	10 : 1	COUNT	4
DESCRIPTION OF REVISIONS			DESIGNED	CHECKED	DATE
DIS-K-002978			SJ. SUZUKI	SJ. SHIMIZU	13.06.27
APPROVED : MT. SHIBUTANI 13.03.01			DRAWING NO. EDC3-178303-10		
CHECKED : SJ. SHIMIZU 13.03.01			PART NO. BF4-TX-14DS-0.5V<10>		
DESIGNED : KS. JOKURA 13.02.28			CODE NO. CL831-0008-6-10		
DRAWN : KS. JOKURA 13.02.28			①/②		

Jan.1.2025 Copyright 2025 HIROSE ELECTRIC CO., LTD. All Rights Reserved.
In case of consideration for using Automotive equipment / device which demand high reliability, kindly contact our sales window correspondents.

Dimensions of embossed carrier tape (Scale : FREE)

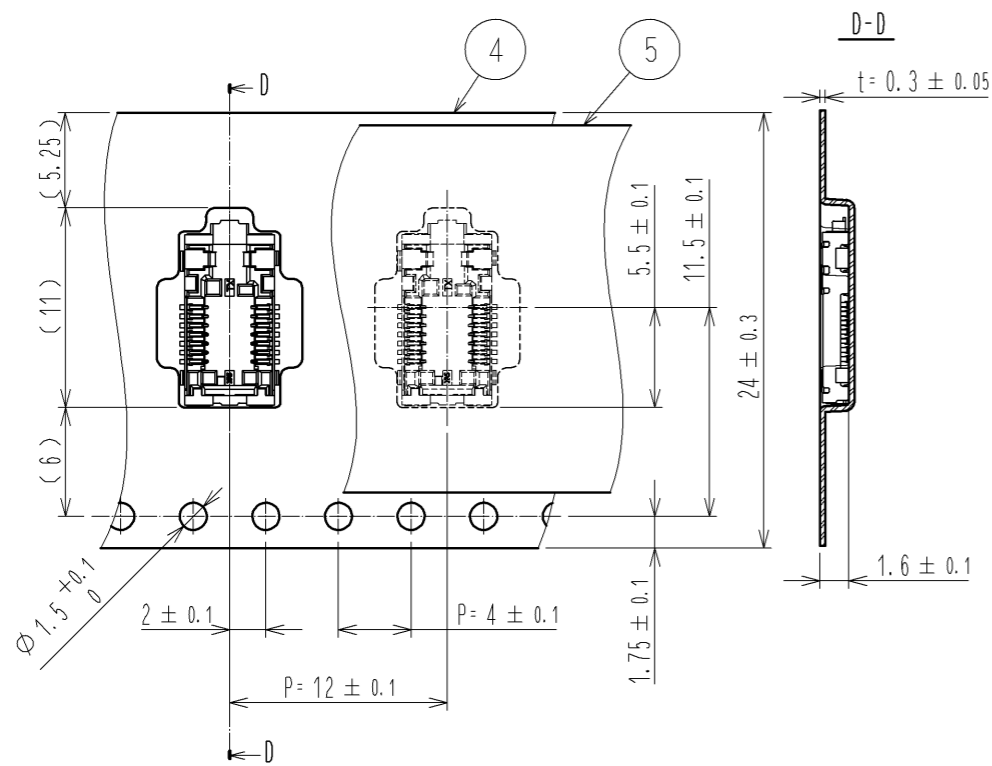

Packing style (Scale : FREE)

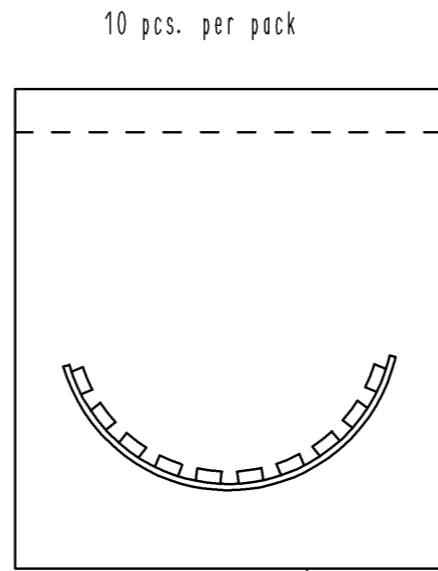

Recommended reflow temperature profile using Lead-Free solder paste.

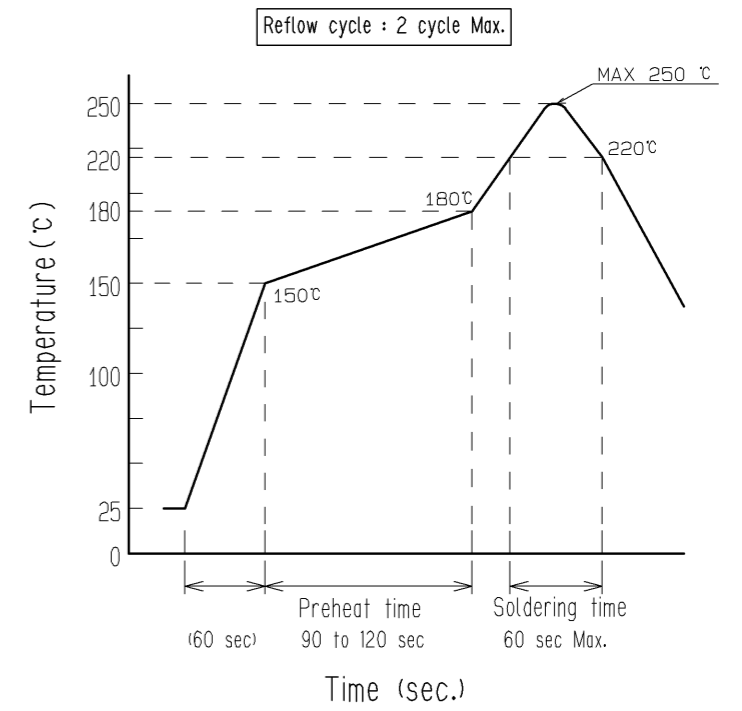

6 Recommended PCB land pattern

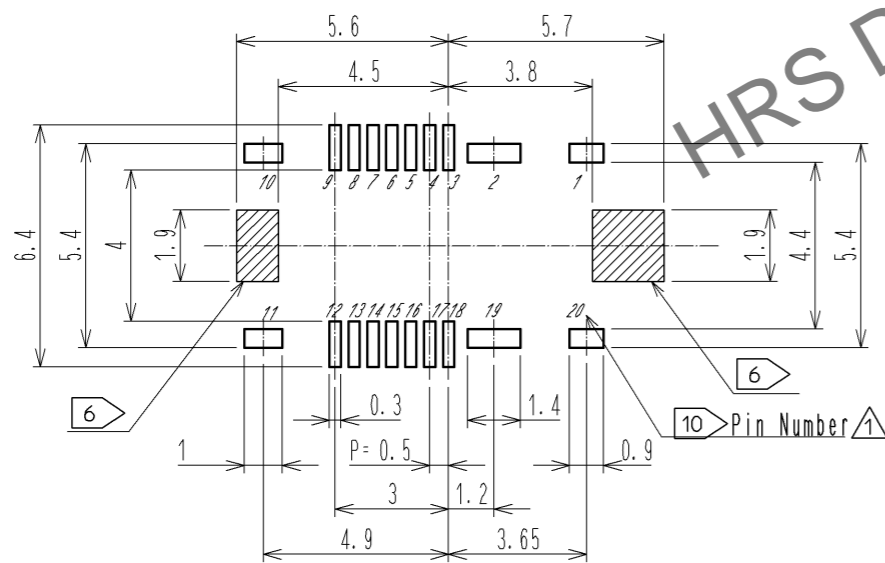

Recommended metal mask dimensions (Mask thickness : 120 μm)

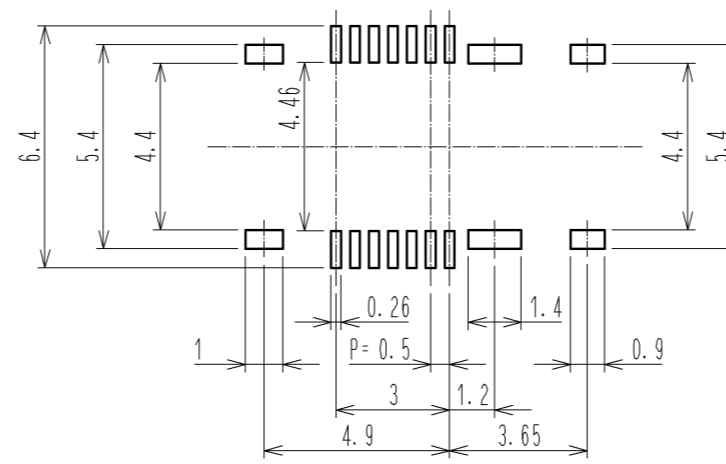

Aperture ratio
 Pads mounted contacts : 70%
 Pads mounted shell : 100%

7 Dimensions of engaged connector (Scale : FREE)

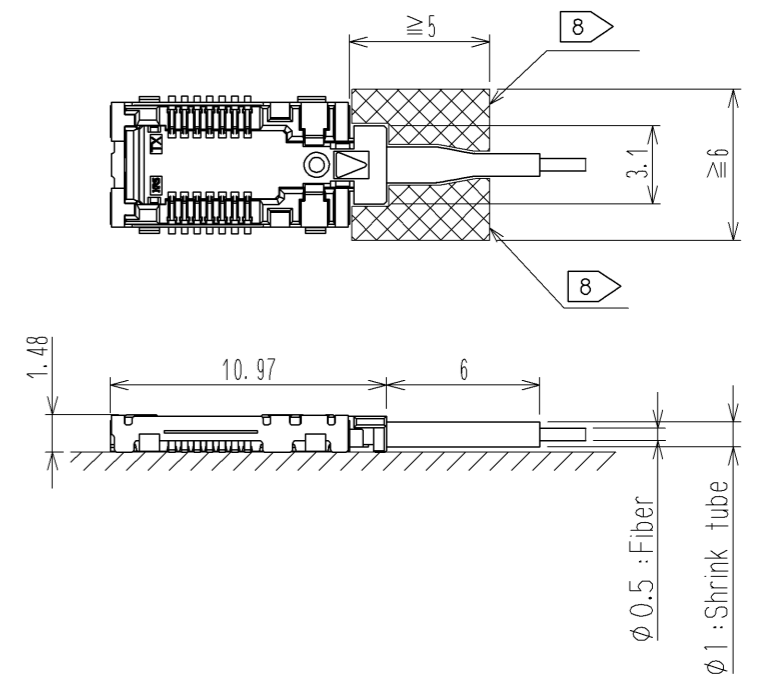

HRS	DRAWING NO.	EDC3-178303-10
	PART NO.	BF4-TX-14DS-0.5V(10)
	CODE NO.	CL831-0008-6-10
		$\frac{1}{2}$