

Jan.1.2025 Copyright 2025 HIROSE ELECTRIC CO., LTD. All Rights Reserved.
In case of consideration for using Automotive equipment / device which demand high reliability, kindly contact our sales window correspondents.

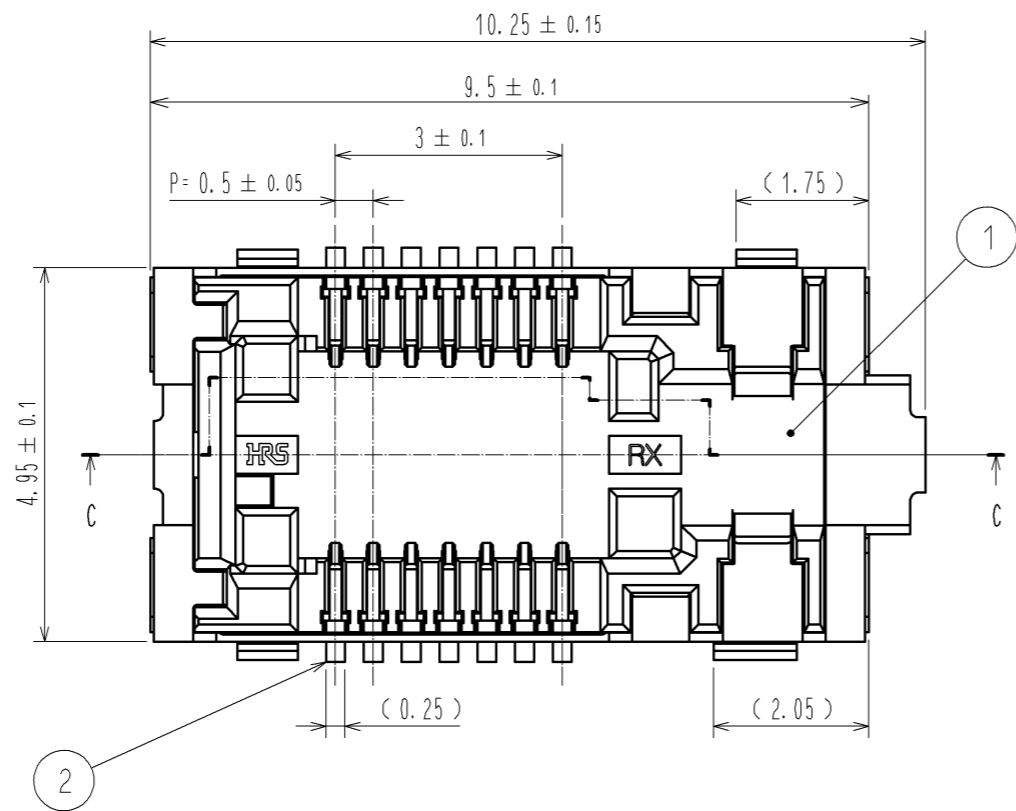

NOTE 1 All lead co-planarity shall be 0.1mm maximum.

- ② Contact plating
 - Contact area :Gold 0.05um MIN
 - SMT lead :Gold 0.05um MIN
 - Under plating:Nickel 1um MIN

There shall be the nickel barrier between contact and SMT area.
- ③ Shell plating
 - All area :Gold 0.05um MIN
 - Under plating:Nickel 1um MIN 2um MAX
- 4 The peeling strength of cover tape shall comply with IEC 60286-3 (JIS C0806-3).
- 5 Embossed carrier tape has the sprocket hole on one side.
- ⑥ Recommended land pattern is shown. Please do not arrange the via without resist in the hatching part as shown in the figure.
- ⑦ The connector dimension when the plug engages is shown.
- ⑧ Please note that it becomes impossible to use standard extraction tool (BF4-T1) when other parts are in the crossing hatching part as shown in the figure.
- 9 Please layout the PCB pattern and fiber alignment, considering not to overload fiber. (Please see ETAD-K0398 about connector handling precautions.)
- ⑩ Pin assignment and functions are described in the specification of BF4M plug connector (ETAD-K0485)
- ⑪ Please see drawing EDC3-178304-10 for 10pcs packing product BF4-RX-14DS-0.5V(10).

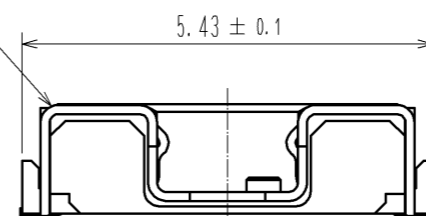
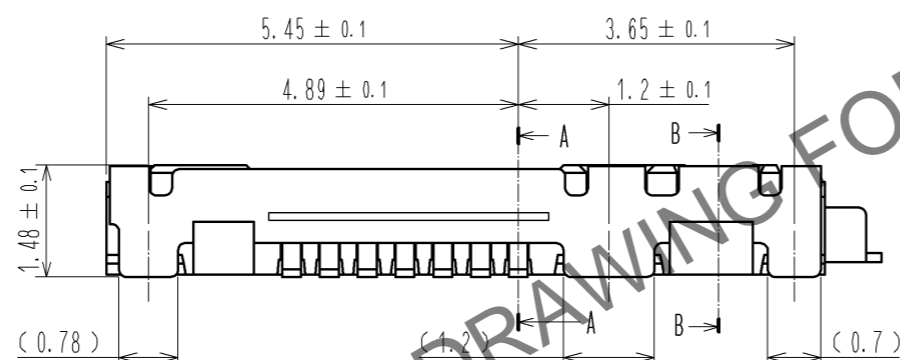
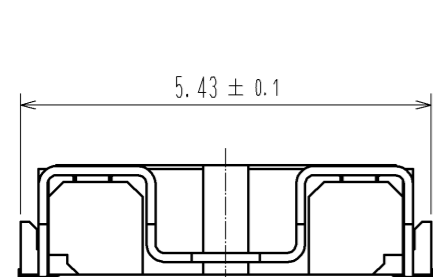

Part No. & Code No. corresponding to the quantity

Quantity	Part No.	Code No.
500 pcs.	BF4-RX-14DS-0.5V	CL0831-0009-9-00
1,000 pcs.	BF4-RX-14DS-0.5V(01)	CL0831-0009-9-01
2,000 pcs.	BF4-RX-14DS-0.5V(02)	CL0831-0009-9-02
10 pcs.	BF4-RX-14DS-0.5V(10)	CL0831-0009-9-10
100 pcs.	BF4-RX-14DS-0.5V(11)	CL0831-0009-9-11

A-A

B-B

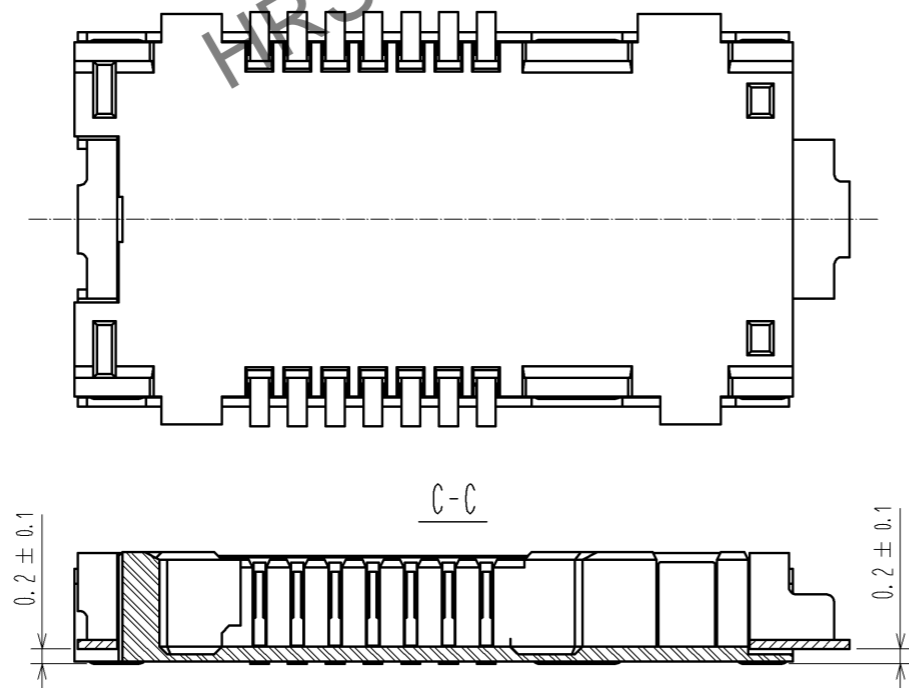
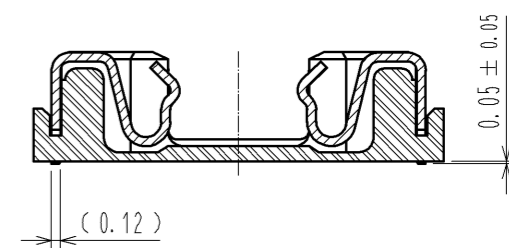
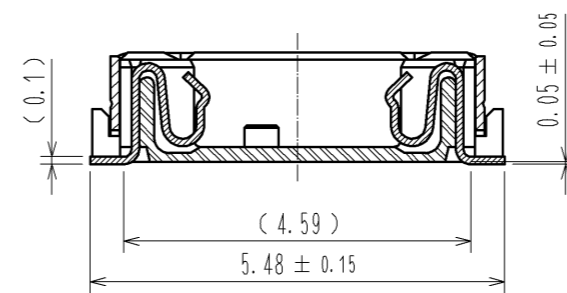

3	Phosphor Bronze	③	6	PS	BLACK (Plastic reel)
2	Phosphor Bronze	②	5	POLYESTER	CLEAR (Cover tape)
1	LCP	UL94 V-0	4	PS	CLEAR (Embossed carrier tape)
NO.	MATERIAL	FINISH . REMARKS	NO.	MATERIAL	FINISH . REMARKS
UNITS	mm	SCALE	10 : 1	COUNT	1
DESCRIPTION OF REVISIONS			DESIGNED	CHECKED	DATE
DIS-K-003044			KS. JOKURA	SJ. SHIMIZU	13.08.23
APPROVED : MT. SHIBUTANI			12.11.15		
CHECKED : SJ. SHIMIZU			12.11.15		
DESIGNED : KS. JOKURA			12.11.15		
DRAWN : KS. JOKURA			12.11.15		
DRAWING NO.			EDC3-178302-00		
PART NO.			BF4-RX-14DS-0.5V(**)		
CODE NO.					

Jan.1.2025 Copyright 2025 HIROSE ELECTRIC CO., LTD. All Rights Reserved.
In case of consideration for using Automotive equipment / device which demand high reliability, kindly contact our sales window correspondents.

Dimensions of embossed carrier tape (Scale : FREE)

Packing reel (Scale : FREE)

Recommended reflow temperature profile using Lead-Free solder paste.

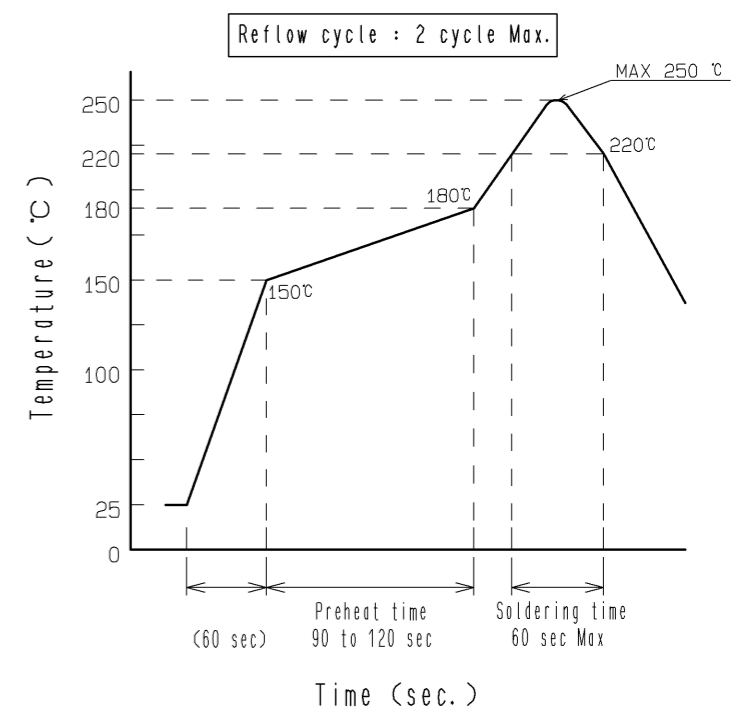
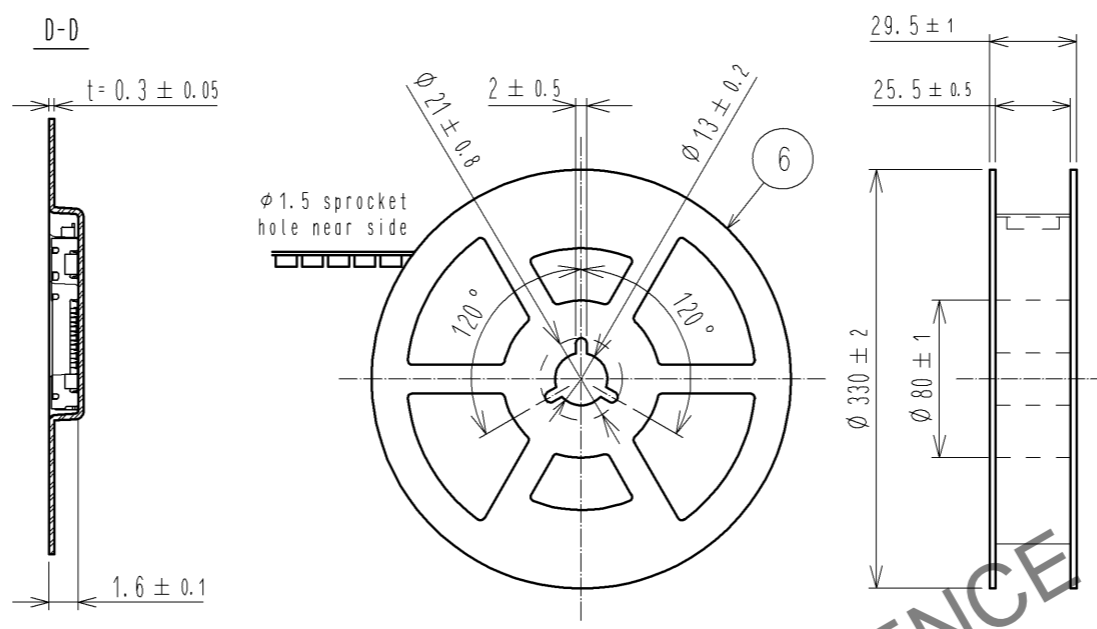
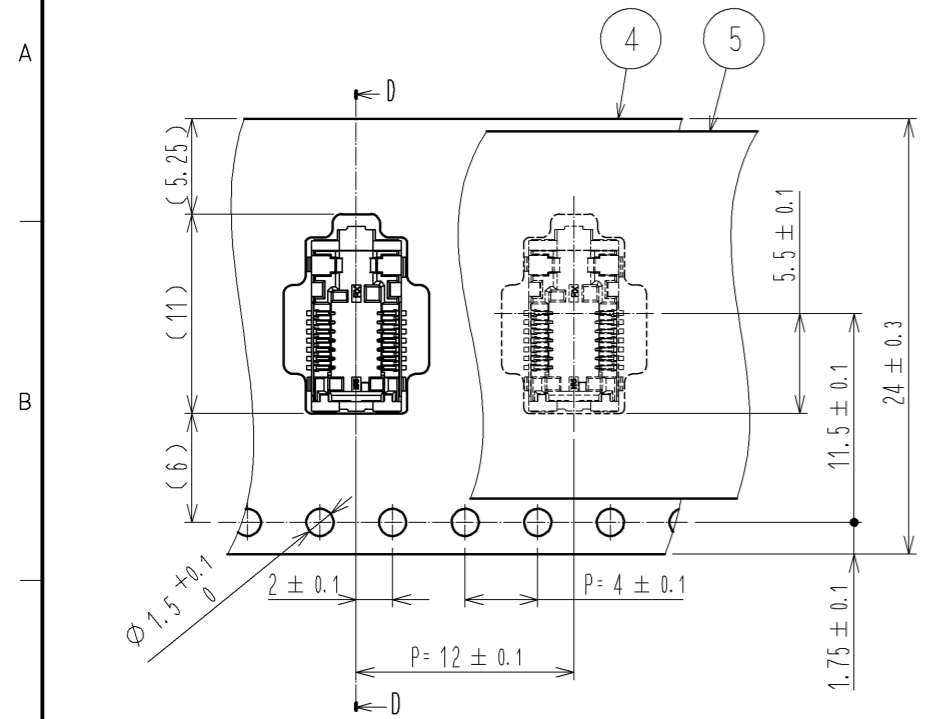

Taping direction (Scale : FREE)

Dimensions of engaged connector (Scale:FREE)

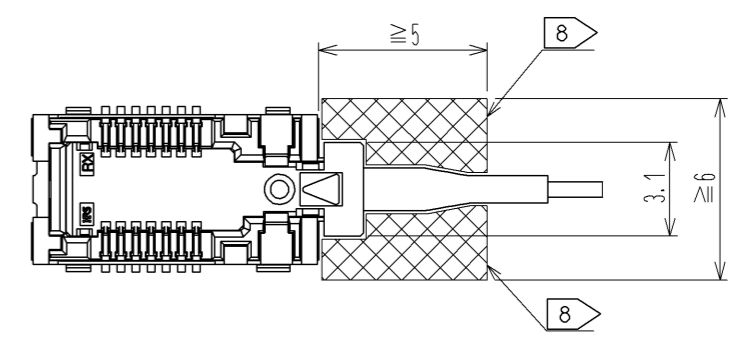
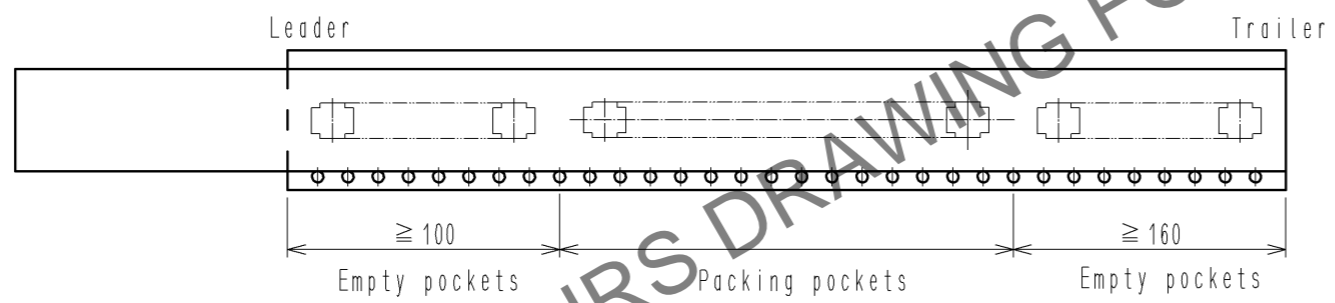

Recommended PCB land pattern

Recommended metal mask dimensions (Mask thickness : 120 μm)

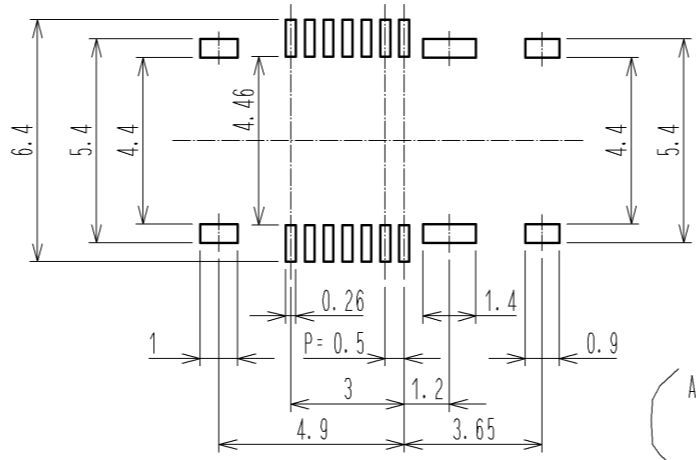
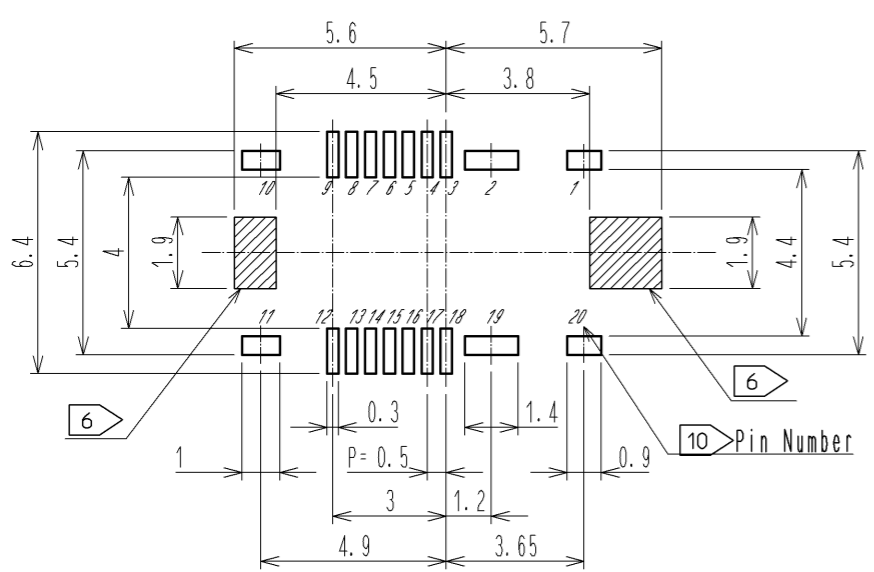
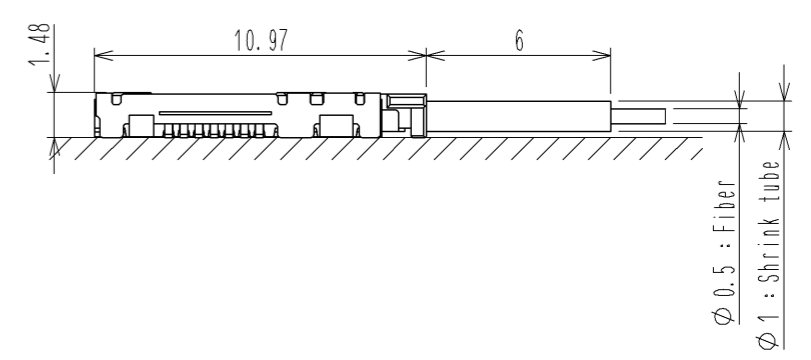

Aperture ratio
 Pads mounted contacts : 70%
 Pads mounted shell : 100%

HRS	DRAWING NO.	EDC3-178302-00
	PART NO.	BF4-RX-14DS-0.5V(**)
	CODE NO.	