

Desk cable connection jig

Model DF19G SERIES

HRS®

Applicable cable connection jig main units

DF19G-14S/PR-MD2

DF19G-20S/PR-MD2

DF19G-30S/PR-MD2

INSTRUCTION MANUAL



CAUTION :

Be sure to read this Instruction Manual carefully before using it to secure safety in operation. In addition, save this Instruction Manual so that it is available whenever necessary for review.

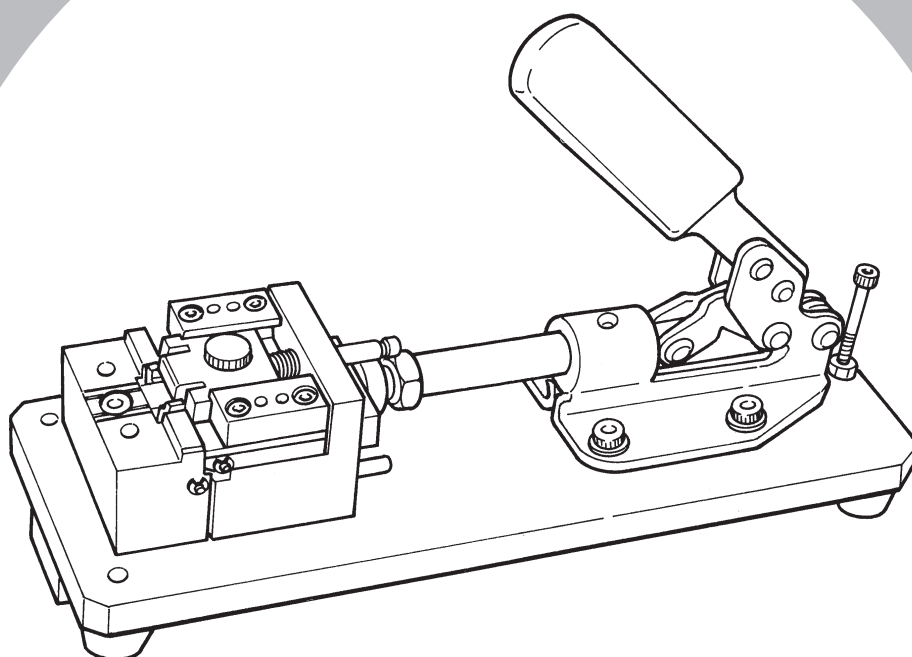



HIROSE ELECTRIC CO., LTD.

For safe operation

The operators of the tool and the maintenance personnel who are in charge of maintenance and repair work are required to read the following **SAFETY INSTRUCTIONS** so as to avoid injury.

Fully understand the descriptions given in this Instruction Manual and the warning labels attached on the tool, and follow the instructions.

(I) Description of warning messages

 DANGER	Used in the case where it is assumed that misuse of the machine will expose the operator to immediate danger of major injury or death.
 WARNING	Used in the case where it is assumed that misuse of the machine can expose the operator to danger of major injury or death.
 CAUTION	Used in the case where it is assumed that misuse of the machine can expose the operator to danger of injury and can cause damage to property.

* Determine the degree of impairment referring to the below-stated classification.

Major injury : Indicates the loss of eyesight, wounds, burns (hyperthermal and hypothermal burns), electric shocks, fracture of a bone, poisoning, etc. requiring emergency of extended medical care.

Injury (Minor injury) : Indicates wounds, burns, electric shocks, etc. requiring medical treatment.

Damage to property : Indicates damage to the machinery and or the surrounding area.

SAFETY INSTRUCTIONS



CAUTION

Basic safety instructions

1. Be sure to read this Instruction Manual and all the instructions and other materials supplied with the unit as accessories. Save this Instruction Manual and make it available for review whenever necessary.
2. To prevent possible personal accidents, perform operation so that your fingers or the like are not caught in the handle. In addition, use this machine putting on a place where children's hands cannot reach.

Application and modification

1. To prevent possible personal accidents, this tool shall only be used for its originally intended purpose while following the instructions specified in this Instruction Manual. We assume no responsibility resulting from the use other than the application.
2. To prevent possible personal accidents, modification to this tool is prohibited. We assume no responsibility resulting from the modifications.

Training

1. To prevent possible accidents caused by unfamiliarity with the operation of the tool, the tool shall only be allowed to be used by the operators who have been trained for proper operation and provided with sufficient knowledge of safe operation by the employee.

When operating

1. To prevent possible personal accidents, be careful so that fingers or the like are not caught in the handle or the crimping section when crimping with this unit.
2. To prevent possible electric shock accidents, turn off the power to the machine or unit and use this crimping machine when replacing or installing the terminal or contact in a state that the machine or unit is wired.

Maintenance

1. To prevent possible accidents caused by unfamiliarity with the operation of the tool, repair and adjustment of the tool shall be conducted only by maintenance personnel who have a full knowledge of the tool. Use our genuine parts when replacing parts. We assume no responsibility for accidents caused by improper repair or adjustment or the use of non-genuine part(s).
2. To prevent possible personal accidents, be sure to wipe off anticorrosive oil applied to the tool, or oil or water adhered to the tool during operation before starting operation.

CONTENTS

I. Specifications and configuration	1
1. Specifications	1
2. Applicable product and model	1
3. Commendable standard of FPC dimensions	1
4. Configuration of desk jig components.....	2
5. Configuration of connector components	2
II. Checking items before operation	3
III. Operating procedure	4
1. Mounting the ground plate.....	4
2. Inserting FPC	4
3. Preliminary insertion of the ground plate.....	5
4. Setting procedure of the connector.....	6
5. Connection work	7
6. Appearance inspection	8
7. Electrical test	8
IV. Repairing procedure in case of failure of connection	9
V. Precautions in handling the jig.....	10
VI. Maintenance and inspection	10

I. Specifications and configuration

1. Specifications

Item	Specifications
Function	Desk cable connection jig
Dimensions	230(W) × 117(H) × 80(D)
Weight	Approx. 3 kg

2. Applicable product and model

Applicable product	Product number		
Connector	DF19G-14S-1F	DF19G-20S-1F	DF19G-30S-1F
Ground plate	DF19G-14S-1F-GND	DF19G-20S-1F-GND	DF19G-30S-1F-GND
Jig	DF19G-14S/PR-MD2	DF19G-20S/PR-MD2	DF19G-30S/PR-MD2

3. Commendable standard of FPC dimensions

Dimensions described below denote the standard of FPC dimensions which can be mounted on this jig.



For the detailed dimensions, please contact our engineering division.

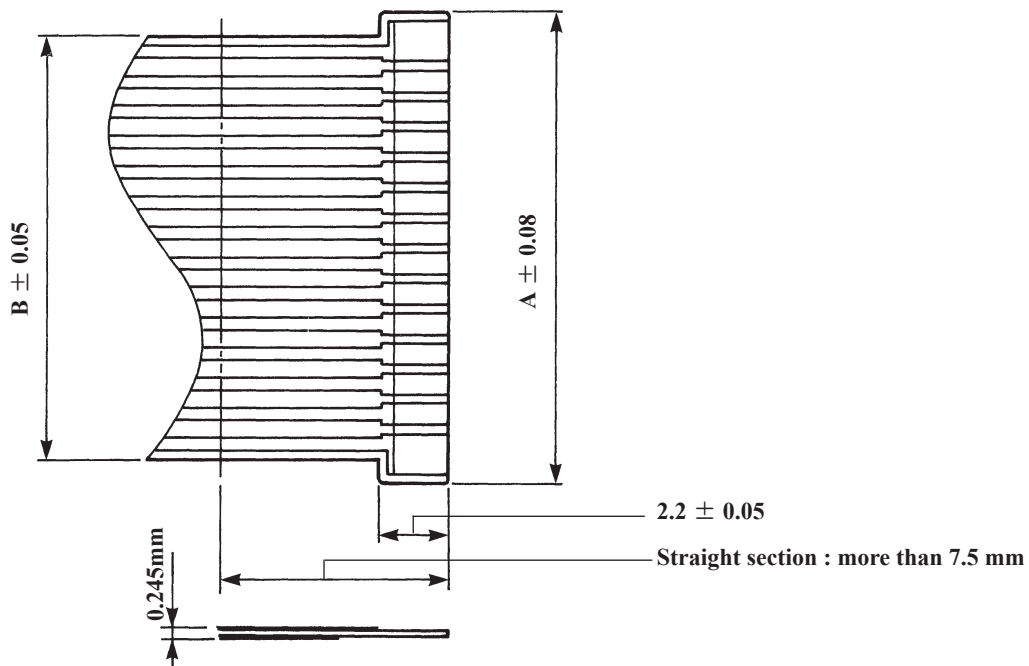

Name of connector	Dimension (mm)	
	A	B
DF19G-14S-1F	15.6	14
DF19G-20S-1F	21.6	20
DF19G-30S-1F	31.6	30

4. Configuration of desk jig components

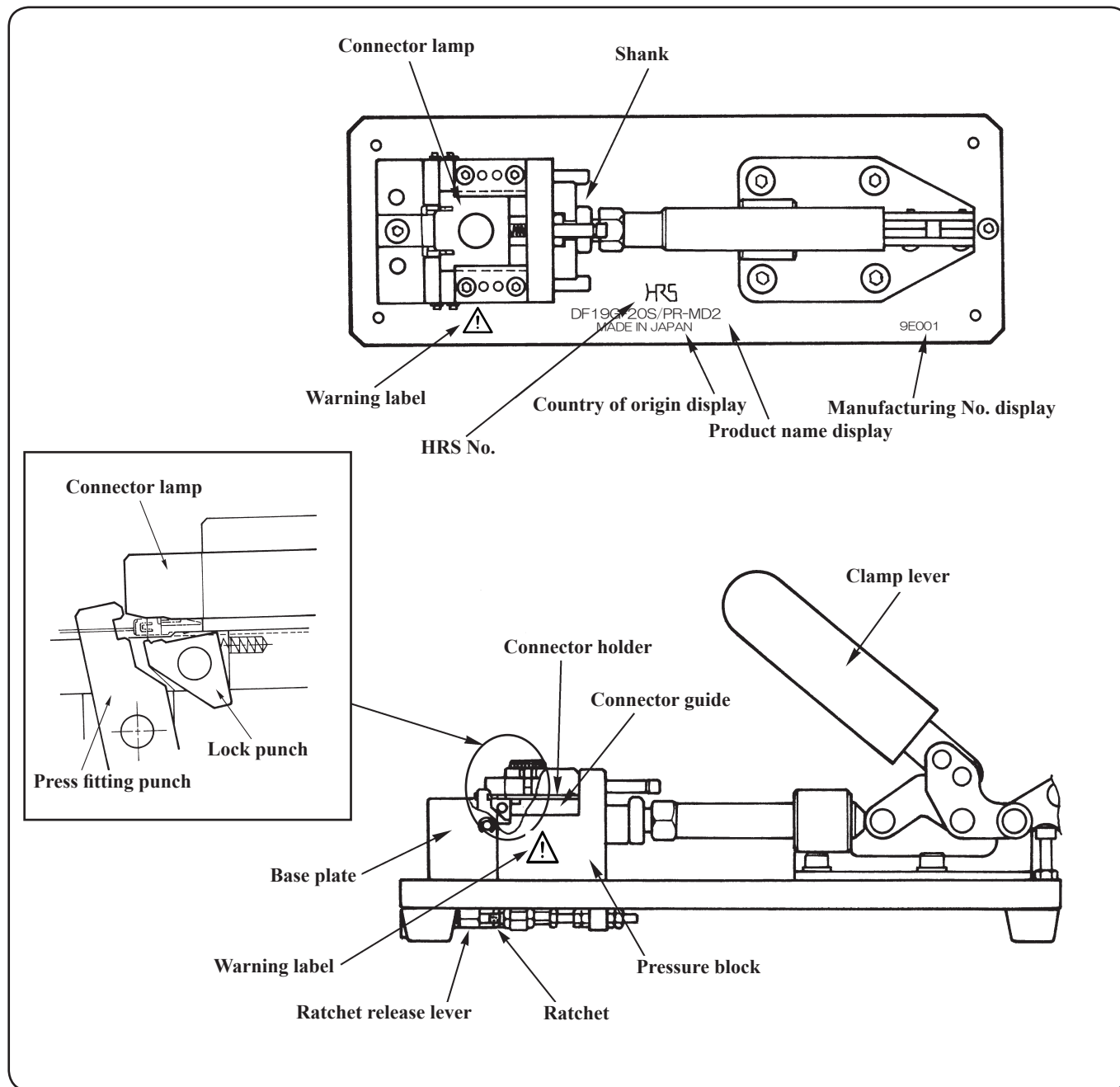

5. Configuration of connector components

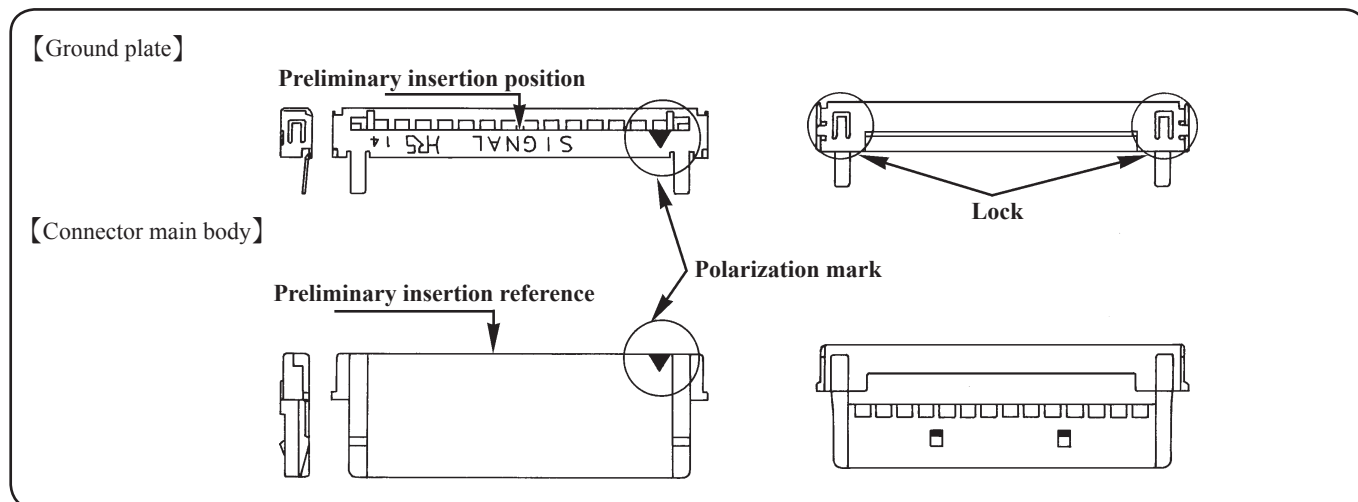

II. Checking items before operation



WARNING :

To prevent personal accidents, extreme caution has to be taken not to allow fingers to be caught in the handle or sliding parts when crimping with this tool.

No.	Checking item	Checking procedure	In case of trouble	Cause	Corrective measure
1	Clamp lever	<ul style="list-style-type: none"> Check whether there is a clamp feeling when clamp lever is fully pressed until it will go no further. 	<ul style="list-style-type: none"> Shut-height is improper and connection is not correctly performed. 	<ul style="list-style-type: none"> Shank installing position is improper. 	<ul style="list-style-type: none"> Please request us for repair.
2	Ratchet release	<ul style="list-style-type: none"> Check whether ratchet is released in the state that pressure block comes closely in contact with base plate face. 	<ul style="list-style-type: none"> Shut-height is improper and connection is not correctly performed. 	<ul style="list-style-type: none"> Ratchet installing position is improper. 	<ul style="list-style-type: none"> Ditto
3	Open/close press fitting punch and lock punch	<ul style="list-style-type: none"> Check that pressure block comes closely in contact with base plate face and each punch is smoothly opened without friction after clamp lever has been released. 	<ul style="list-style-type: none"> Shut-height is improper and connection is not correctly performed when pressure block does not come closely in contact with base plate face. 	<ul style="list-style-type: none"> Deformation of each punch. Mixture of foreign materials in sliding parts. Trouble of shut-height or the like. 	<ul style="list-style-type: none"> Ditto Completely remove foreign materials. Please request us for repair.
4	Deformation or breakage of press fitting punch and lock punch	<ul style="list-style-type: none"> Check through eye-observation whether each punch has neither deformation nor breakage. Perform an appearance inspection with the first connection product. 	<ul style="list-style-type: none"> Connection is not correctly performed when press fitting punch or lock punch is deformed or broken. 	<ul style="list-style-type: none"> Mixture of foreign materials in sliding parts. Mixture of foreign materials in clamp or the like. 	<ul style="list-style-type: none"> In case of deformation or breakage do not continue to use the jig. Please request us for repair.
5	Setting position of connector clamp	<ul style="list-style-type: none"> Check whether connector clamp comes in contact with set position when clamp lever is fully pressed until it will go no further. 	<ul style="list-style-type: none"> Connection is not correctly performed when connector lamp does not come in contact with set position. 	<ul style="list-style-type: none"> Mixture of foreign materials in sliding parts. Trouble of shut-height or the like. 	<ul style="list-style-type: none"> Ditto Ditto
6	Installation state of components	<ul style="list-style-type: none"> Check through eye-observation whether there is no lack or breakage of the respective components. 	<ul style="list-style-type: none"> Connection is not correctly performed. 		<ul style="list-style-type: none"> Ditto



If the jig is defective, do not perform disassembling or the like. Please contact us for repair.

III. Operating procedure

1. Mounting the ground plate

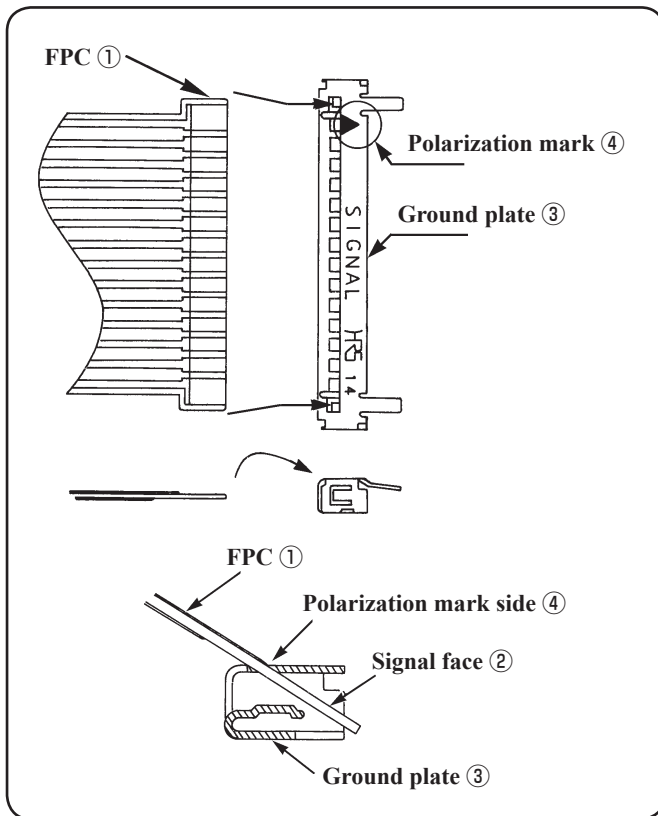

- 1) Face upward signal face ② of FPC ① and polarization mark ④ of the ground plate ③.
- 2) Mount the ground plate ③ so that you do not touch signal section ② of FPC by hand.



Adjust the direction of FPC referring to polarization mark "▶" of the ground plate.

2. Inserting FPC

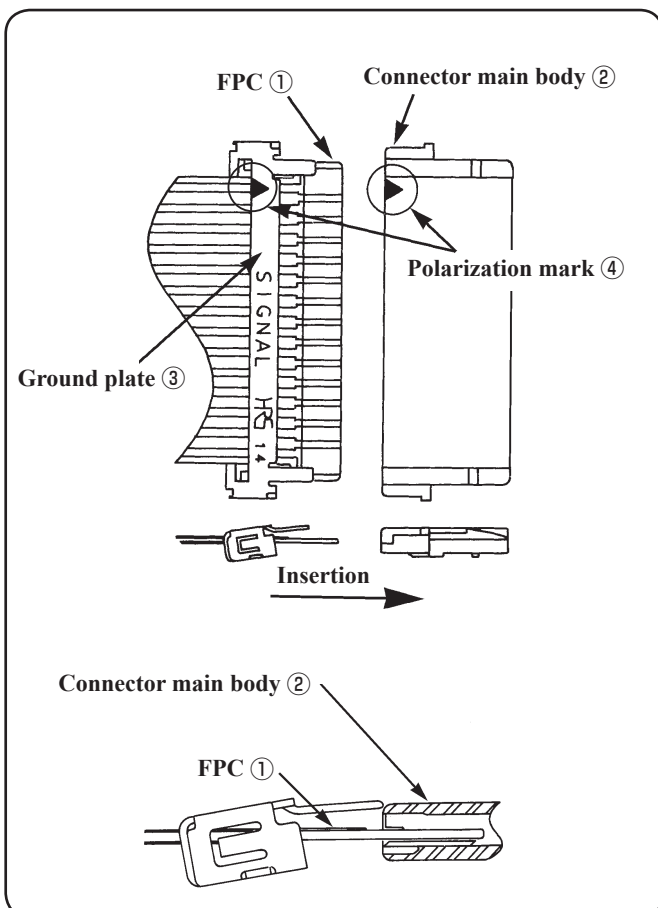

- 1) Adjust connector main body ② and polarization mark ④ of the ground plate ③ to the same direction.
- 2) Insert FPC ① until it comes in contact with the inside of connector main body ②.



Cautions when inserting FPC

1. The connector main body and the ground plate will be broken at the time of connection unless the connector main body and the polarization mark of the ground plate are set in the same direction.
2. Insertion may be difficult when FPC is warped.

3. Preliminary insertion of the ground plate

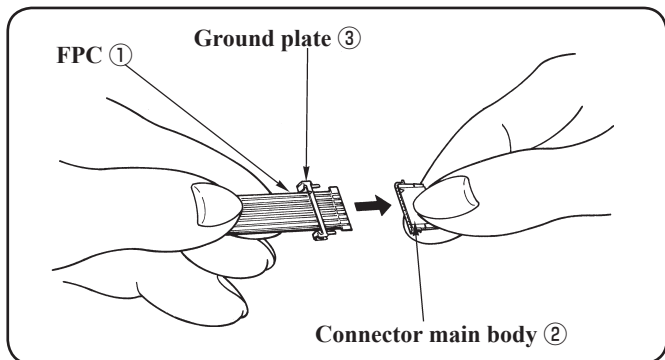

1) Making FPC ① come in contact with the inside of connector main body ②, insert ground plate ③ into the connector main body.

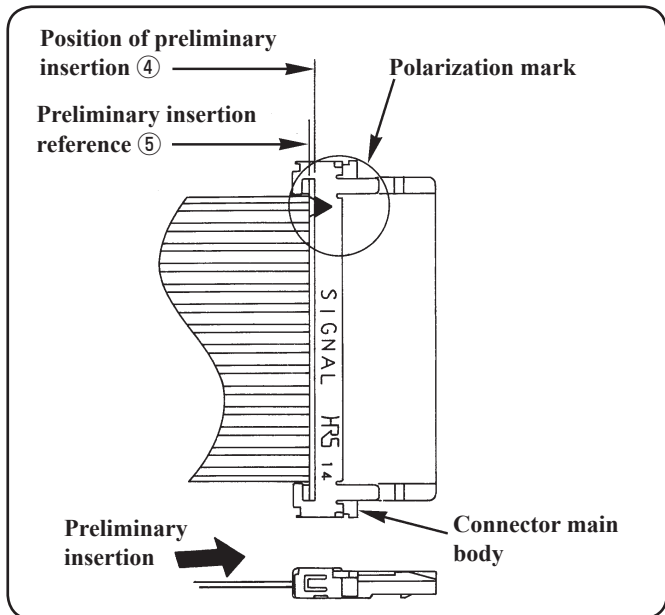

2) Insert the ground plate so that preliminary insertion position ④ comes in front of preliminary insertion reference ⑤ of the connector main body.



Cautions when inserting the ground plate

1. Do not use a ground plate which has been excessively warped at the time of preliminary insertion.
2. When the directions of FPC and polarization mark are reverse each other, perform the work from the first step without performing the preliminary insertion.
3. After completion of preliminary insertion, do not pull the FPC since the ground plate may come off.

● Preliminary insertion quality standard



Check to be sure that the component that has been inserted satisfies the following quality standards.

- A (OK) : Angle when the ground plate is inserted into the connector main body should be less than 10 degrees.
 B (NG) : Ground plate is slantingly inserted. Deformation of the ground plate will be caused.
 C (NG) : Lower click of the ground plate is widened. rise of the ground plate occurs when setting the connector.

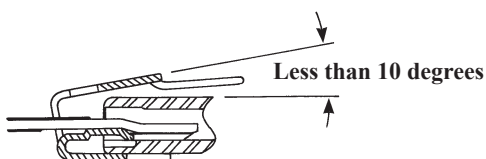

A:OK

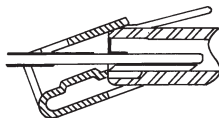

B:NG

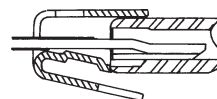

C:NG

4. Setting procedure of the connector

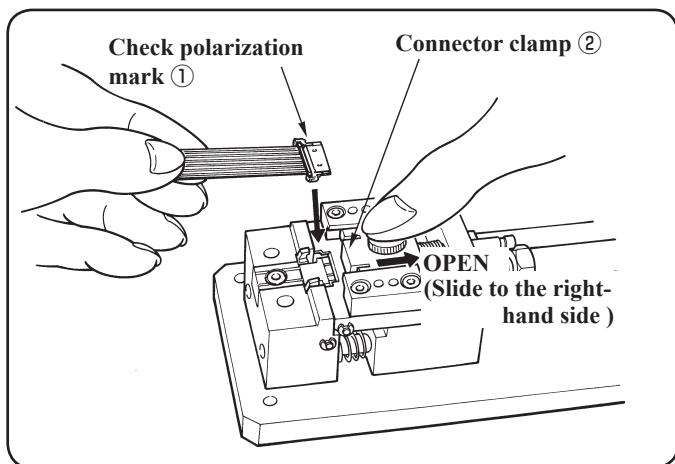

- 1) Face upward polarization mark side ① and slide connector clamp ② to the right-hand side to open it.

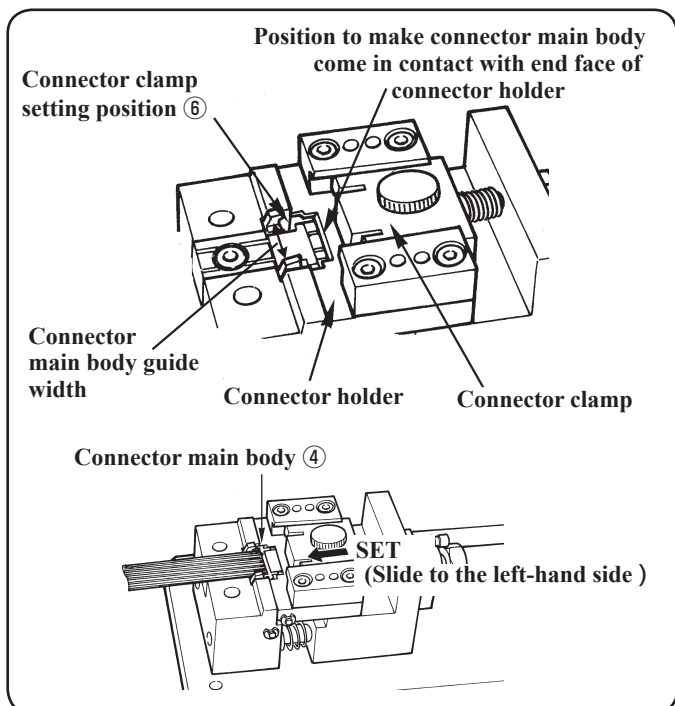

- 2) Adjust connector main body ④ to connector guide face ⑥ of connector holder ⑤ .
- 3) Making the connector main body come in contact with end face of the connector holder, slide connector clamp ⑦ to the left-hand side to close it.



When the connector clamp is caught on the ground plate and not closed by the spring force alone, lightly press the connector clamp by fingers up to the set position.



Connector clamp fails to work

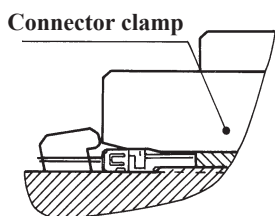

Connector set OK

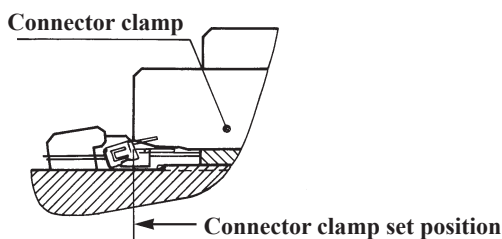

Connector set NG

When the connector clamp is caught on the ground plate and not completely closed even when lightly pressing it by fingers, it is considered that the preliminary insertion of the connector is not properly performed due to the deformation of the ground plate or the like.

Do not perform the work by force. Return again to the state of the preliminary insertion of the ground plate

5. Connection work

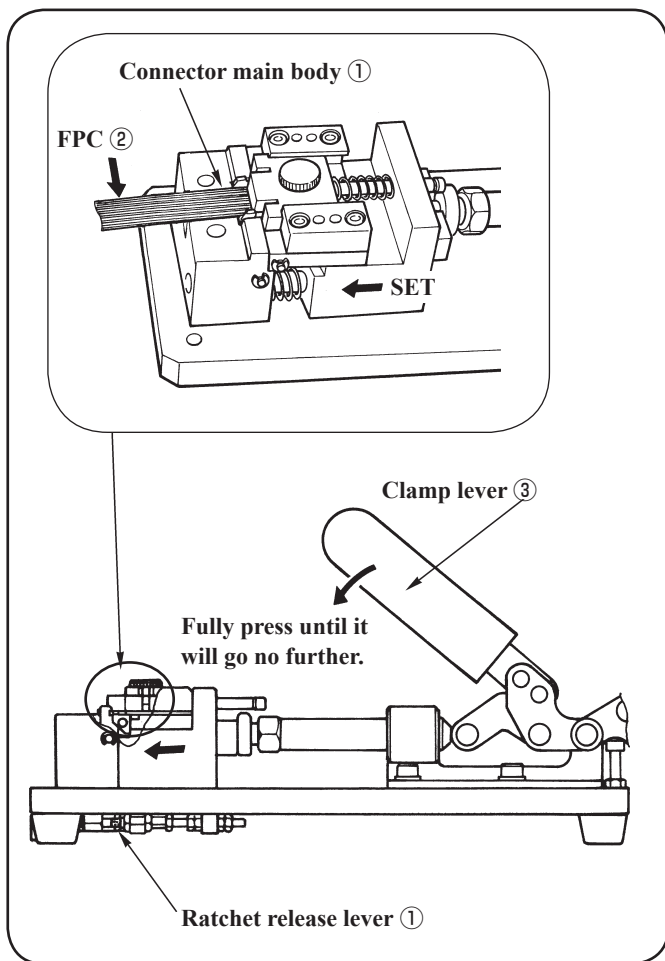

WARNING :

Exercise care not to allow hands, fingers or the like to be caught in any of the moving parts.

- 1) Making connector main body ① come in contact with the end face of the holder, press FPC ② .
- 2) Fully press down clamp lever ③ until you obtain a feeling of clamping.
- 3) Return upward clamp lever ③ and release it.
- 4) Connection work has been completed.



Releasing procedure of the clamp lever

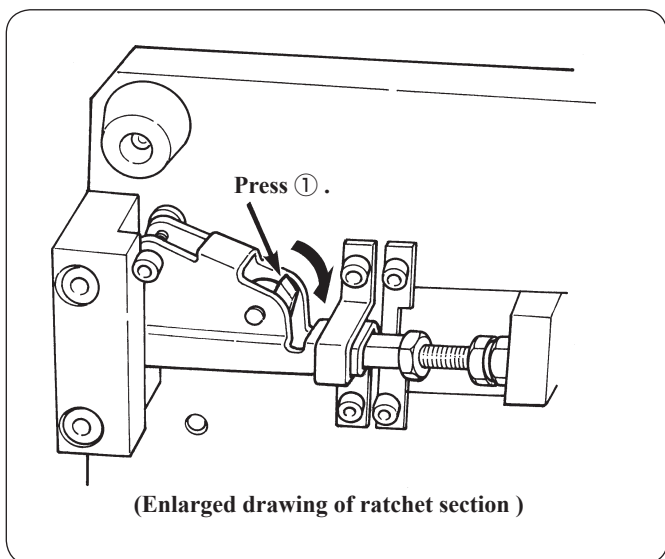

When the ratchet is not released even when the clamp lever has been fully pressed or you want to temporarily stop the clamp lever, do not return the clamp lever by force. Pressing ratchet release lever ① located in the rear of the tool, release the clamp lever.

(See the enlarged drawing of ratchet section.)



Please contact us when the connector cannot be taken out even when the clamp lever has been released or any other trouble has occurred.

6. Appearance inspection

Perform the appearance inspection whether the quality is satisfied when the connection work has been completed.

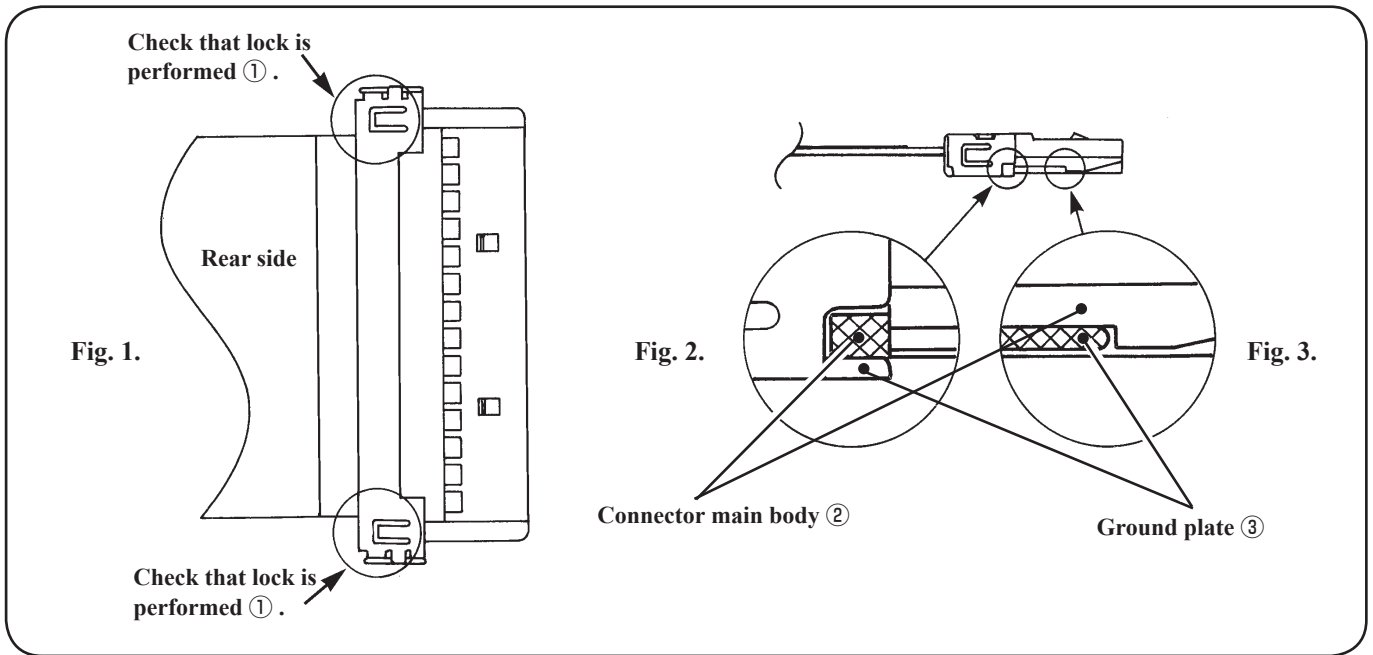

(Inspecting procedure)

Return the clamp lever to its home position and slide the connector clamp by fingers to open it.

Perform the appearance inspection whether the connection is proper after taking out the connector.

- 1) Lock is performed ① . (See Fig. 1.)
- 2) There is no defect in the connector main body ② . (See Fig. 2.)
- 3) There is no rise of ground plate ③ . (See Fig. 3.)
- 4) There is not any other defect such as scratch or the like.

7. Electrical test

Perform the test of Contact resistance, insulation resistance and withstand voltage.

Item	Test method	Standard
Contact resistance	Measure at 100 m A (DC or 1000 Hz)	Less than 50 mΩ
Insulation resistance	Measue at DC 100 V.	More than 500 MΩ
Withstand voltage	Apply AC 300 V voltage for one minute.	No flashover or dielectric breakdown

IV. Repairing procedure in case of failure of connection

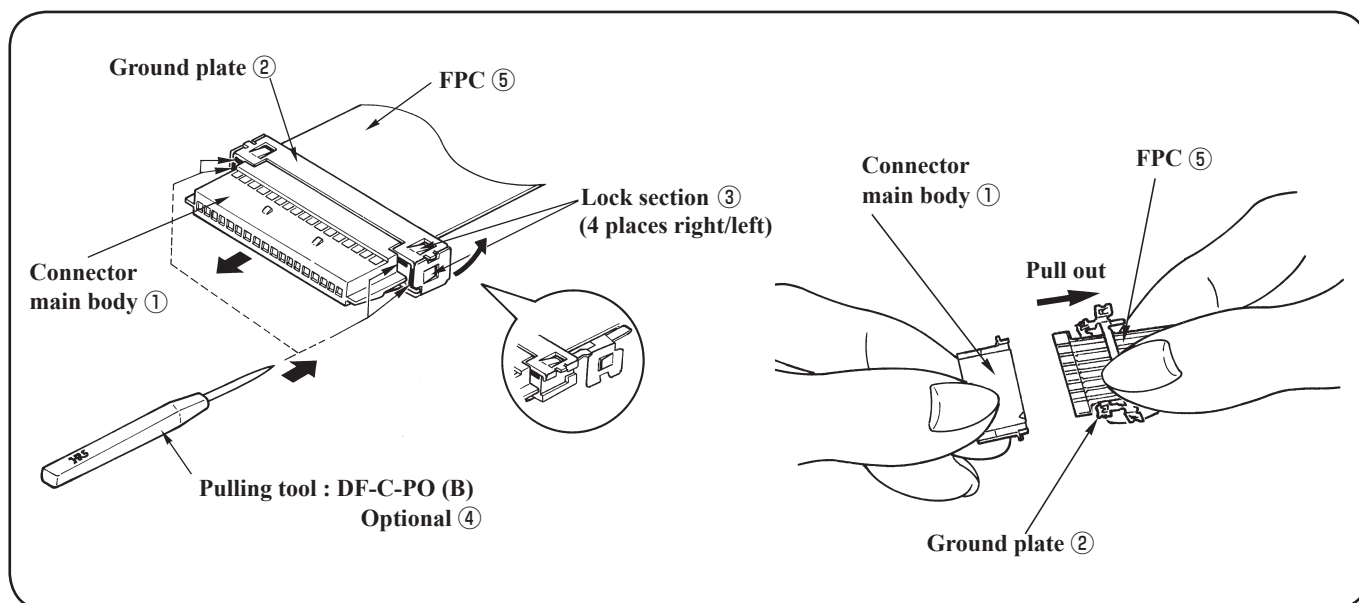

- 1) Turn over the connector main body which has been failed in connection.
- 2) Insert pulling tool (4) between connector main body (1) and lock section (4 places) (3) of ground plate (2) and remove the click.
Pulling tool : DF-C-PO (B) (Optional)
- 3) Press down the ground plate to open it.
- 4) Press FPC (5) and ground plate (2) by fingers and pull out connector main body (1) .
- 5) Remove ground plate (2) from the FPC (5) .



1. Do not perform re-connection of the connector main body and ground plate for which repair has been performed. Scrap them.
2. Do not perform more than one time re-connection to FPC for which repair has been performed.
3. Handle the pulling tool with care since the tip of it is very sharp.

V. Precautions in handling the jig

- 1) Never apply any physical impact to the jig by tapping or dropping from an elevated place.
- 2) Never crimp any material other than applicable connectors and applicable ground plates given in this Instruction Manual.
- 3) When the clamp lever is not released or you want to temporarily stop the clamp lever, never release the lever since releasing it by force will be the cause of trouble.
- 4) If the tool is defective, do not disassemble it but contact us for repair while showing the detailed description of the defect.

VI. Maintenance and inspection

- 1) Upon completion of works, wipe the jig to remove stains and foreign materials with a piece of soft cloth and close the clamp lever to avoid any foreign material from entering the sliding parts. Then, store the jig in a dry place.
- 2) Check to be sure whether there is a feeling of clamping when the clamp lever has been fully pressed and the respective sliding parts smoothly slide.

Instruction Manual Number	
TAD-P6629	
Date of issue	March 2000
Date of revision	December 2013
Edition number	Second edition

CAUTION

- (1) No part of this manual may be reproduced without the permission of Hirose Electric Co., Ltd.
- (2) Description in this manual is subject to change without notice.
- (3) This Instruction Manual has been prepared for clarify. Should you find any unclear portion, error, or omission, please, for the safety of other, contact our Marketing Department.
- (4) It should be understood that, notwithstanding the aforementioned item (3), we assume no liability to any claim for loss or failure to earn profit resulting from the use of the machine.
- (5) We assume no responsibility for any damage resulting from your improper use of the machine including your failure to follow the instructions given in this Instruction Manual. This includes repair or modification conducted by any third party other than Hirose Electric Co., Ltd.
- (6) Please note that servicing of the machine is not available in any country other than Japan.

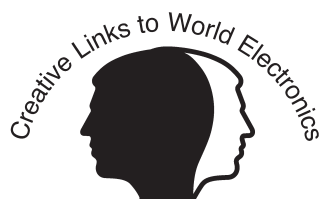

HRS[®]

HIROSE ELECTRIC CO.,LTD.

5-23, OSAKI 5-CHOME, SHINAGAWA-KU, TOKYO 141-8587, JAPAN

PHONE: 81-03-3491-9741 FAX: 81-03-3493-2933

<http://www.hirose.com>

