

DF61Y Series

Compact, Low Profile Wire-to-Board Connector for Power Supply



Power Supply



Compact



Positive-Lock

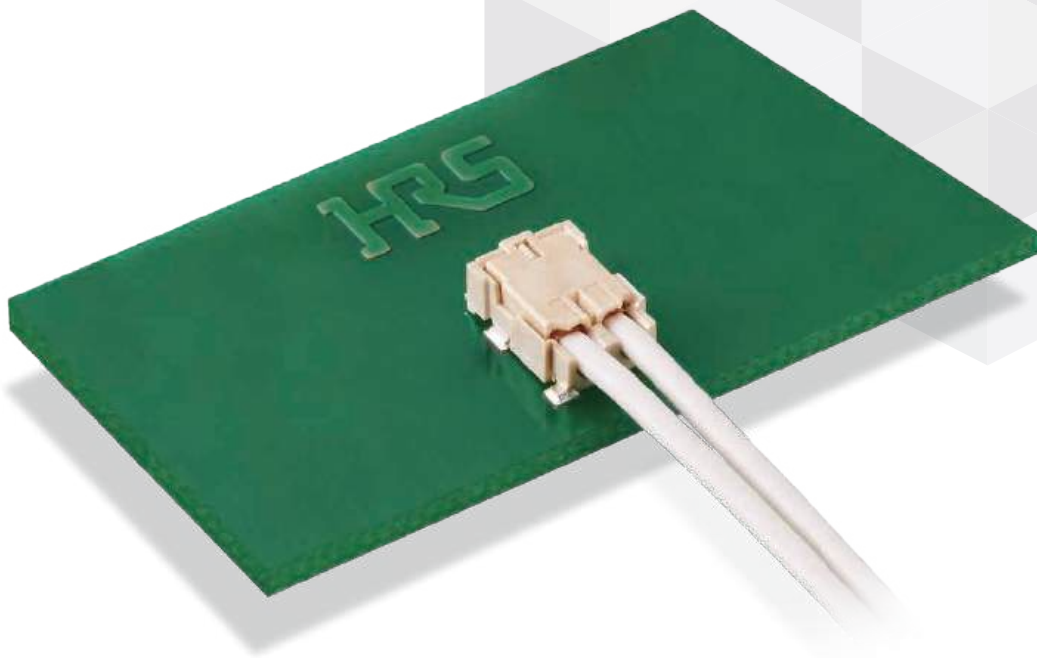

Features

1. Proprietary ViSe Lock design

The lock on the cable side has been strengthened with our proprietary ViSe Lock mechanism (Note 1), preventing cables from being easily disconnected due to tough routing or an excessive load.

Note 1: ViSe lock: Vertical-insertion Swing-extraction
Patent pending

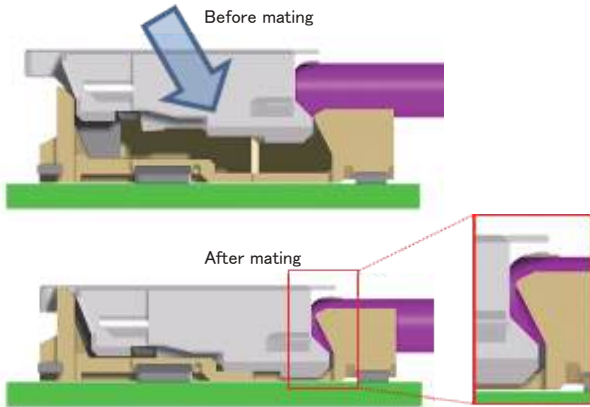

Insertion operation is similar to vertical mating. However, the contact is actually inserted at an angle, and ensures high retention force in upper direction. (Cable tensile strength: A minimum of 10N)

2. Improved operation through vertical mating

Eliminates wasted board space: Vertical insertion eliminates the board space required for horizontal mating and enhances assembly (Enhanced PCB design freedom)

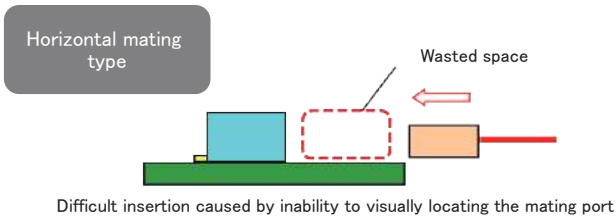
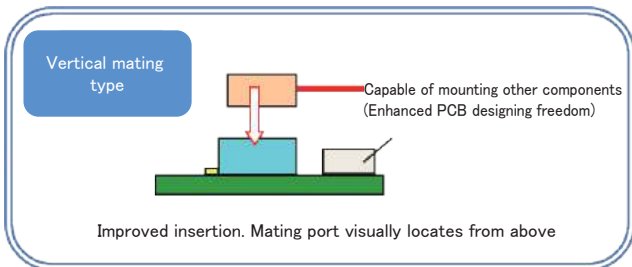

Mar.1.2026 Copyright 2026 HIROSE ELECTRIC CO., LTD. All Rights Reserved.

3. Compact and low profile, with high voltage and current (H=2mm, 24AWG: 4A Max.)

In spite of the small size on a 2.2mm contact pitch, high voltage of 350V is achieved by ensuring creepage distance. Using high conductivity material for the socket contact and lowering contact resistance through optimized contact force, high-current capability is realized.

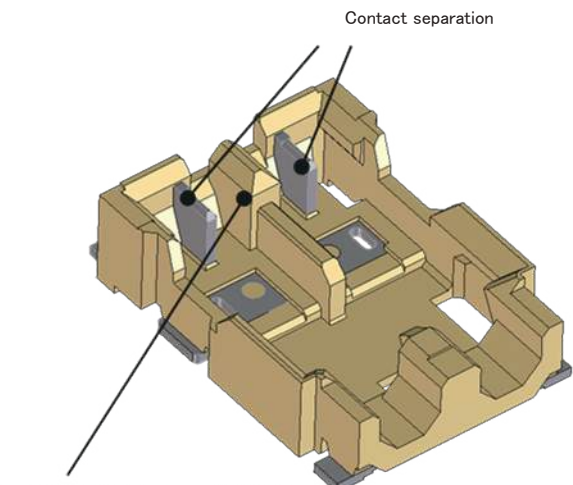

Creepage distance is achieved by providing a housing wall between contacts.

4. High heat-resistance

Operating temperature limit of 105°C.

5. Halogen-free

Use of chlorine or bromine are within standards values.

* As defined by IEC61249-2-21, Br 900ppm Max, Cl 900ppm Max., Br+Cl 1,500ppm max

Product Specifications

Rated Current	No of Pos.	28 AWG	26 AWG	24 AWG	Operating Temperature	-40 to +105°C (Note1)
	2	3.0A	3.2A	4.0A	Storage Temperature	-10 to +60°C (Note2)
	3	2.8A	3.2A	4.0A	Operating Humidity Range	20 to 80%
Rated Voltage	350V AC/DC			Storage Humidity Range	40 to 70% (Note2)	

Item	Specifications	Conditions
Insulation Resistance	1,000M Ω Min.	500V DC
Withstanding Voltage	No flashover or breakdown	1,200V AC for 1 min.
Contact Resistance	10m Ω Max.	20mV Max., 1mA (DC or1,000Hz)
Vibration	No electrical discontinuity of 1 μ s or more	Frequency: 10 to 55Hz, single amplitude of 0.75mm, 10 cycles in each of the 3 directions
Shock	No electrical discontinuity of 1 μ s or more	Acceleration of 490m/s ² , 11ms, sine half-wave waveform, 3 cycles in each of the 3 axes
Humidity	Contact Resistance: 20m Ω Max. Insulation Resistance: 500M Ω Min.	Temperature: 40 ± 2°C , humidity: 90 to 95%, left as it is for 96 hours
Temperature Cycle	Contact Resistance: 20m Ω Max. Insulation Resistance: 500M Ω Min.	(-55°C : 30min. → +5 to +35°C : 2 to 3min. → +105°C : 30min. → +5 to +35°C : 2 to 3min.) 5 cycles
Mating Durability	Contact Resistance: 20m Ω Max.	30 times
Resistance to Soldering Heat	The resin components will not become deformed or lose performance due to deformities	Reflow: according to the recommended temperature profile Manual soldering: temperature of soldering iron at 350 ± 10°C , 3sec

Note 1: Includes the temperature rise caused by current flow.

Note 2: The storage condition refers to long-term storage of the product on the shelf before assembly. Please use the operating temperature for temporary storage such as pre-assembly and during shipping.

Materials / Finish

Product	Part	Material	Color/Finish	Remarks	RoHS2
Header	Insulator	LCP	2pos.: Natural	UL94V-0	Yes
			3pos.: Black		
	Contact	Brass	Tin Plated	-	
Crimp Socket	Insulator	LCP	2pos.: Natural	UL94V-0	
			3pos.: Black		
Crimp Contact	Contact	Copper Alloy	Tin Plated	-	

Product Number Structure

Refer to the chart below when determining the product specifications from the product number.
Please select from the product numbers listed in this catalog when placing orders.

Header Connector

DF 61Y - # P - 2.2 V

① ② ③ ④ ⑤ ⑥

① Series Name	DF	⑤ Pitch	2.2mm
② Series No.	61Y	⑥ Termination Type	V : SMT Vertical Type
③ No. of Pos.	2, 3		
④ Connector Type	P: Header		

Socket Connector

DF 61Y - # S - 2.2 C

① ② ③ ④ ⑤ ⑥

① Series Name	DF	⑤ Pitch	2.2mm
② Series No.	61Y	⑥ Termination Type	C: Crimp Socket
③ No. of Pos.	2, 3		
④ Connector Type	S: Socket		

Contact

DF 65 - 2428 SCF

① ②

① Applicable Wire Size	2428: 24-28 AWG	② Packaging Style	SCF: Socket Crimp Contact · Reel
------------------------	-----------------	-------------------	----------------------------------

Straight Header (SMT)



DF61Y-2P-2.2V(23)

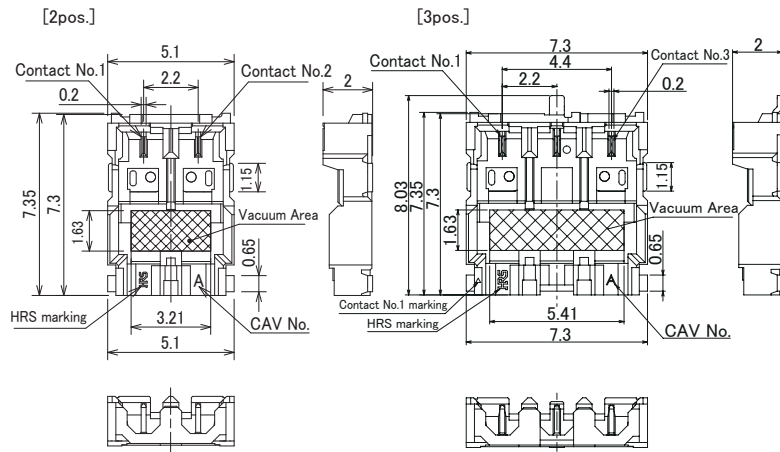

Part No.	HRS No.	No. of Pos.	Color	Specification Number	Purchase Unit
DF61Y-2P-2.2V(23)	CL0666-5100-3-23	2	Natural	(23): Tin plated, embossed packaging	3,000pcs per reel
DF61Y-3P-2.2V	CL0666-5103-0-00	3	Black	None: Tin plated, embossed packaging	2,400pcs per reel

② If the area contains a pattern and used at the rated voltage of 350V, the creepage distance could be insufficient.

Recommended PCB layout (t=1 mm)

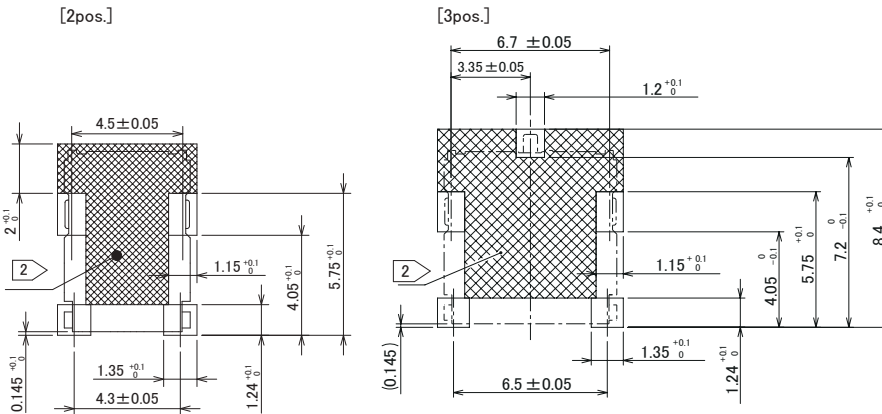

Tape and Reel Dimensions

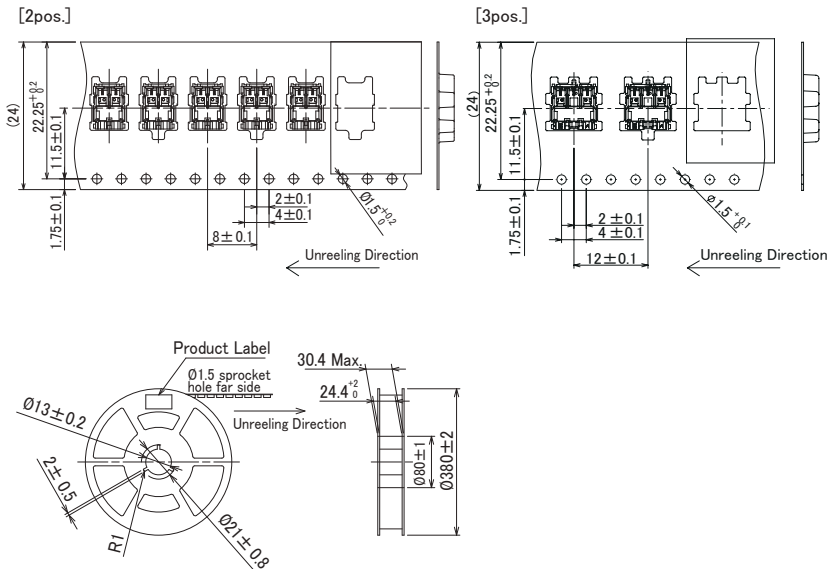

Socket



DF61Y-2S-2.2C(13)

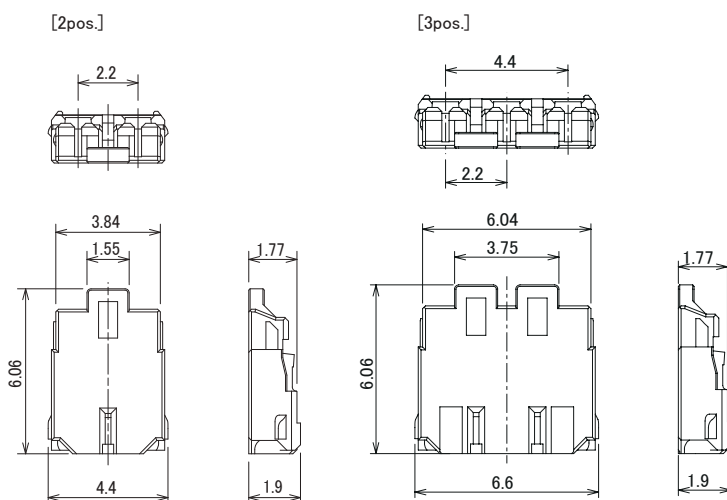

Part No.	HRS No.	No. of Pos.	Color	Purchase Unit
DF61Y-2S-2.2C(13)	CL0666-5101-6-13	2	Natural	1,000pcs per bag
DF61Y-3S-2.2C	CL0666-5102-0-00	3	Black	1,000pcs per bag

Crimp Contact

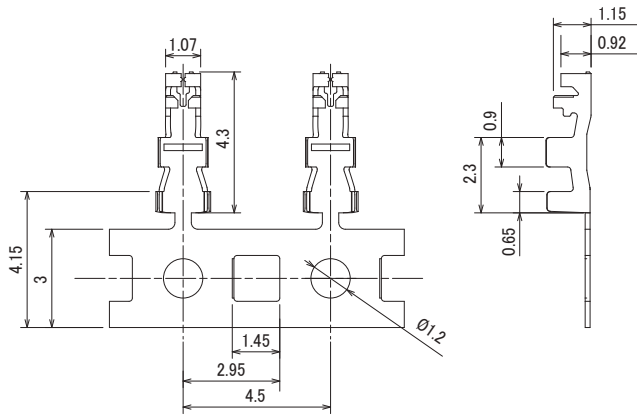

Part No.	HRS No.	Packaging	Finish	Purchase Unit
DF65-2428SCF	CL0666-6003-2-00	Reel	Tin Plating	1,800pcs per reel

● Applicable Wire (Tin plated annealed copper wire)

Wire size (Stranded wire conductor)	Jacket Outer Diameter	Recommended Cable	Strip Length
24AWG (11/ ϕ 0.16mm)	ϕ 1.11mm	UL10368	1.4 to 1.8mm
26AWG (7/ ϕ 0.16mm)	ϕ 0.98mm		
28AWG (7/ ϕ 0.127mm)	ϕ 0.88mm		

Note 1: For applicable cable other than those listed above, refer to Crimp Condition Table. Crimp Condition Table is available on product web page.

(If you are using a cable that is not listed in Crimp Condition Table, please contact a Hirose sales representative.)

Note 2: The strip length is a reference value. Please make adjustments so finished crimps will meet the specified values. Refer to the crimping quality standards for details.

Applicable Crimping Tools

Type	Part No.	HRS No.	Applicable Contact
Applicator	AP105-DF65-2428S	CL0901-4630-0-00	DF65-2428SCF
Press Body	CM-105	CL0901-0005-4-00	
Hand Tool	HT305/DF65-2428S	CL0550-0306-8-00	
Extraction Tool	DF-C-PO(B)	CL0550-0179-2-00	

Note: If any trouble has occurred due to tools other than the designated tool, Hirose bears no responsibility for any trouble.

Operating Precautions

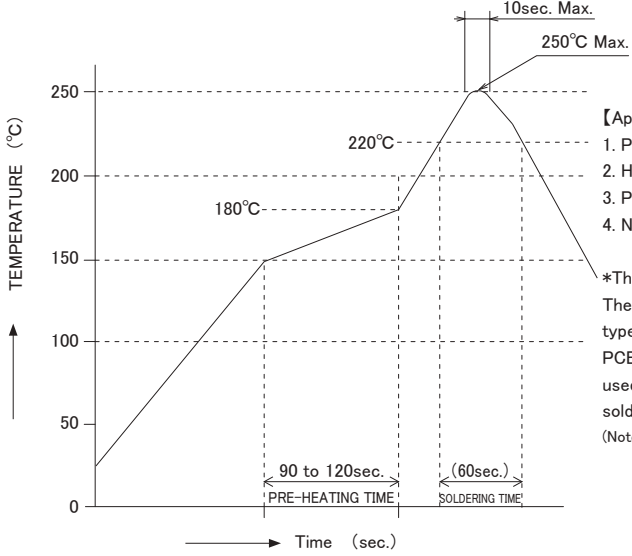
<p>Recommended Temperature Profile (Lead-free soldering available)</p>	 <p>TEMPERATURE (°C)</p> <p>Time (sec.)</p> <p>90 to 120sec. PRE-HEATING TIME</p> <p>180°C</p> <p>220°C</p> <p>250°C Max.</p> <p>10sec. Max.</p> <p>60sec. SOLDERING TIME</p> <p>【Applicable Conditions】</p> <ol style="list-style-type: none"> 1. Peak Temperature: 250°C Max. 2. Heated Area: 220°C Min., within 60sec. 3. Pre-heating Area: 150 to 180°C, 90 to 120sec. 4. Number of Operation: Twice Max. <p>*The contact lead area was measured. The conditions may change depending on the types and manufacturers of cream solder, PCB size, and conditions of other materials used for soldering. Please fully check the soldering condition before use. (Note 1) This temperature profile is our recommended value.</p>
<p>Recommended Hand Solder Conditions</p>	<p>Soldering iron temperature: $350 \pm 10^{\circ}\text{C}$, soldering time: within 3sec.</p>
<p>Recommended Screen Thickness, Aperture Opening Rate (Pattern Area Ratio)</p>	<p>Thickness: 0.1mm aperture opening rate: 100%</p>
<p>PCB Warpage</p>	<p>0.02mm Max. at the center of connector with the both edges of the connector as the baseline</p>
<p>Cleaning Condition</p>	<p>Cleaning with IPA is possible. (Cleaning is not recommended as it may change the feel of insertion/extraction, etc. Please consult with us when using other types of cleaning agents.)</p>
<p>Precautions</p>	<ul style="list-style-type: none"> ■ Insertion/extraction of the connector while not mounted to the PCB may cause breakage or deformation to the contact. ■ Do not apply flux at the time of hand soldering, as it may result in flux rise. ■ This product may have slightly different hue on molded items, however, they do not affect the product performance. Black spots may appear on the mold resin but this does not affect the product quality. ■ See the "DF61Y Product Guidelines (Mating/Unmating Operation Instruction Manual)" on our website for handling precautions at the time of insertion and extraction.

Insertion and removal operation

Insertion operation

Insertion operation shall be carried out in steps (1) placing the crimp socket, (2) insertion, and (3) check the mated state.

(1) Placing the crimp socket

Place the crimp socket so that the friction locks in 4 places in front and behind the crimp socket come into contact with the header.

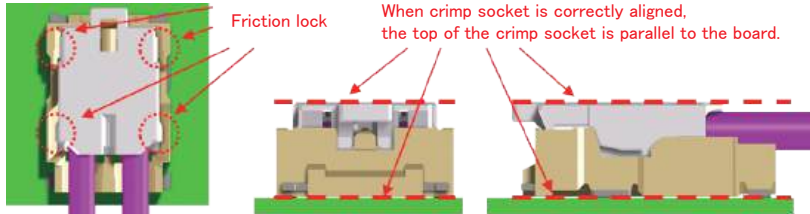

(2) Insertion

Press down on the center of the crimp socket, and mating is complete.

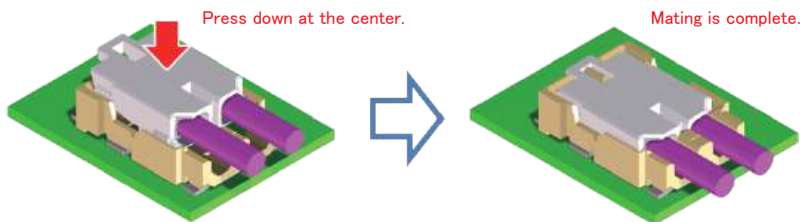

(3) Checking the mated state

Check if the crimp socket is securely mated. If one end floats or is mated at an angle, unmate, and mate it again.



When the crimp socket is inserted, it is possible that only the friction lock on the cable side is inserted, as shown in the Figure below.

In this case, push the non-cable side of the crimp socket to correctly mate.

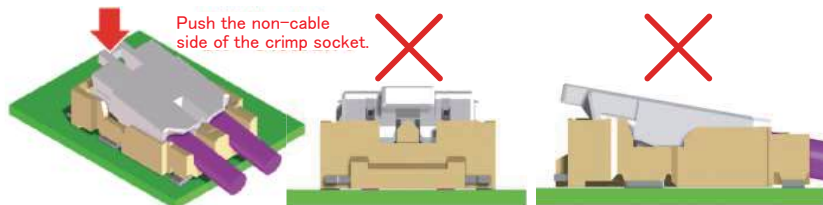

If the connector is inserted when the crimp socket isn't placed correctly, it is possible that only the friction lock on the non-cable side is inserted, as shown in the Figure below.

In this case, unmate, and mate again. Forcible mating will lower the retention force.

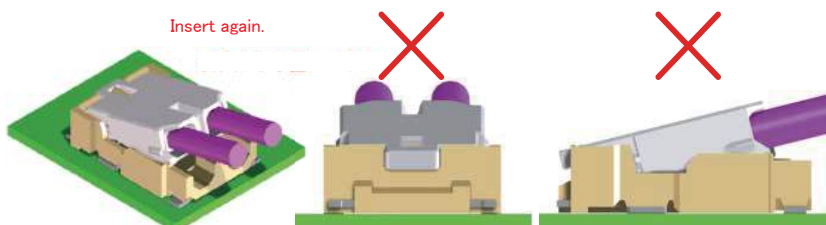

Removal Operation

To remove the cable, first place your fingernail or finger on the release tab for unlocking crimp socket, lift the tab, and release the friction lock on the non-cable side.

Then, lift the entire crimp socket to complete the removal operation.

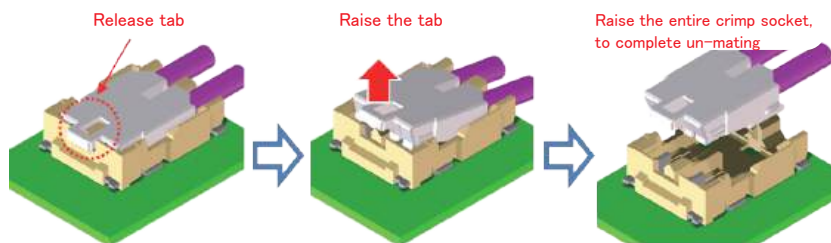

Use the tab to help release .

If the connector is forcibly removed by pulling the cable, cable disconnection and connector breakage will occur.



While Taking into Consideration

Specifications mentioned in this catalog are reference values.

When considering to order or use this product, please review the Drawing and Product Specifications sheets.

Use an appropriate cable when using the connector in combination with cables.

If considering usage of a non-specified cable, please contact your sales representative.

If assembly process is done by jigs & tools which are not identified by Hirose, the warranty of the product may be affected.

If considering usage for below mentioned applications, please contact your sales representative.

In cases where the application will demand a high level of reliability, such as automotive, medical instruments, public infrastructure, aerospace/defense etc. Hirose must review before assurance of reliability can be given.

HIROSE

HRS

HIROSE ELECTRIC CO.,LTD.

2-6-3 Nakagawa Chuoh, Tsuzuki-Ku, Yokohama-Shi 224-8540, JAPAN
<https://www.hirose.com>