

Oct.1.2024 Copyright 2024 HIROSE ELECTRIC CO., LTD. All Rights Reserved.
In case of consideration for using Automotive equipment / device which demand high reliability, kindly contact our sales window correspondents.

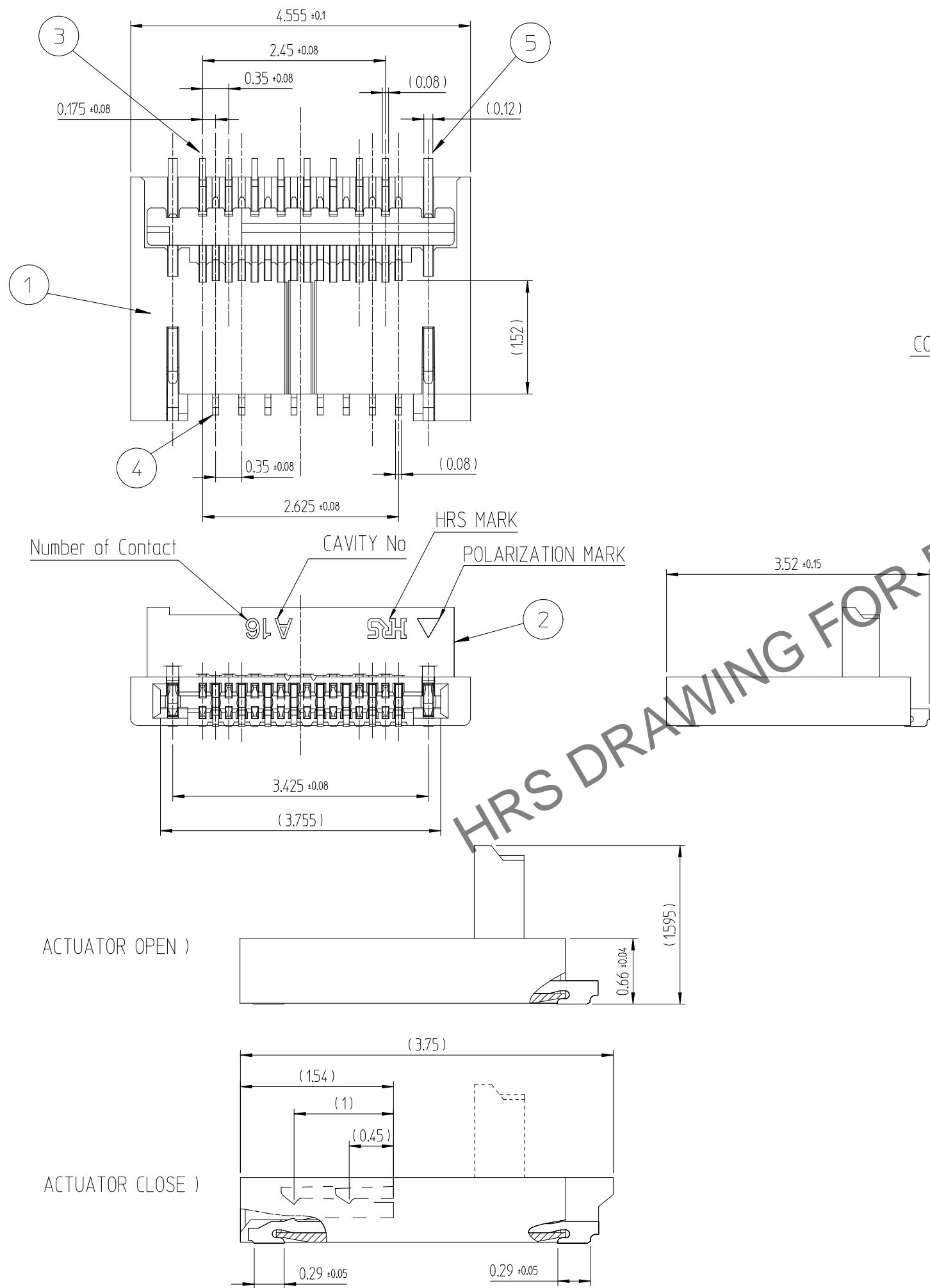

| △數 COUNT | 訂正事項 DESCRIPTION OF REVISIONS | 擔當 B | 檢圖 Y | 年月日 DATE | △數 COUNT | 訂正事項 DESCRIPTION OF REVISIONS | 擔當 B | 檢圖 Y | 年月日 DATE |
|-------------|----------------------------------|---------|---------|-------------|-------------|----------------------------------|---------|---------|-------------|
| △ | RE-5-1833 | OCU | CDH | 17. 12. 04 | △ | | | | .. |
| △ | | | | .. | △ | | | | .. |
| △ | | | | .. | △ | | | | .. |

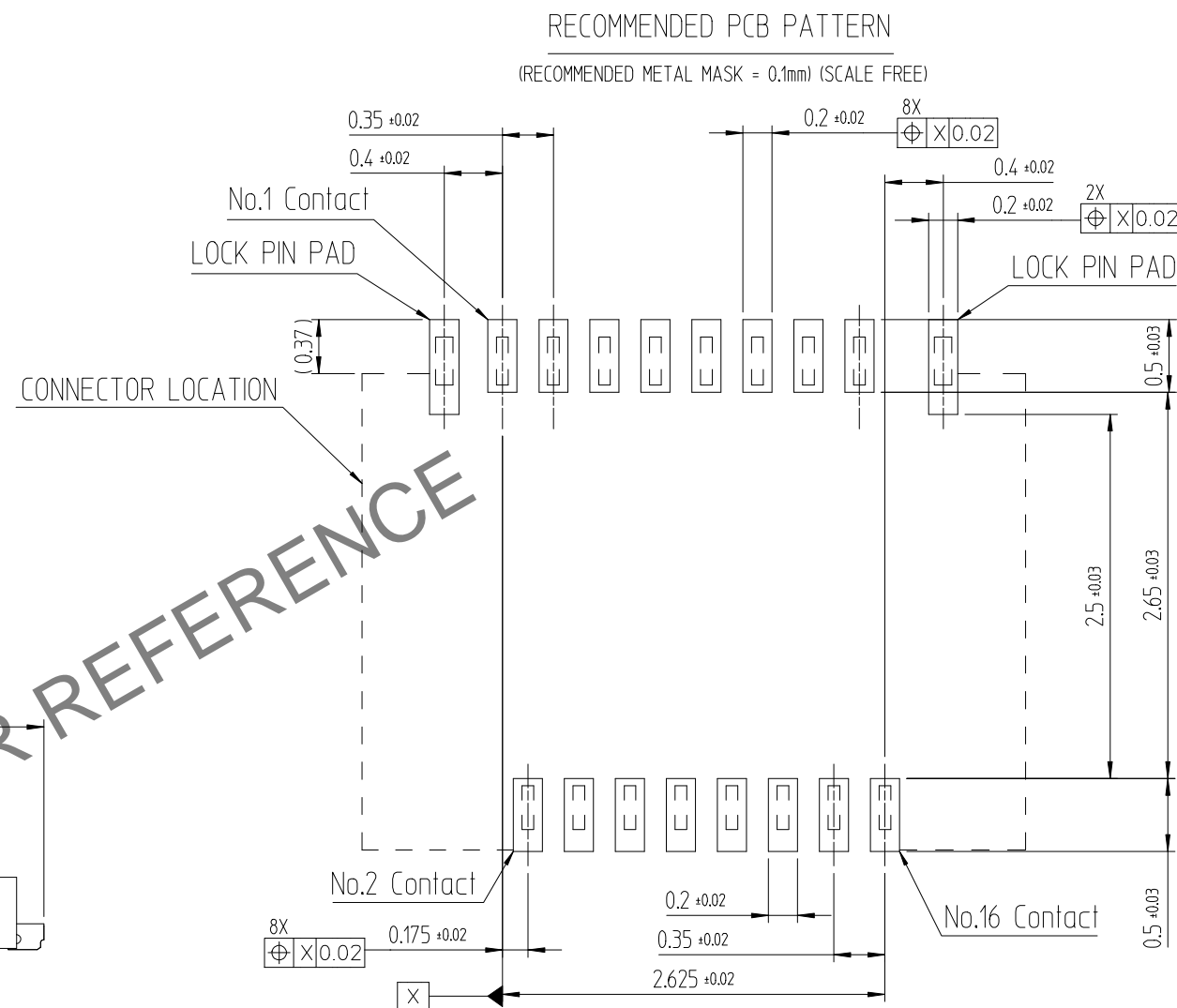

HRS DRAWING FOR REFERENCE

NOTE
 1. EMBOSS PACKING
 2. LEAD CO-PLANARITY SHALL BE 0.08mm MAX
 3. LOCK PIN CAN NOT BE USED FOR SIGNAL CONNECTION
 ALSO, IF GROUND WAS MOUNTED ON THE LOCK PIN PAD,
 IT WOULD BE OCCURED ELECTRICAL SHORT.
 PLEASE DO NOT MOUNTED GROUND ON THE LOCK PIN PAD.

| | | | | | | |
|----------------------------|-----------------|--|----------------------------------|---------------------|--|-------------------------|
| 3 | PHOSPHOR BRONZE | (CONTACT AREA) Au 0.054μm MIN OVER Ni 14μm (LEAD AREA) Au 0.054μm MIN OVER Ni 14μm (OTHER) Ni PLATING 14μm MIN | 5 | PHOSPHOR BRONZE | Ni 14μm + SN 14μm MIN | |
| 2 | PA9T(GP2450NH) | BLACK UL94-0 | 4 | PHOSPHOR BRONZE | (CONTACT AREA) Au 0.054μm MIN OVER Ni 14μm (LEAD AREA) Au 0.054μm MIN OVER Ni 14μm (OTHER) Ni PLATING 14μm MIN | |
| 1 | LCPS475) | BLACK UL94-0 | | | | |
| CODE NO. (OLD) | | DRAWN | DESIGNED | CHECKED | APPROVED | RELEASED |
| | | C.U,Oh 13.12.02 | C.U,Oh 13.12.02 | D.H,Cho 13.12.02 | H.C.SONG 13.12.02 | ENG 18.02.19 DEPT |
| DRAWING NO. EDC3-631612-80 | | | PART NO. TF22-16S-0.175SHW (800) | | | |
| SCALE 15:1 | | | CODE NO. CL 6540-0001-3-800 | | | |
| UNITS mm | | | HRS HIROSE KOREA CO.,LTD. | | | |
| | | | 1/7 | | | |

Oct.1.2024 Copyright 2024 HIROSE ELECTRIC CO., LTD. All Rights Reserved.
 In case of consideration for using Automotive equipment / device which demand high reliability, kindly contact our sales window correspondents.

RECOMMENDED FPC (FREE)

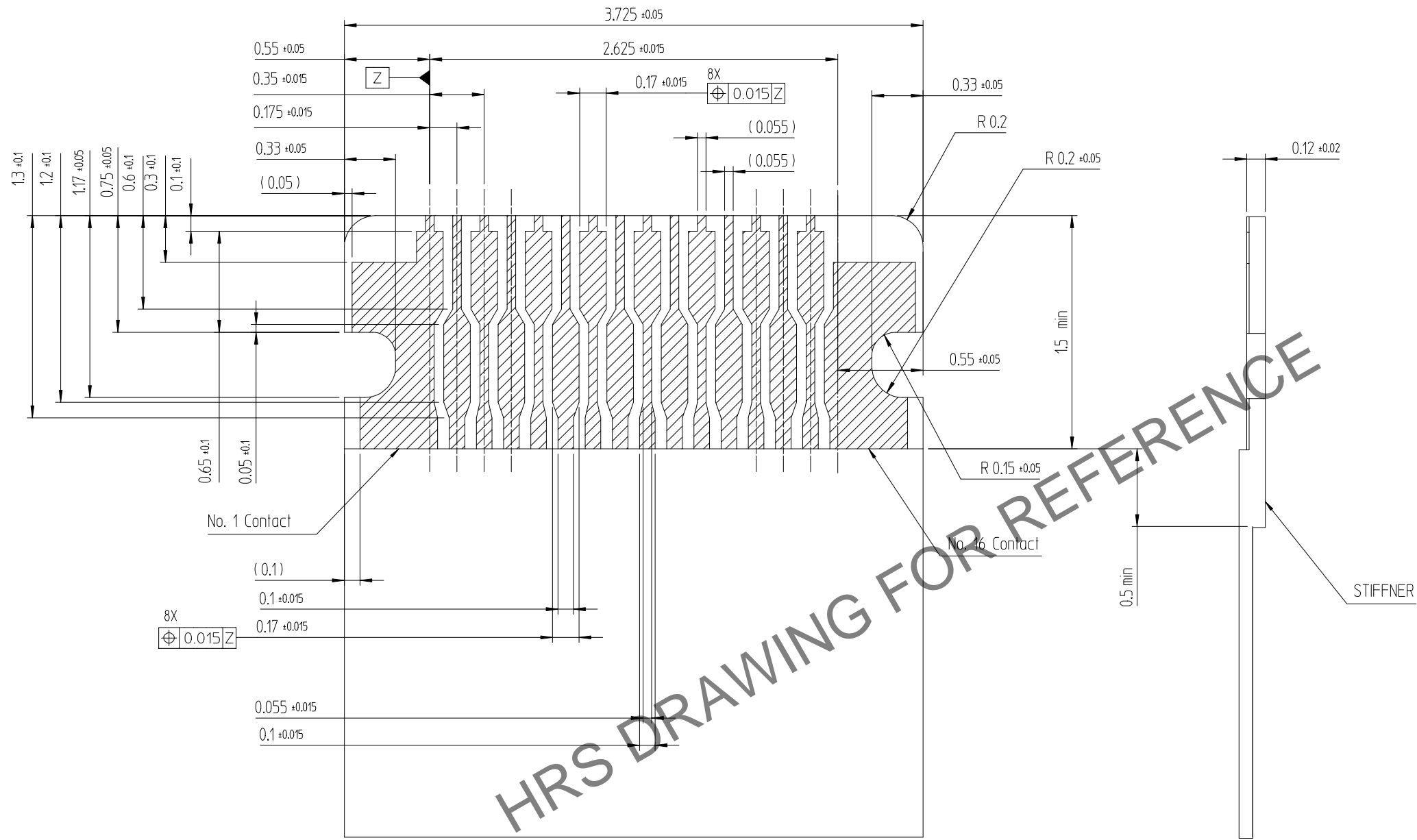

FPC CONSTRUCTION (Recommended Specifications)

| | MATERIAL NAME | MATERIAL | THICKNESS(μm) |
|--|---------------------------------|------------------------|---------------|
| | COVERING FILM LAYER. | POLYAMIDE 1mil thick | 25 |
| | COVER ADHESIVE | | 25 |
| | SURFACE TREATMENT | PLATING TREATMENT | (4) |
| | COPPER FOIL | C u 1/3 oz | 12 |
| | BASE ADHESIVE | | |
| | BASE FILM | POLYAMIDE 1mil thick | 25 |
| | REINFORCEMENT MATERIAL ADHESIVE | HEAT-HARDENED ADHESIVE | 30 |
| | STIFFENER | POLYAMIDE 2mil thick | 50 |

Oct.1.2024 Copyright 2024 HIROSE ELECTRIC CO., LTD. All Rights Reserved.
In case of consideration for using Automotive equipment / device which demand high reliability, kindly contact our sales window correspondents.

DIRECTION OF PULLING OUT

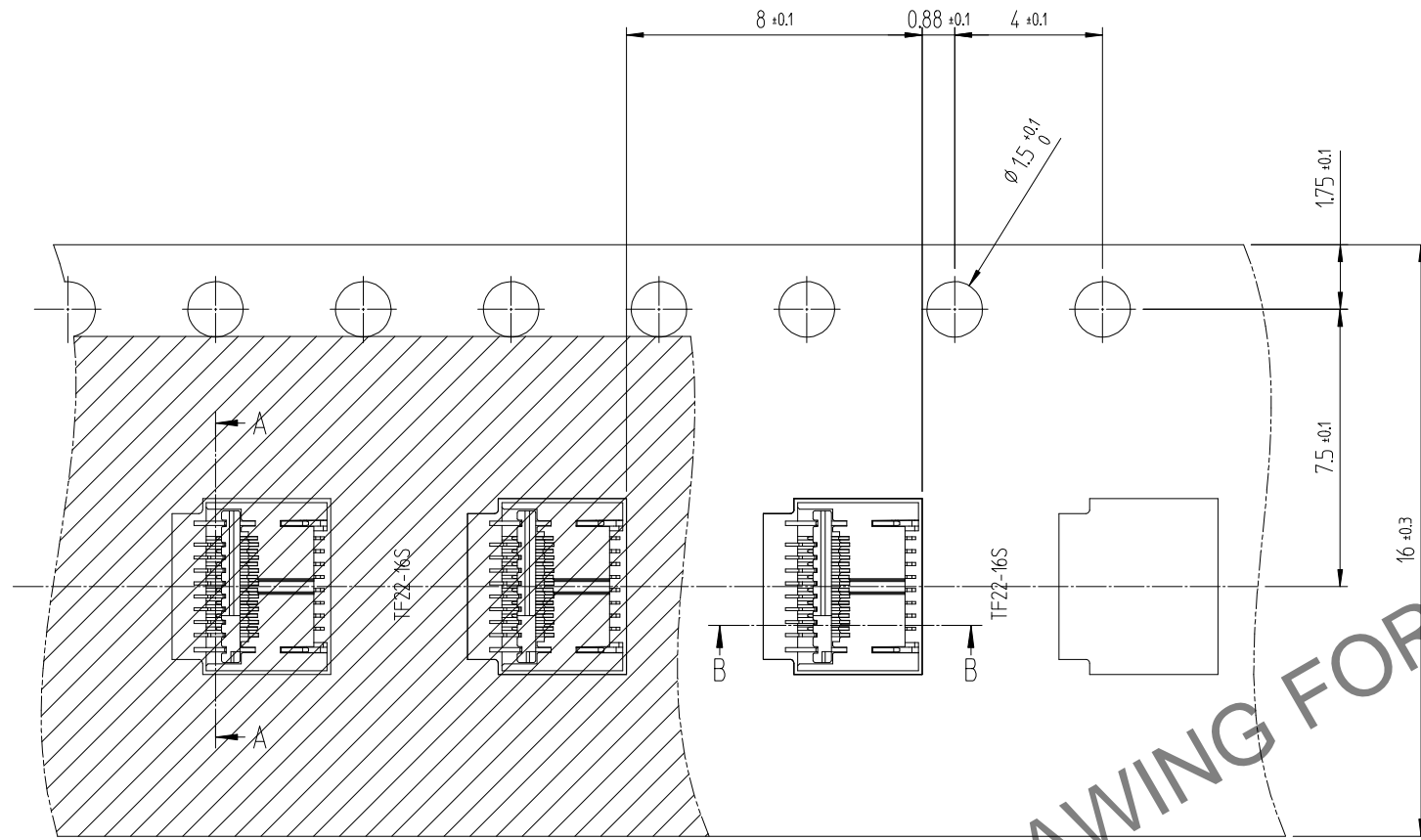

Section A-A

STYLE AND DIMENSION OF REEL(FREE)

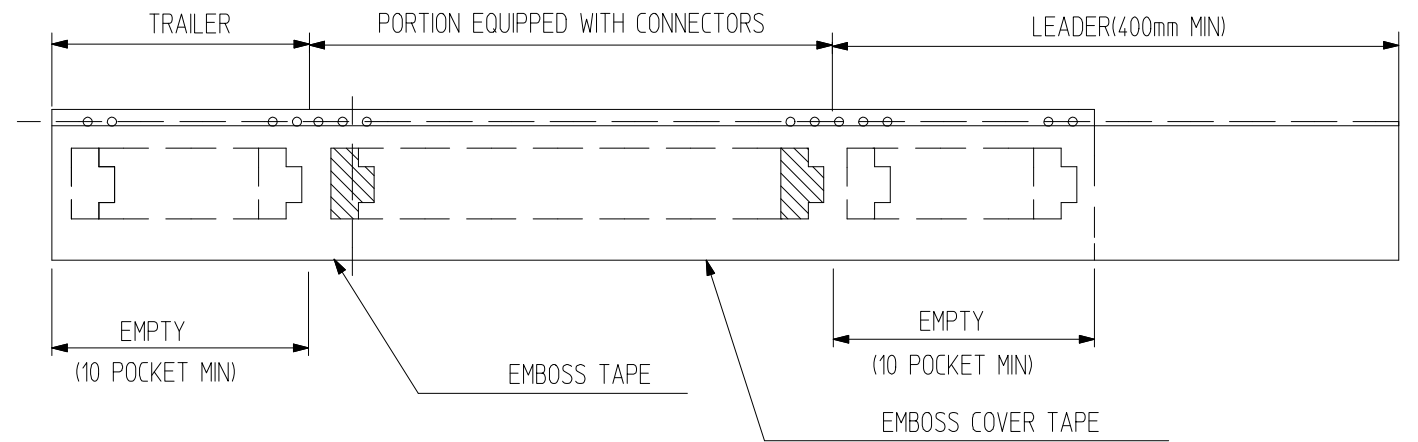
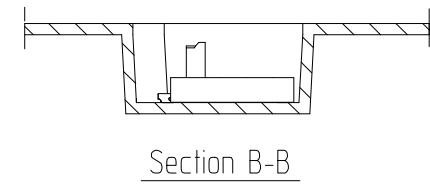
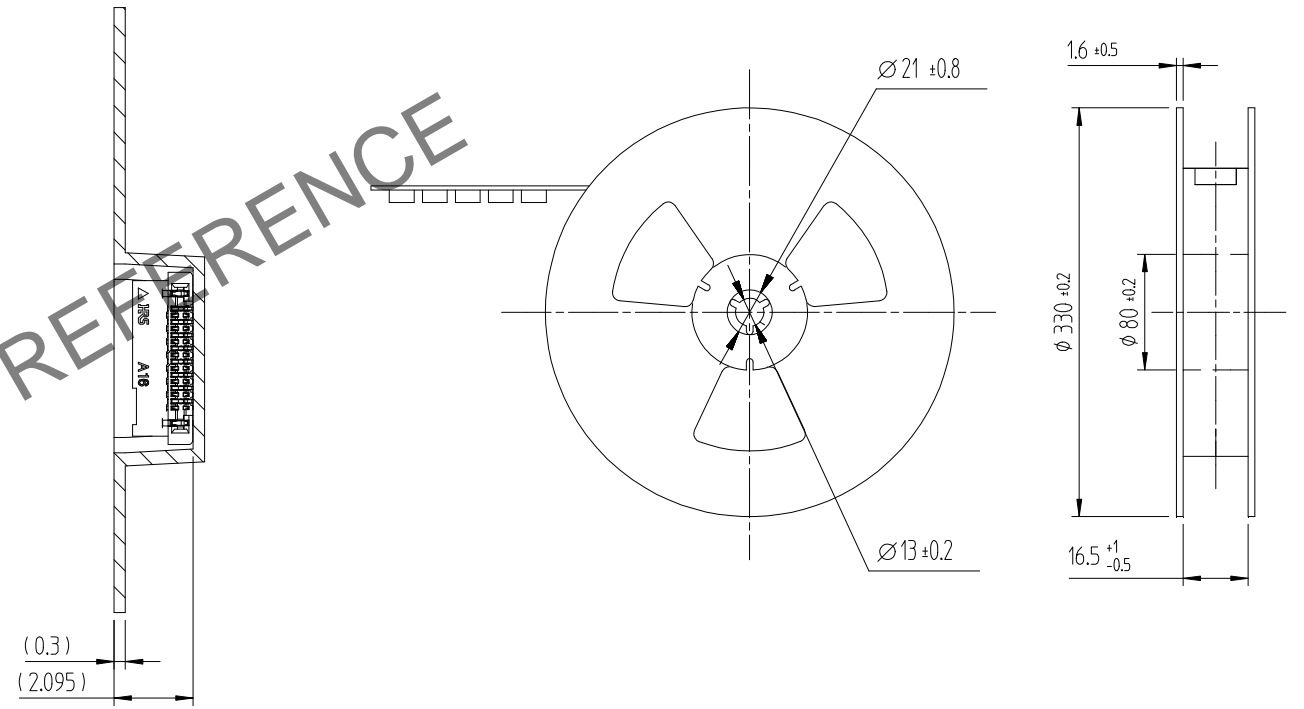

NOTE1. 1REEL: 5,000EA CONNECTORS

Oct.1.2024 Copyright 2024 HIROSE ELECTRIC CO., LTD. All Rights Reserved.
In case of consideration for using Automotive equipment / device which demand high reliability, kindly contact our sales window correspondents.

This connector features small, thin and back flip design, requiring delicate and careful handling.
To prevent connector/FPC breakage and contact failure (mating failure, FPC pattern breakage, etc).
read through the instructions shown below and handle the connector properly.
Each values indicating here are for reference and may differ from standard value.

[Operation and Precautions]

1. Initial condition

Actuator does not have to be operated before inserting FPC,
as the connector is delivered with the actuator opened.

[Caution]

- Do not close the actuator before inserting FPC.
Closing the actuator without FPC could make the contact gap smaller, which could increase the FPC insertion force.
- Do not insert FPC or operate actuator before mounting.

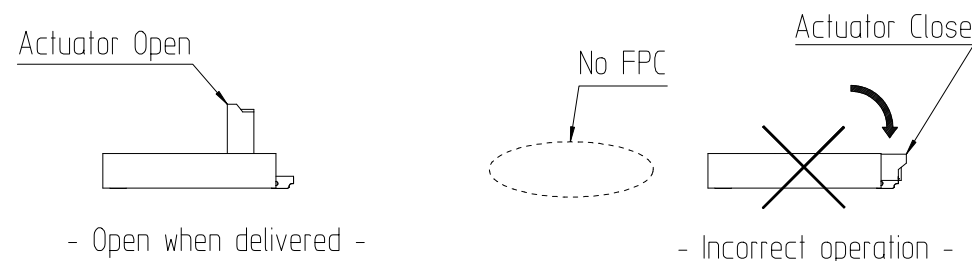

2. How to insert FPC

This connector has contacts on the top. Insert the FPC with the exposed conductors face up.

[Caution]

- Insert the FPC with the actuator opened.
- Do not insert the FPC with the conductor surface face down.
- Insert the FPC into the connector opening horizontally to the PCB plane.
Insert it properly to the very end.
- Do not twist the FPC to up and down, right and left or an angle.

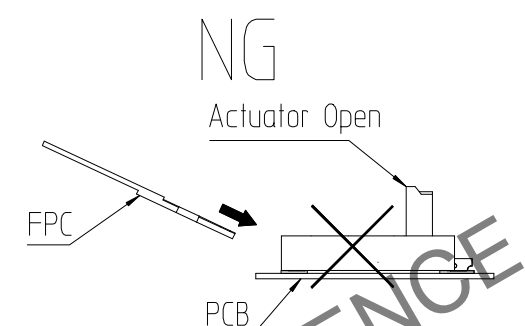
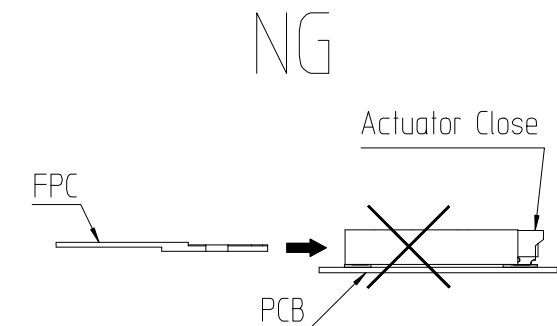
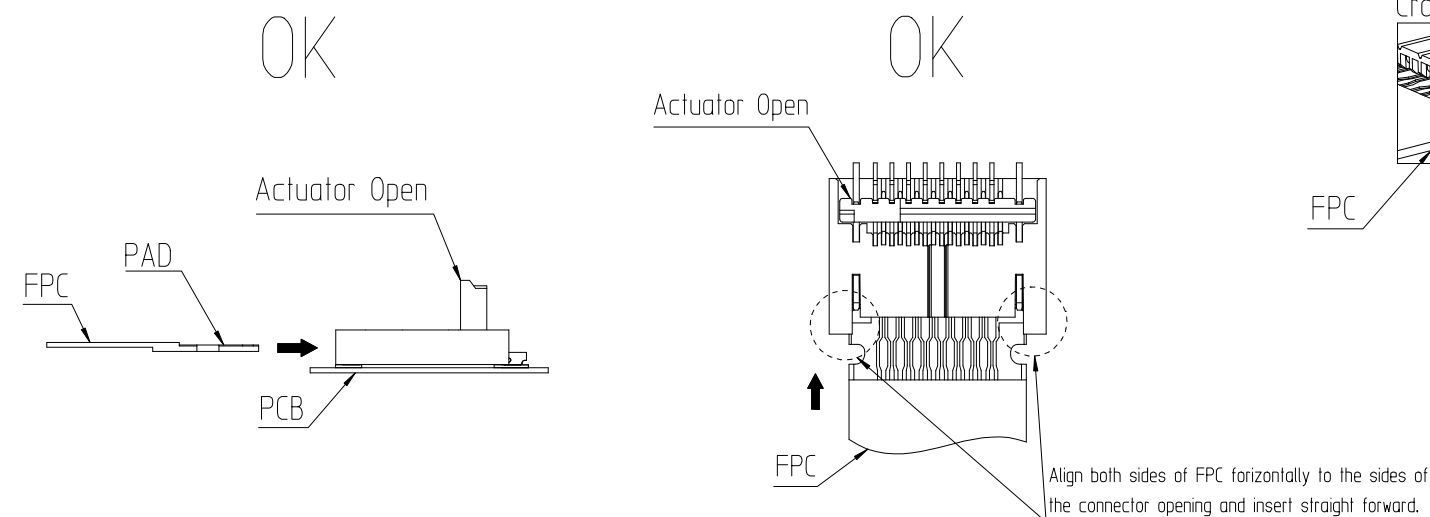

3. FPC insertion check

Make sure that the FPC tabs are located in proper position as shown in the figure below after FPC insertion.

[Caution]

Do not insert the FPC at an angle and/or stop it before insertion is completed.

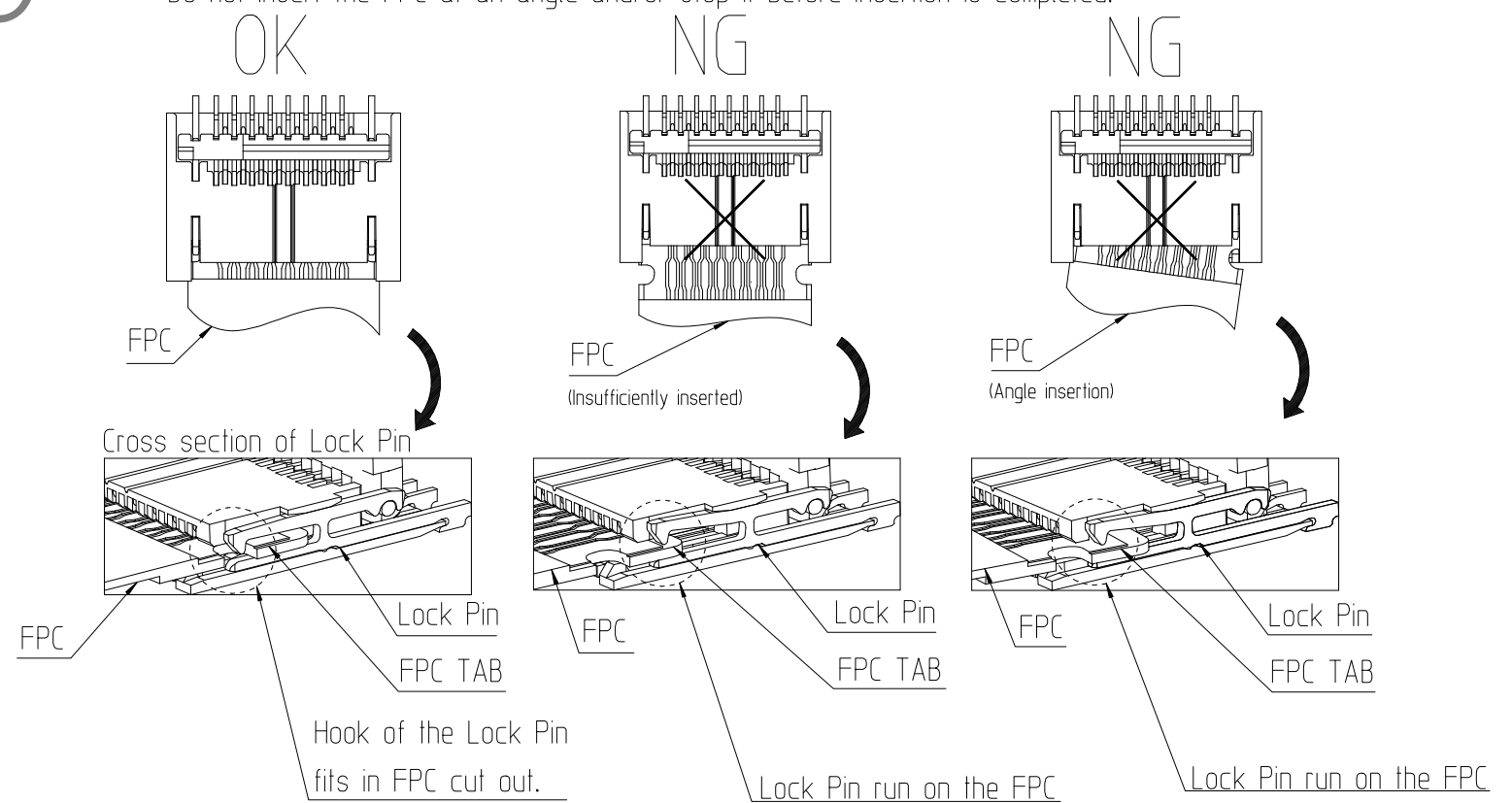

< INSTRUCTION MANUAL (1) >

Oct.1.2024 Copyright 2024 HIROSE ELECTRIC CO., LTD. All Rights Reserved.
In case of consideration for using Automotive equipment / device which demand high reliability, kindly contact our sales window correspondents.

4. How to lock

Apply load to rotate the actuator by 90 degree after inserting the FPC.

[Caution]

- The actuator rotates around the rotational axis as shown below.
- Do not rotate the actuator to the counter direction.
- Do not pinch or pick the actuator to lift.
- Operate the actuator by hand without using sharp tool such as Tweezers.
- To close the actuator, operate at the center of the actuator.
- To close the actuator, do not operate the actuator at one end only.
- Do not apply excess force to the housing during the operation.

[Actuator movable range]
(Side view)

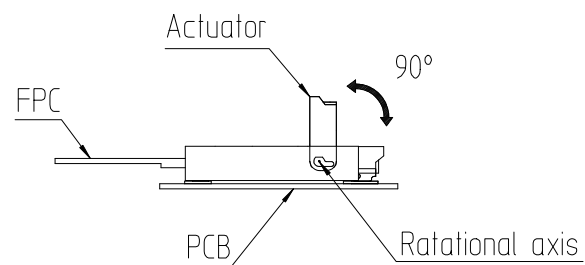

OK

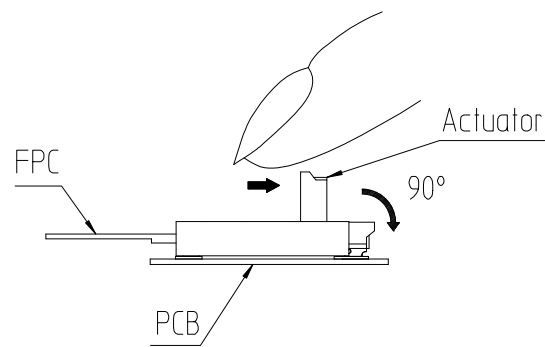

NG

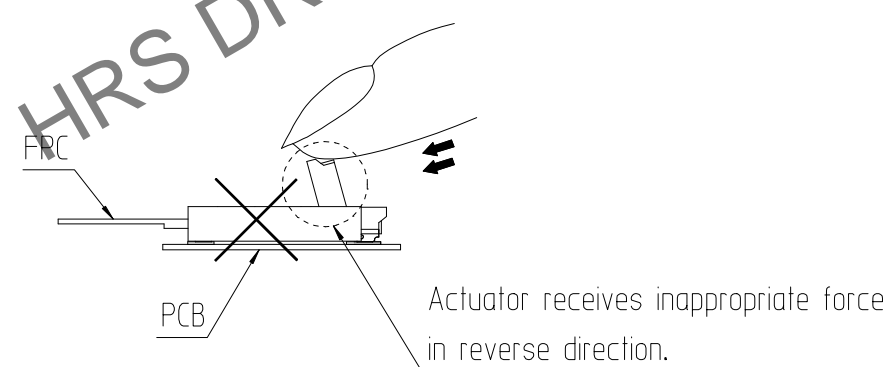

NG

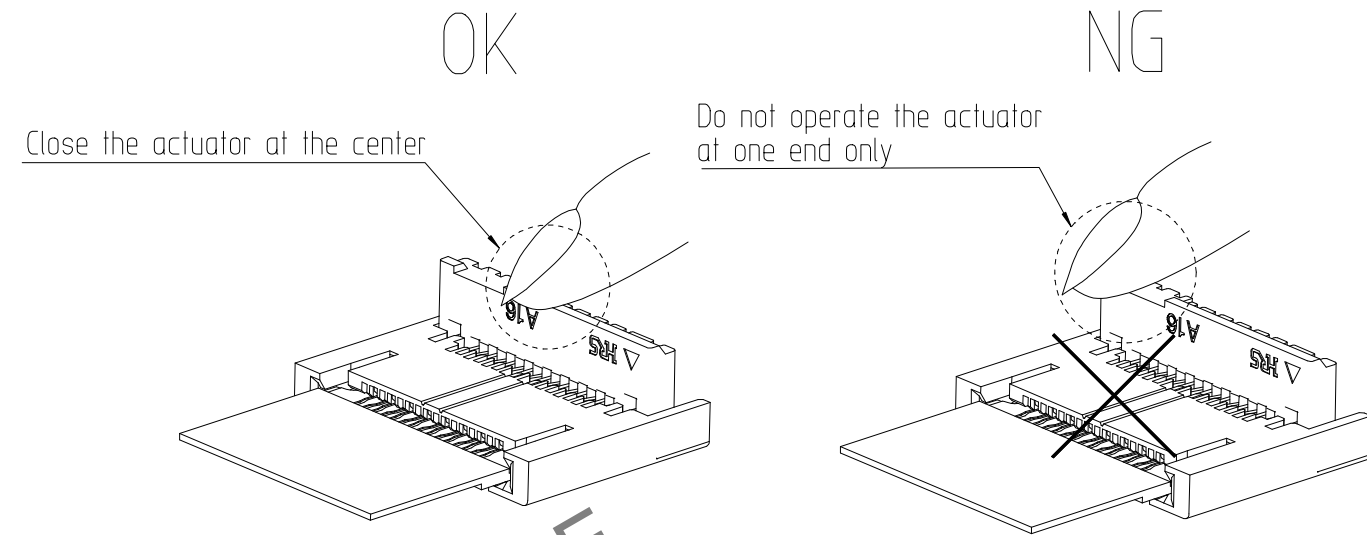
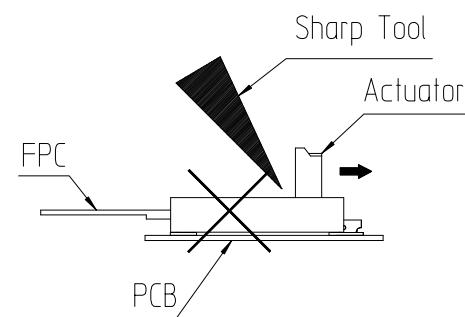

NG

Do not apply excess force to the CASE during the operation

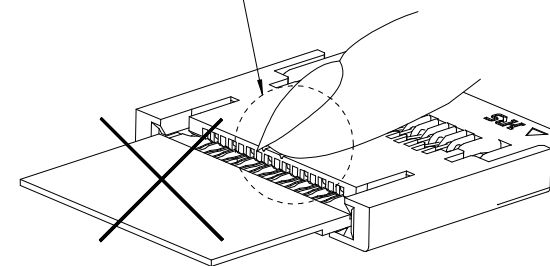

< INSTRUCTION MANUAL (2) >

Oct.1.2024 Copyright 2024 HIROSE ELECTRIC CO., LTD. All Rights Reserved.
In case of consideration for using Automotive equipment / device which demand high reliability, kindly contact our sales window correspondents.

5. How to unlock

Slowly flip up the actuator to release the lock.

[Caution]

- The actuator is opened up to the movable limit, 90 degree. Do not open the actuator beyond the specified degree or apply excess force to the actuator.
- Open the actuator right above. Do not attempt to open further or to open it by applying horizontal force as this may cause its damage.
- Please note that the connector is back flip style connector, and opening for FPC insertion and the actuator face the opposite direction. Do not try to lift the actuator at the FPC insertion opening side.
- Operate the actuator by hand without using sharp tool such as Tweezers.
- To open the actuator, operate at the center of the actuator.
- To open the actuator, do not operate the actuator at one end only.

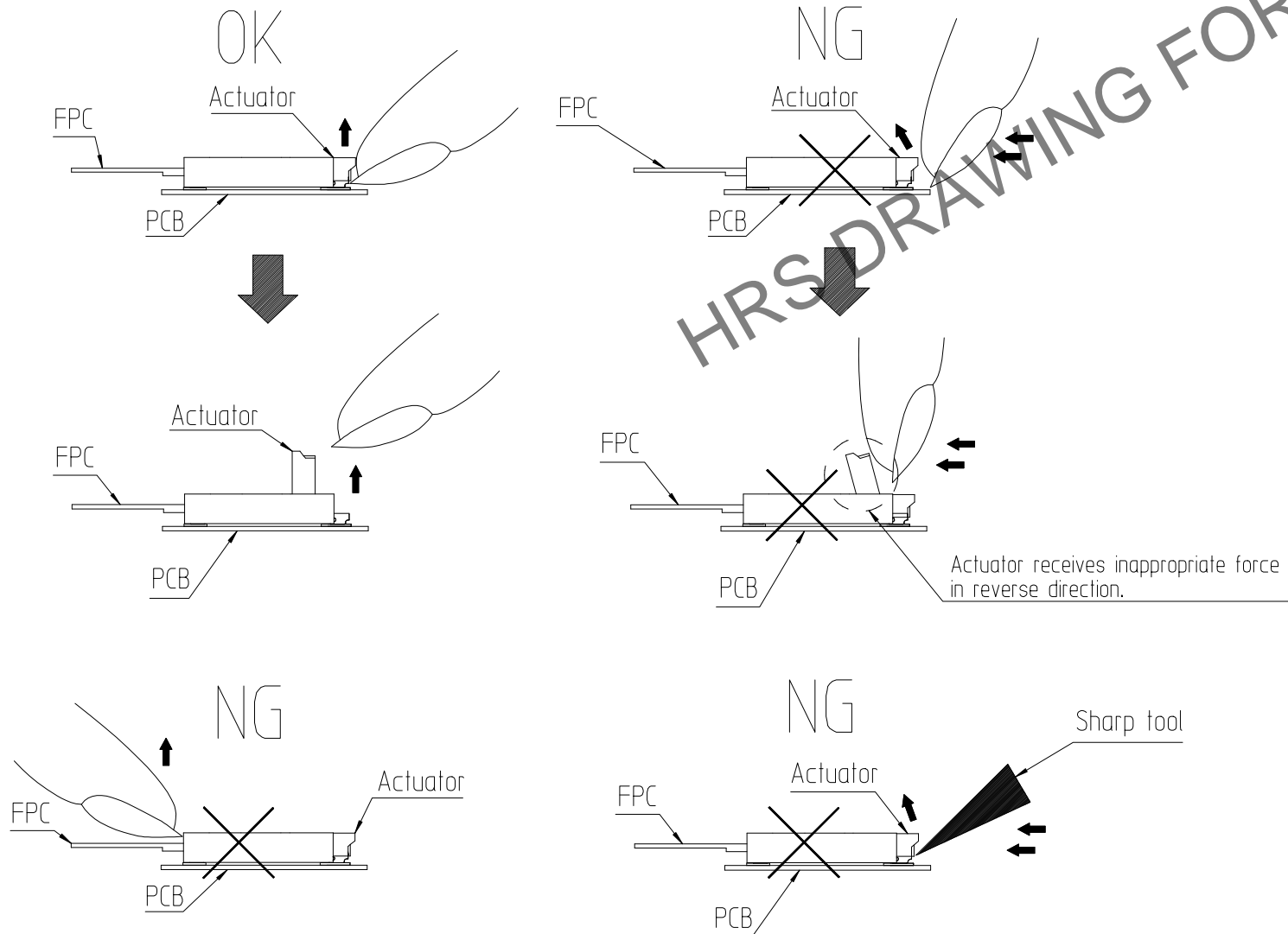

OK

Open the actuator at the center

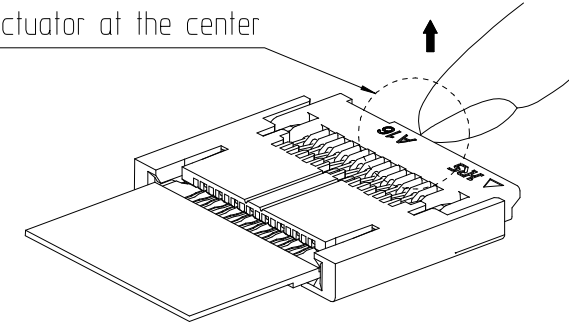

NG

Do not operate the actuator at one end only

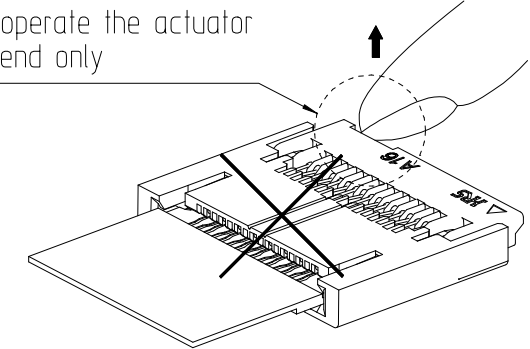

6. How to remove FPC

After rotating the actuator to the fully opened position carefully withdraw the FPC pulling out at 30 degree angle to the PCB mounting surface.

[Caution]

- This connector has a temporary FPC holding structure with chucking metals. For FPC removal, do not pull out the FPC horizontally.
- Do not attempt to pull the FPC without unlocking the actuator.

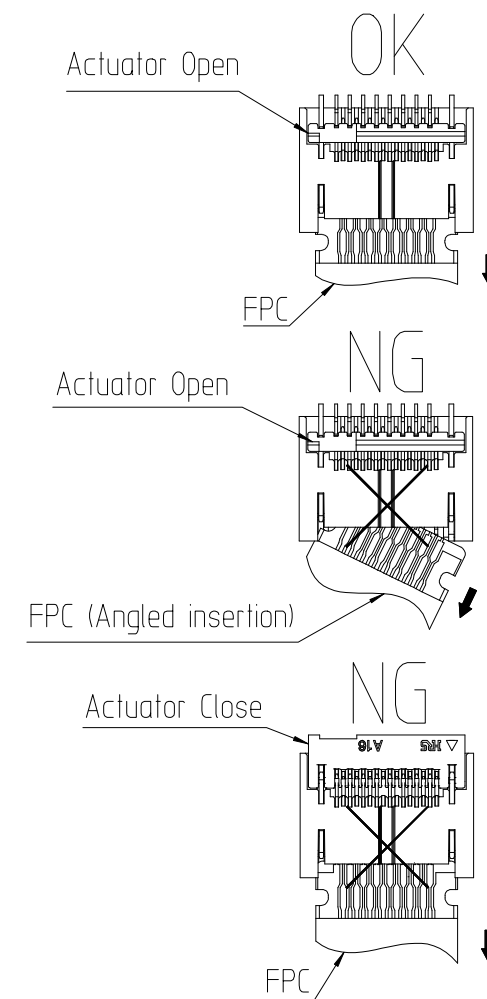
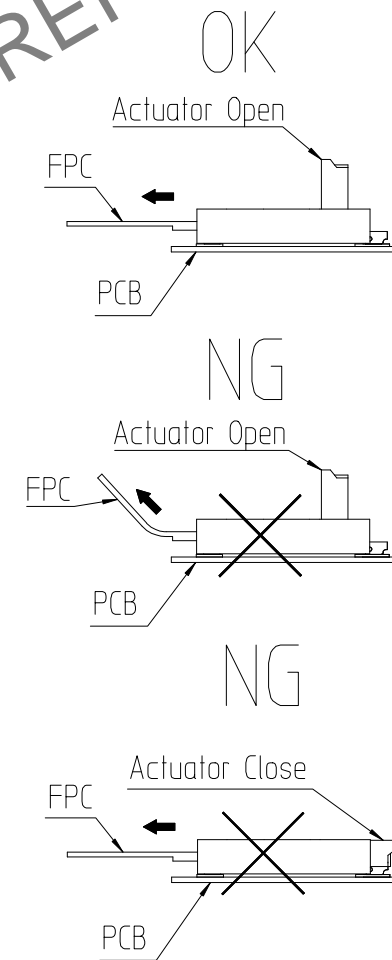

< INSTRUCTION MANUAL (3) >

Oct.1.2024 Copyright 2024 HIROSE ELECTRIC CO., LTD. All Rights Reserved.
In case of consideration for using Automotive equipment / device which demand high reliability, kindly contact our sales window correspondents.

[Precautions for design]

1. During FPC wiring, ensure that stress is not applied directly to the connector.
Do not bend the FPC excessively near the connector during use, or it may cause contact failure or FPC breakage.
Stabilizing the FPC is recommended.
2. Keep a sufficient FPC insertion space in the stage of the layout in order to avoid incorrect FPC insertion.
Appropriate FPC length and component layout are recommended for assembly ease.
Too short FPC length makes assembly difficult.
3. Follow the recommended PCB mounting pattern, stencil opening design and the FPC design.
4. Make adjustments with the FPC manufacturer for FPC bending performance and wire breakage.
5. Keep spaces for the actuator movement and its operation for PCB design and component layout.

[FPC routing after connection]

Depending on a FPC rounding, a load is applied to the connector, and a contact failure may occur.
To prevent a failure, take the following notes into a consideration during mechanism design.

[Caution]

- Avoid applying forces to FPC in vertical or horizontal directions.
In addition, avoid pulling up and down on the FPC.
- When fixing FPC after FPC cabling, avoid pulling FPC, and route the wire FPC with slack.
In this regard, the stiffener is parallel to the PCB.
- Do not mount other components touching to the FPC underneath the FPC stiffener.

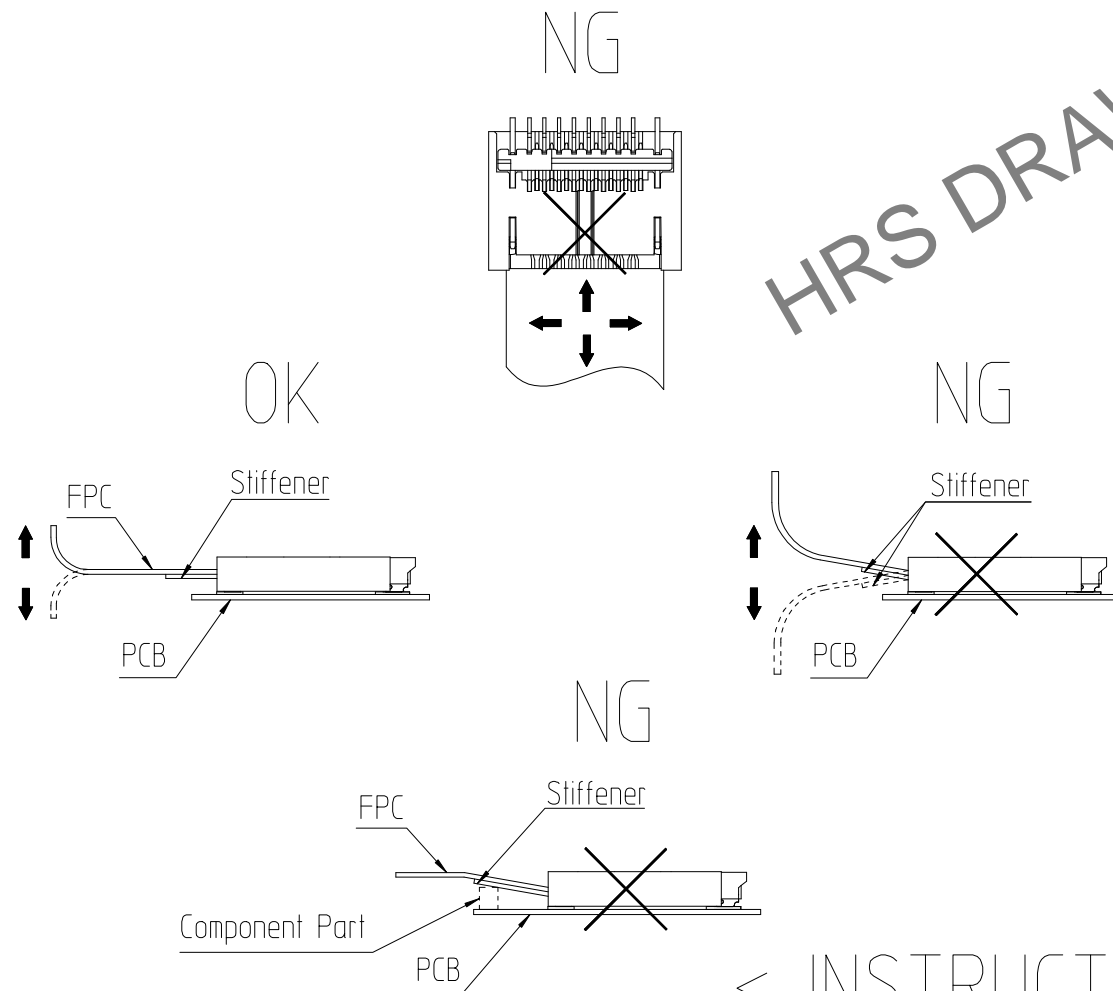

[Instructions for mounting on the PCB]

- ◆ Mounting Connector
Mounting according to the recommended PCB pattern.
If CONTACT is mounted on the PCB lock pin pad, signal connection is not possible.
- ◆ Warp of PCB
Minimize warp of the PCB as much as possible.
Lead co-planarity including reinforced chucking metals is 0.1 mm or less.
Too much warp of the PCB may result in a soldering failure.
- ◆ Flexible board design
Please make sure to put a stiffener on the backside of the flexible board.
We recommend a glass epoxy material with the thickness of 0.3mm MIN.
- ◆ Load to connector
Do not add 0.5N or greater external force when unreel or pick and place the connector etc,
or it may get broken.
In addition, do not insert the FPC or operate the connector before mounting.
- ◆ Reflow temperature profile
Apply reflow temperature profile within the specified conditions.
In individual applications, the actual temperature may vary,
depending on solder paste type, volume/thickness and PCB size/thickness.
Consult your solder paste and equipment manufacturer for specific recommendations.

[INSTRUCTIONS FOR PCB HANDLING AFTER MOUNTING THE CONNECTOR]

- ◆ Load to PCB
 - Splitting a large PCB into several pieces
 - Screwing the PCBAvoid the handling described above so that no force is exerted on the PCB during the assembly process.
Otherwise, the connector may become defective.
- ◆ Amount of Warp
The warp of a 100mm wide PCB should be 0.5 mm or less.
The warp of PCB suffers stress on connector and the connector may become defective.

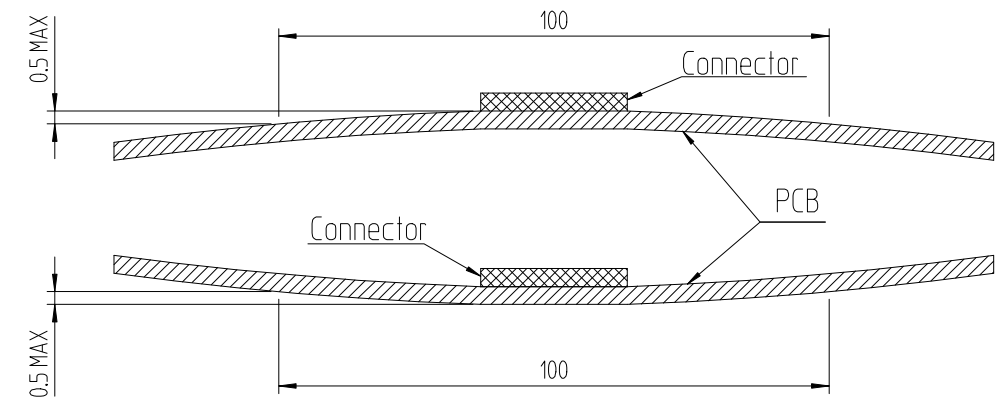

[Other instructions]

- ◆ Instructions on manual soldering
Follow the instructions shown below when soldering the connector manually during repair work, etc.
 1. Do not perform manual soldering with the FPC inserted into the connector.
 2. Do not heat the connector excessively. Be very careful not let the soldering iron contact any parts other than connector leads. Otherwise, the connector may be deformed or melt.
 3. Do not supply excessive solder (or flux).
If excessive solder (or flux) is supplied on the terminals, solder or flux may adhere to the contacts or rotating parts of the actuator, resulting in poor contact or a rotation failure of the actuator.
Supplying excessive solder to the chucking metals may hinder actuator rotation, resulting in breakage of the connector.