

Jan.1.2025 Copyright 2025 HIROSE ELECTRIC CO., LTD. All Rights Reserved.
 In case of consideration for using Automotive equipment / device which demand high reliability, kindly contact our sales window correspondents.

△數 COUNT	訂正事項 DESCRIPTION OF REVISIONS	擔當 B	檢圖 CHKD	年月日 DATE	△數 COUNT	訂正事項 DESCRIPTION OF REVISIONS	擔當 B	檢圖 CHKD	年月日 DATE
2	Released(RE-2-2440)	KYG	LHJ	23. 10. 26					
-	EC(RE-2-2477)	KYG	LHJ	23. 12. 08					
1	EC(RE-2-2556)	KJH	LHJ	24. 05. 01					

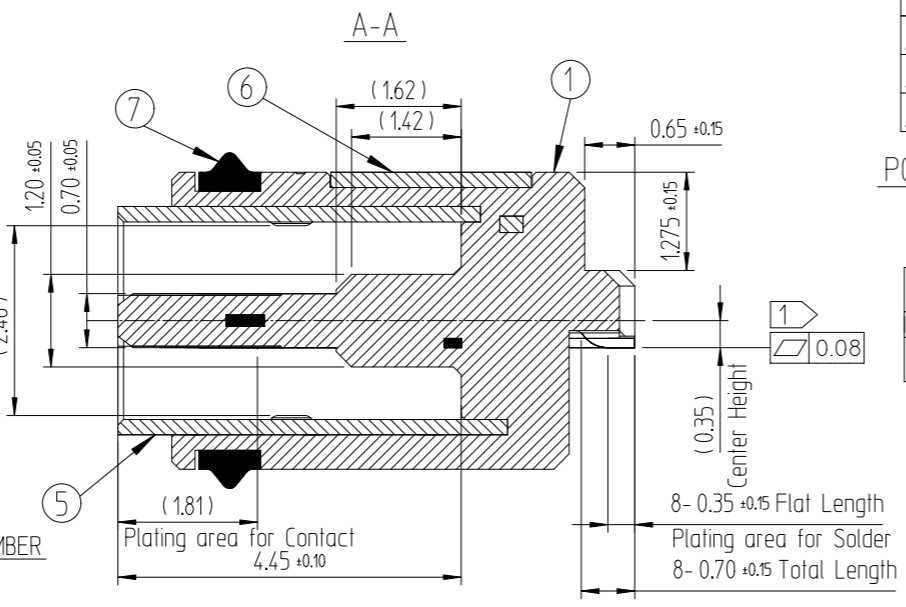

PCB MOUNTING POSITION

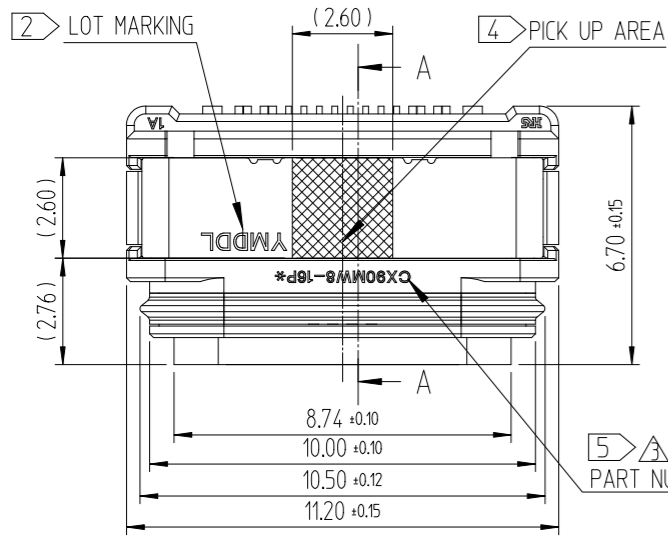
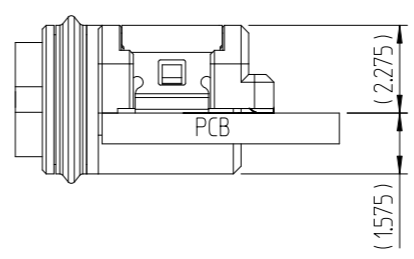

ISO-VIEW

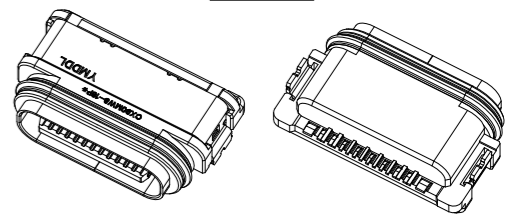

RECOMMENDED PCB LAYOUT(TOP-VIEW)
 (GENERAL TOLERANCE : ±0.05)

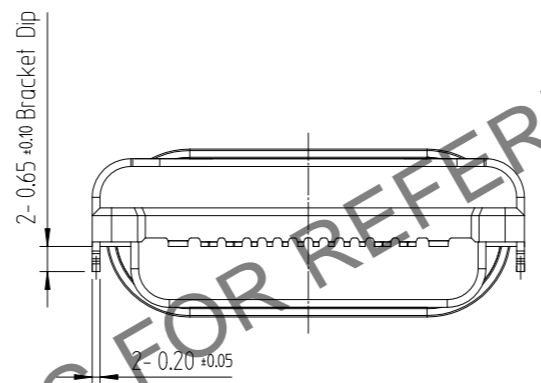
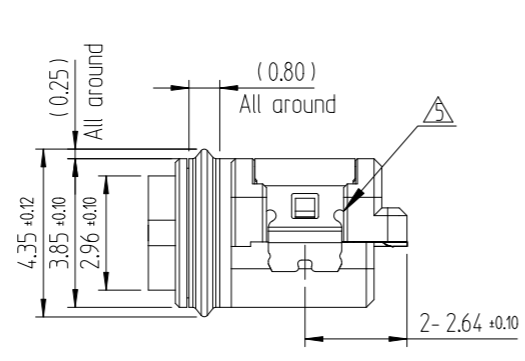
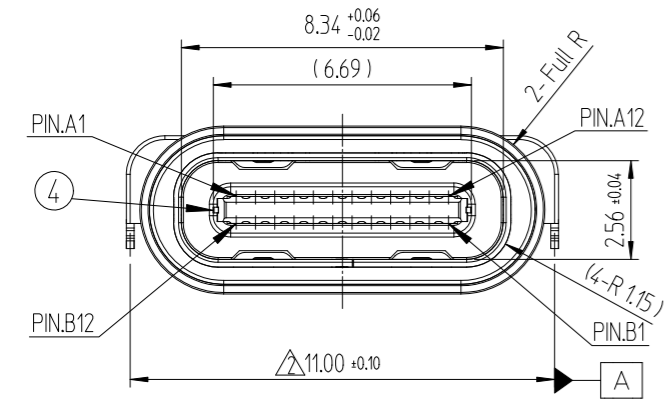
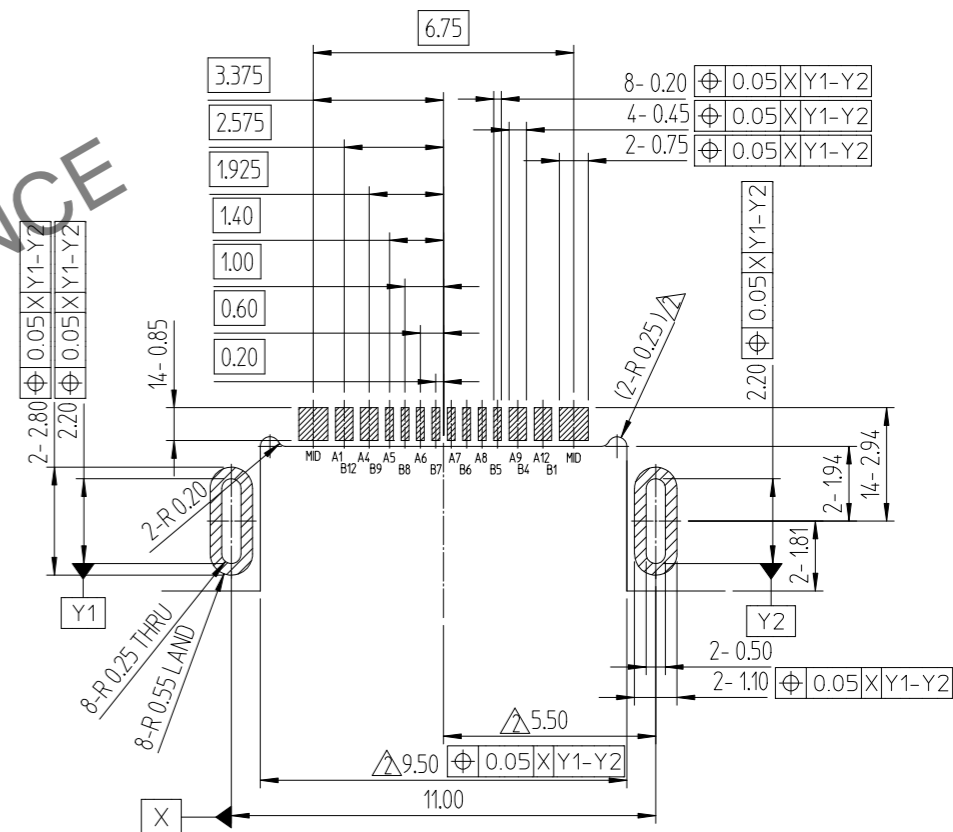

Recommended Set design (Referance)

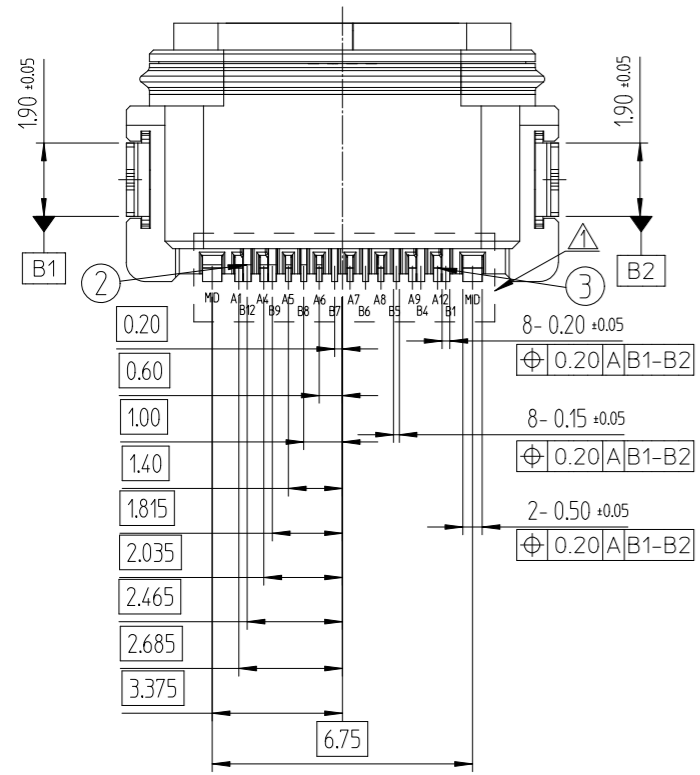
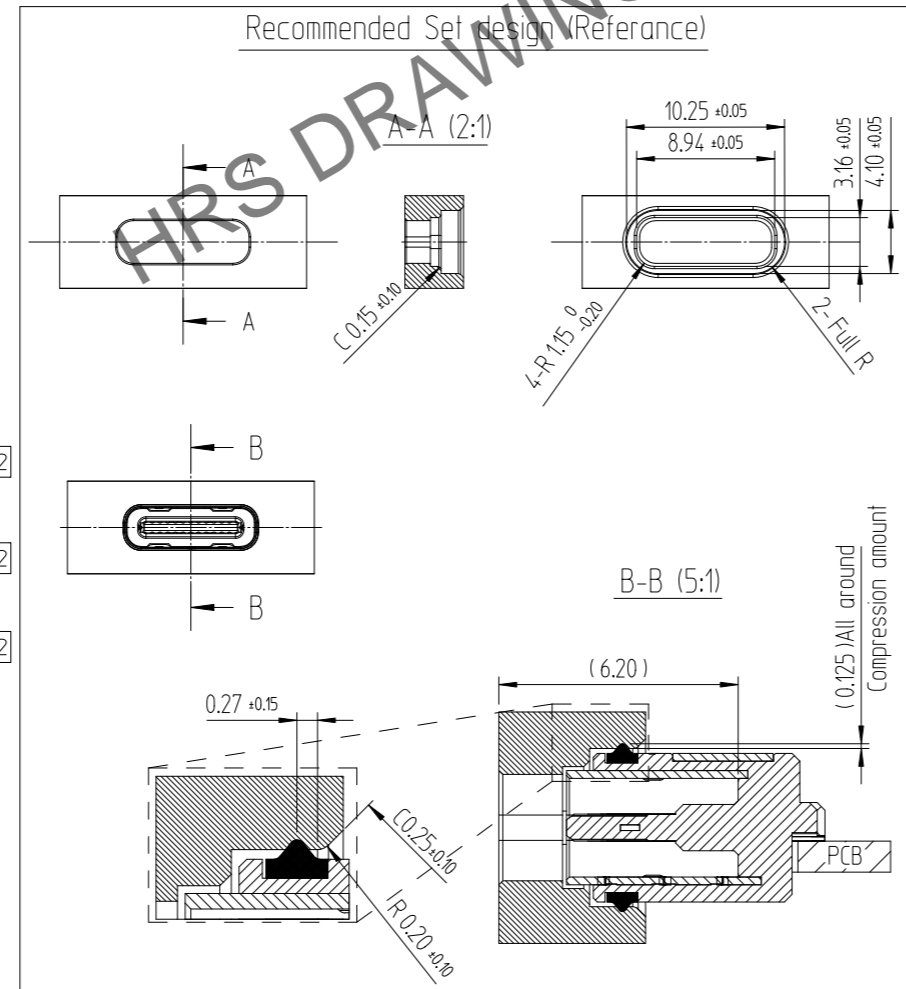

NO.	DESCRIPTIONS	MATERIAL	FINISH	REMARKS
7	GASKET	SILICONE	GRAY COLOR	-
6	BRACKET	STAINLESS STEEL	NICKEL PLATING	-
5	SHELL	STAINLESS STEEL	CLENSING	-
4	MID PLATE	STAINLESS STEEL	SOLDER AREA : GOLD OVER NICKEL PLATING THE OTHER AREA : NICKEL PLATING	-
3	CONTACT 2ND	COPPER ALLOY	CONTACT AREA : GOLD OVER NICKEL PLATING SOLDER AREA : GOLD OVER NICKEL PLATING	-
2	CONTACT 1ST	COPPER ALLOY	THE OTHER AREA : NICKEL PLATING	-
1	INSERT CASE	THERMOPLASTIC	BLACK COLOR	UL94V-0

CODE NO. (OLD)	DRAWN	DESIGNED	CHECKED	APPROVED	RELEASED
	Y.G.KIM 22.06.20	Y.B.PARK 22.06.20	H.J.LEE 22.06.20	H.J.LEE 22.06.20	ENG 24.05.01 DEPT

DRAWING NO.	PART NO.
EDC3-633692-00	CX90MW8-16P*

SCALE	UNITS	CODE NO.
5:1	mm	CL ****-****-****

HRS DRAWING FOR REFERENCE

Jan.1.2025 Copyright 2025 HIROSE ELECTRIC CO., LTD. All Rights Reserved.
In case of consideration for using Automotive equipment / device which demand high reliability, kindly contact our sales window correspondents.

DRAWING FOR PACKING

DIRECTION OF UNREELING →

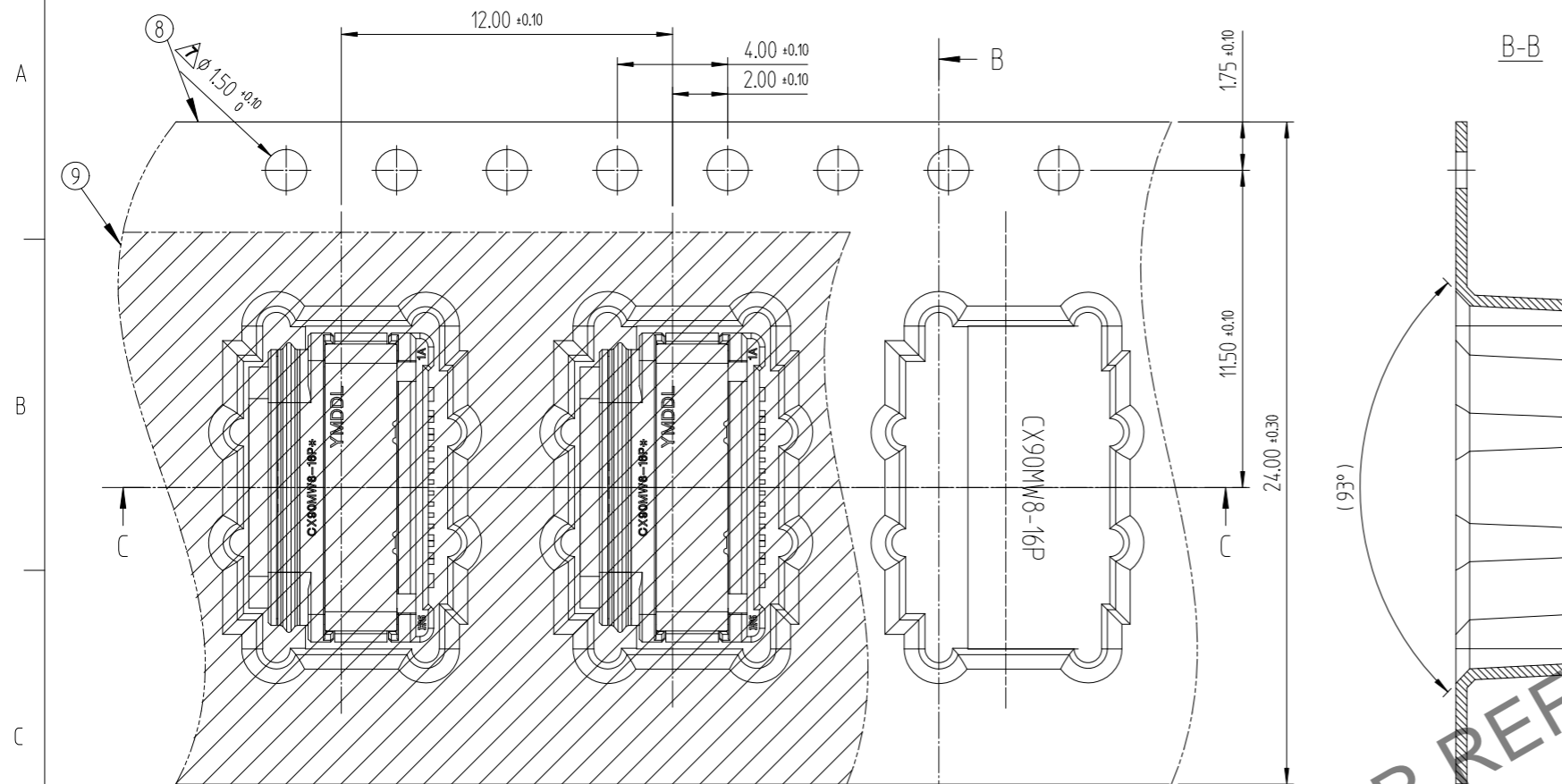

B-B

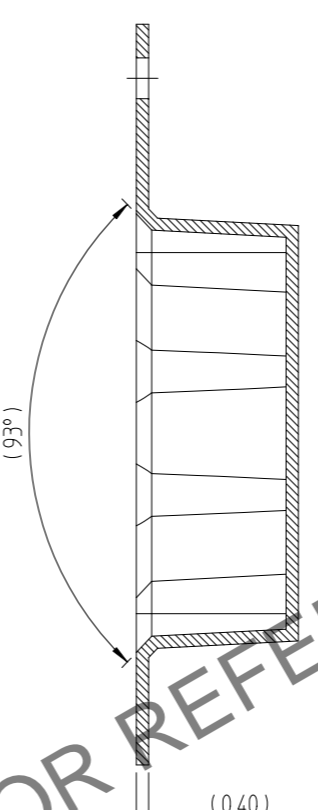

[NOTE]

- ① Co-planarity of contact leads.
- 0.08max.before reflow, 0.10max.after reflow 2times and during reflow.
- ② Lot marking : 5 digits (YMDDL)

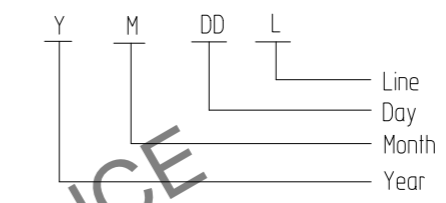

[Chart-1] LOT MARKING

Year	Month	Day	Production Line
2020	0	Jan. 1	1st 01 Sample
2021	1	Feb. 2	2nd 02 MP Manual#1
2022	2	Mar. 3	3th 03 MP Manual#2
2023	3	Apr. 4	4th 04 MP Manual#3
2024	4	May 5	5th 05 MP Manual#4
2025	5	Jun. 6	6th 06 ...
2026	6	Jul. 7	7th 07 MP Auto#1
2027	7	Aug. 8	8th 08 MP Auto#2
2028	8	Sep. 9	9th 09 MP Auto#3
2029	9	Oct. A	10th 10 MP Auto#4
		Nov. B	11th 11 MP Auto#5
		Dec. C

PIN ASSIGNMENT(FRONT-VIEW)

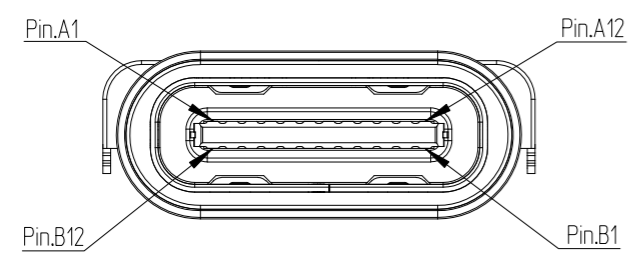

A1	A2	A3	A4	A5	A6	A7	A8	A9	A10	A11	A12
GND		Vbus	CC1	D+	D-	SBU1	Vbus				GND
B12	B11	B10	B9	B8	B7	B6	B5	B4	B3	B2	B1
GND		Vbus	SBU2	D-	D+	CC2	Vbus				GND

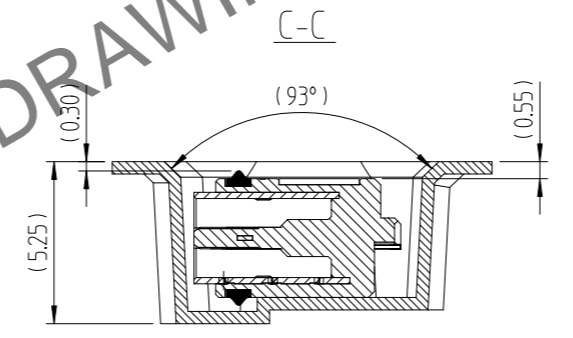

3. Carrier tape packing

Packing quantity : 1,400EA/REEL

Cover tape peeling force : 10~130gf(0.1~1.3N) @ 300mm/min

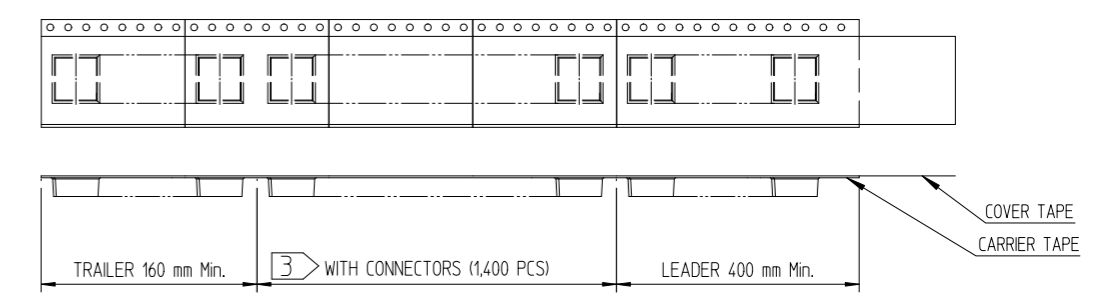

④ Pickup area

⑤ Series P/N Marking

No.	P/N	Marking	Code No.	Description
1	CX90MW8-16P	CX90MW8-16P	CL 6249-0009-8-000	IP54, Air leak Full-inspection
2	CX90MW8-16P1	CX90MW8-16P1	CL 6249-0013-5-000	IP68, Air leak Full-inspection

LABEL POSITION

PULL OUT DIRECTION →

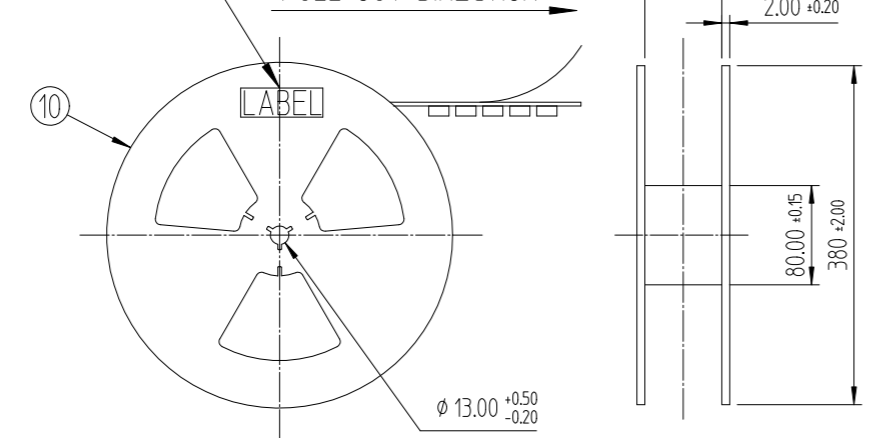

10	REEL BOBBIN	PS	-	
9	COVER TAPE	PET	-	
8	EMBOSS TAPE	PS	Thermo-Comperssion Sealing	
NO.	DESCRIPTIONS	MATERIAL	FINISH	REMARKS
	DRAWING NO. EDC3-633692-00		PART NO. CX90MW8-16P*	
SCALE	5:1		CODE NO. CL ****-****-***	
UNITS	mm		HRS HIROSE KOREA CO.,LTD. 2/2	