

1. Scope

This document specifies the steps from crimping the DF11-series crimped terminals to cables (AWG22 - AWG30) to inserting the terminals to crimping sockets the DF51-series.

2. Connectors

■ Crimping cases

DF51 - * S-2C

- ① ② ③ ④ ⑤



①	Name: DF51
②	No. of contacts: Single-row : 2-7  Double-row : 4-30
③	Connector types S : Single-row socket DS : Double-row socket EP : Single-row in-line plug DEP : Double-row in-line plug
④	Contact pitch: : 2 mm
⑤	Shape of connection/terminal C: Crimping case

■ Crimped terminals

DF11 - EP 2428 PCF A

- ① ② ③ ④ ⑤

①	Name: DF11
②	Connector types EP: In-line plug
③	Compatible cables 22 : AWG 22 2428 : AWG 24 - 28 30 : AWG 30
④	Shape/packing SCF : Socket terminal, reeled SC : Socket terminal, separate PCF : Plug terminal, reeled PC : Plug terminal, separate
⑤	Plating Blank : Tin plating A : Gold plating

COUNT	DESCRIPTION OF REVISIONS	DESIGNED	CHECKED	DATE	
 1	DIS-H-00014544	KI. SUGAWARA	TT. OHSAKO	20220713	
TITLE		 HIROSE ELECTRIC CO., LTD.			
DF51 Series Cable Assembly Procedure					
APPROVED	HS. OKAWA				20180704
CHECKED	SZ. ONO				20180704
DESIGNED	TS. MIYAKI	20180704			
WRITTEN	TS. MIYAKI	20180704			
TECHICAL SPECIFICATION		ETAD-H0923-00		1 / 6	

3. Steps for harnessing

3.1. Cable stripping

Strip cables in accordance with Crimping Quality Standards (ATAD-H0773/ATAD-H0935). In so doing, make sure there is no scratch on cable cores.

3.2. Crimping

Crimped terminals to cables using an applicator (AP105-DF11-*****), and check the crimping height and shape in accordance with the Table of crimping conditions and Crimping Quality Standards (ATAD-H0773/ATAD-H0935).

3.3. Insertion to crimping terminal sockets

Hold the cable of a crimped terminal, and insert it to each terminal hole of crimping sockets. (Insert the terminal in the direction of arrows below.)

*The figures show insertion to DF51-16DS-2C and DF51-16DEP-2C.

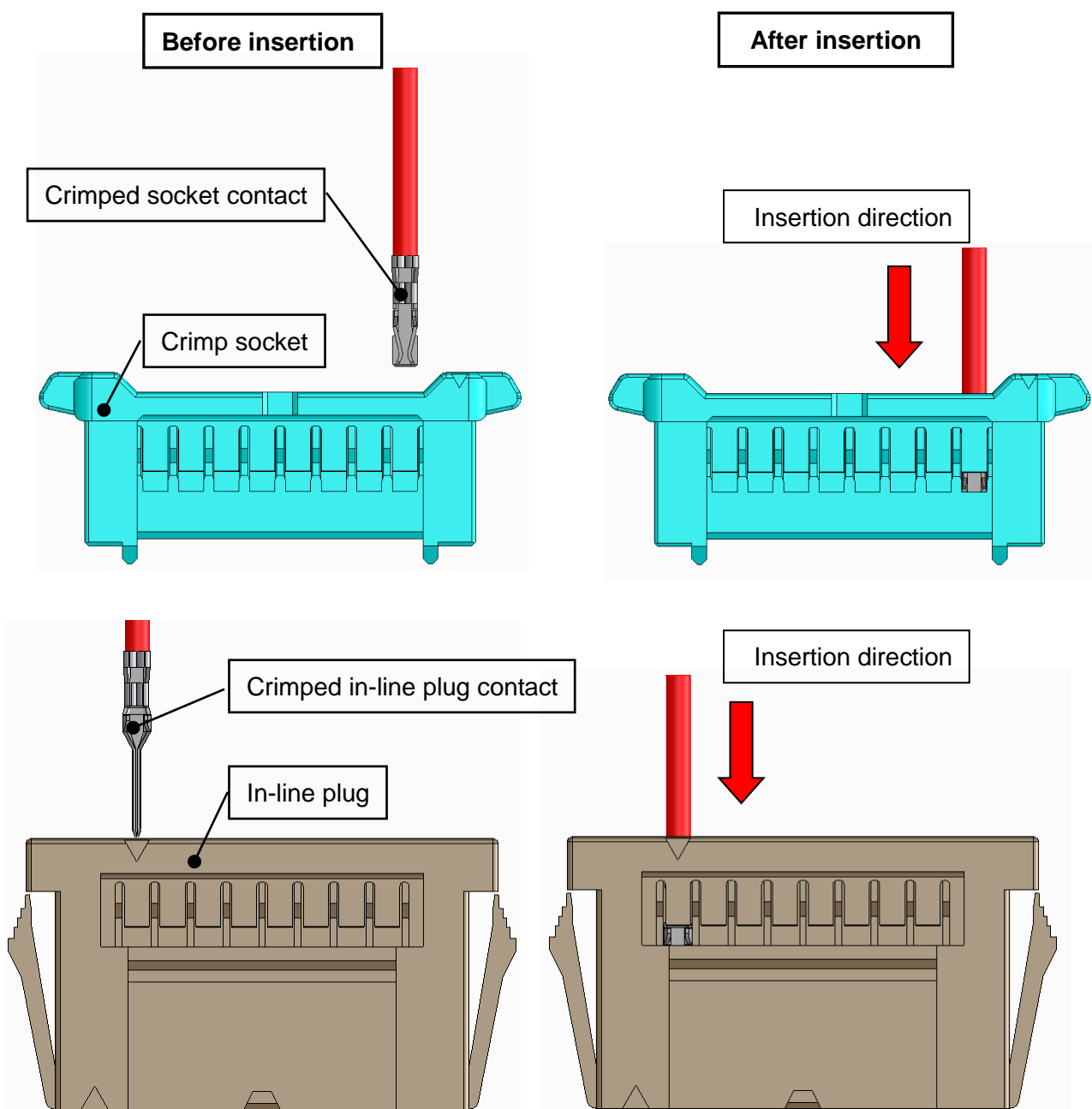

- For insertion, place the crimped terminal and crimping socket lock in the following direction:

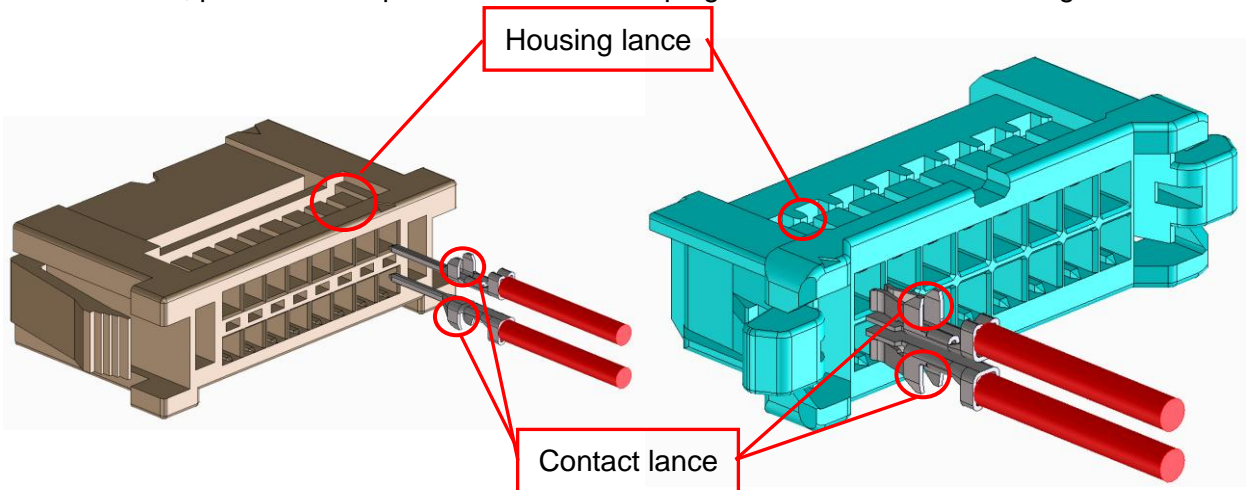

- To maintain performance reliability, do not tilt crimped terminals for insertion.

**Horizontal insertion
(Correct)**

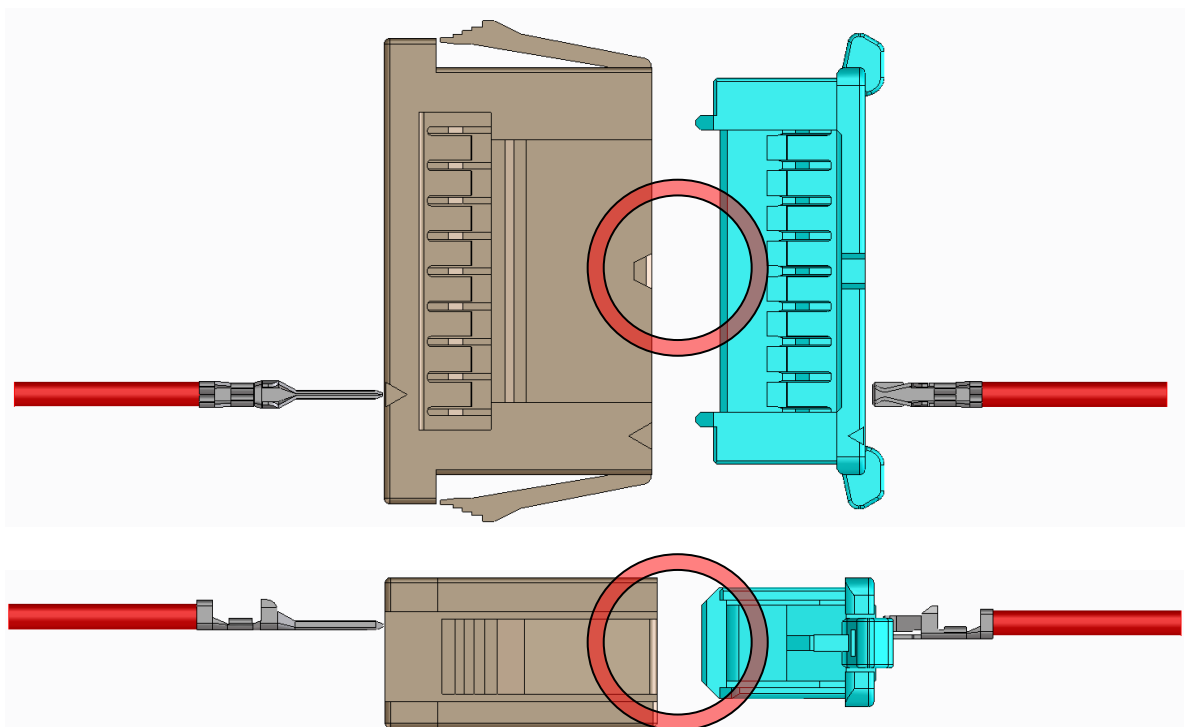

**Tilted insertion
(Incorrect)**

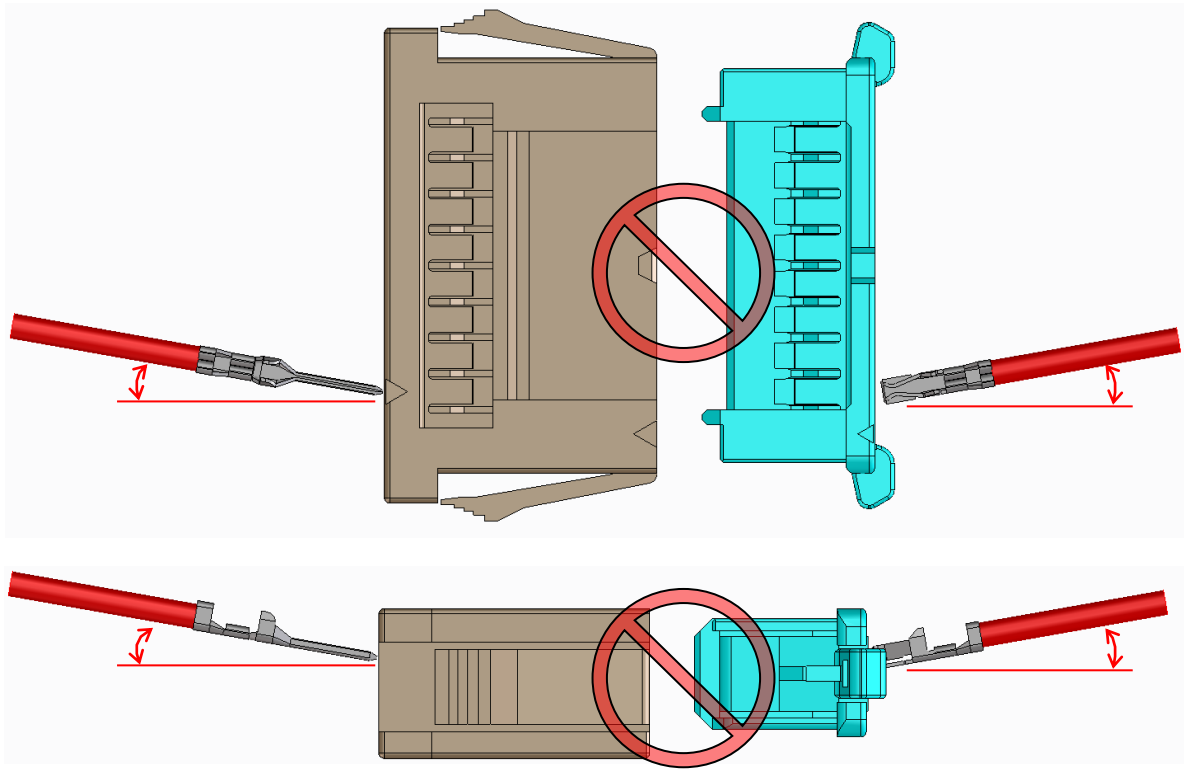

Confirmation of inserted contact conditions

Make sure that the contact lance is caught by the housing lance of the crimp socket.
(Visual check or Slightly pull the terminal to check.)

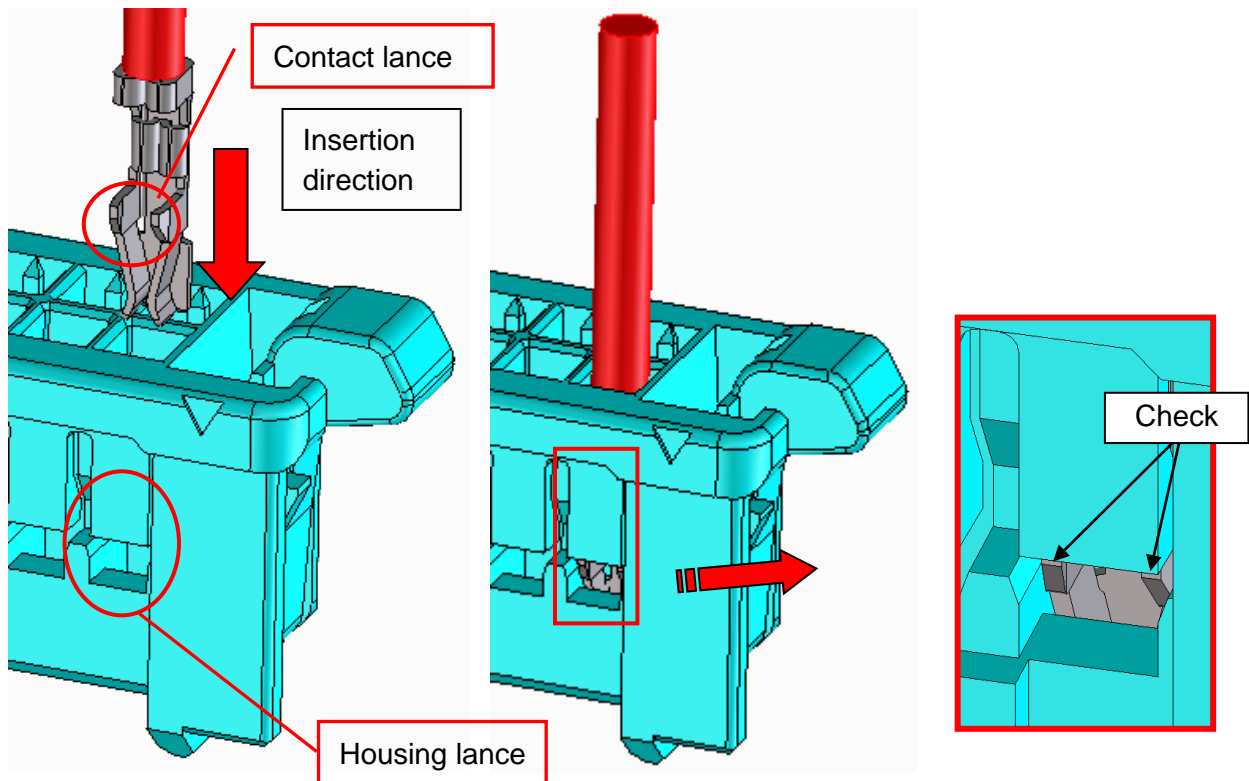

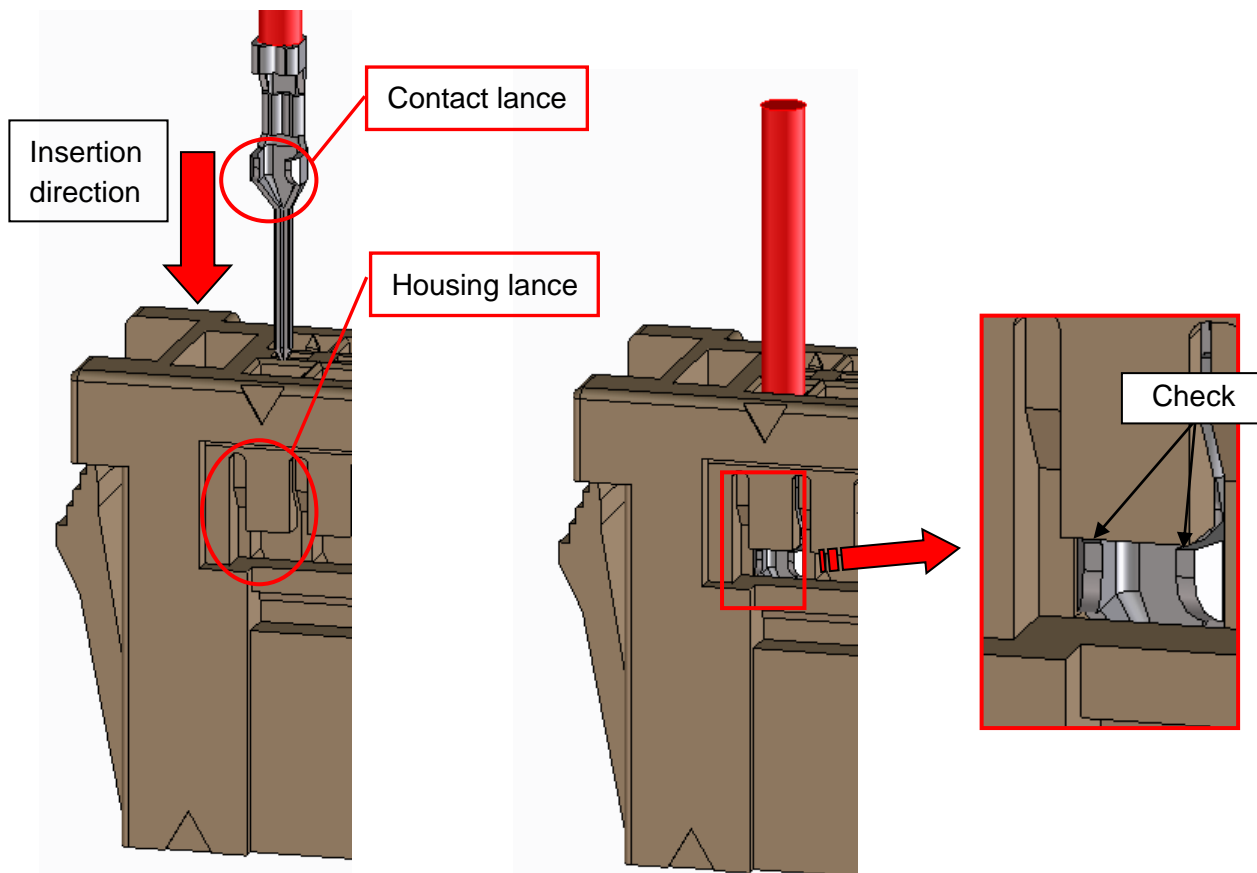

NOTE: Repairing the crimp contact

For removing the inserted contact form socket, lift up the housing lance by using DF-C-PO(B) or a pointed needle, and pull out the cable simultaneously. The repair operation could make the lance strength lower, therefore, please do not reuse the repaired crimp socket and replace it to a new one.

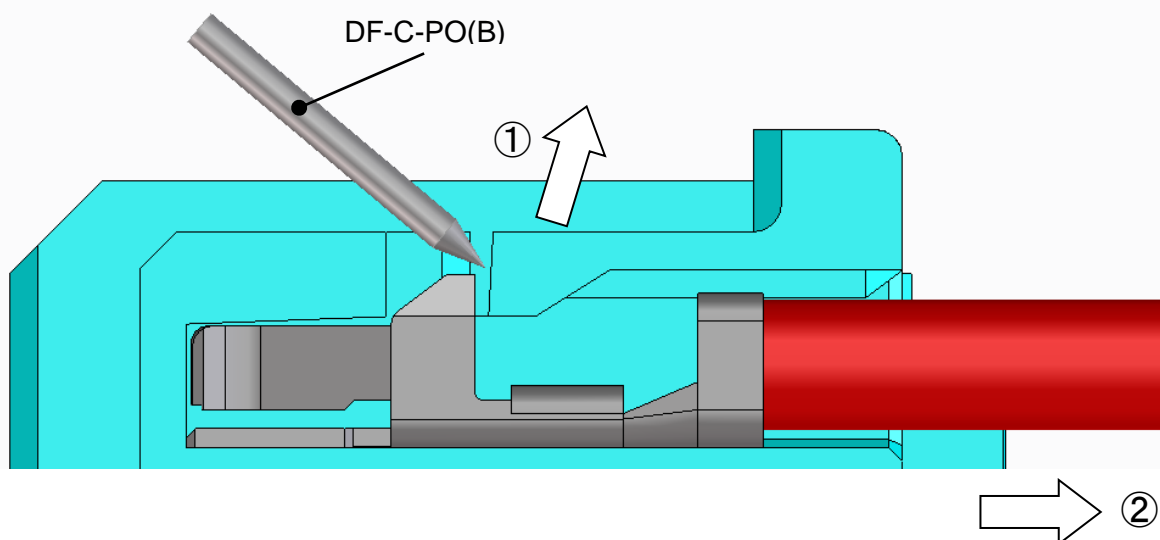

4. Precautions for handling

4.1. Packing and storage

To pack or store assemblies, make sure overlapped connectors will not apply extreme load to the lock section.

If load is applied to the lock section under high temperature and humidity for a long period of time, the lock section will be deformed which could lead poor fitting.

4.2. Loading to a connector

To pack or store assemblies, make sure overlapped connectors will not apply extreme load to excessive external force applied to connectors could cause failure or damage. Therefore, avoid forced insertion or removal, dropping impact, cable wiring (pull, twist) and such.

4.3. Wiring cable

During cable wiring inside the machine, keep sufficient cable length for slack to avoid direct stress is applied to the connector.

Forcible wiring such as bending the cable near the connector and straining the cable, could cause contact failure and / or waterproof defect.

