

Jun.1.2026 Copyright 2026 HIROSE ELECTRIC CO., LTD. All Rights Reserved.
 In case of consideration for using Automotive equipment / device which demand high reliability, kindly contact our sales window correspondents.

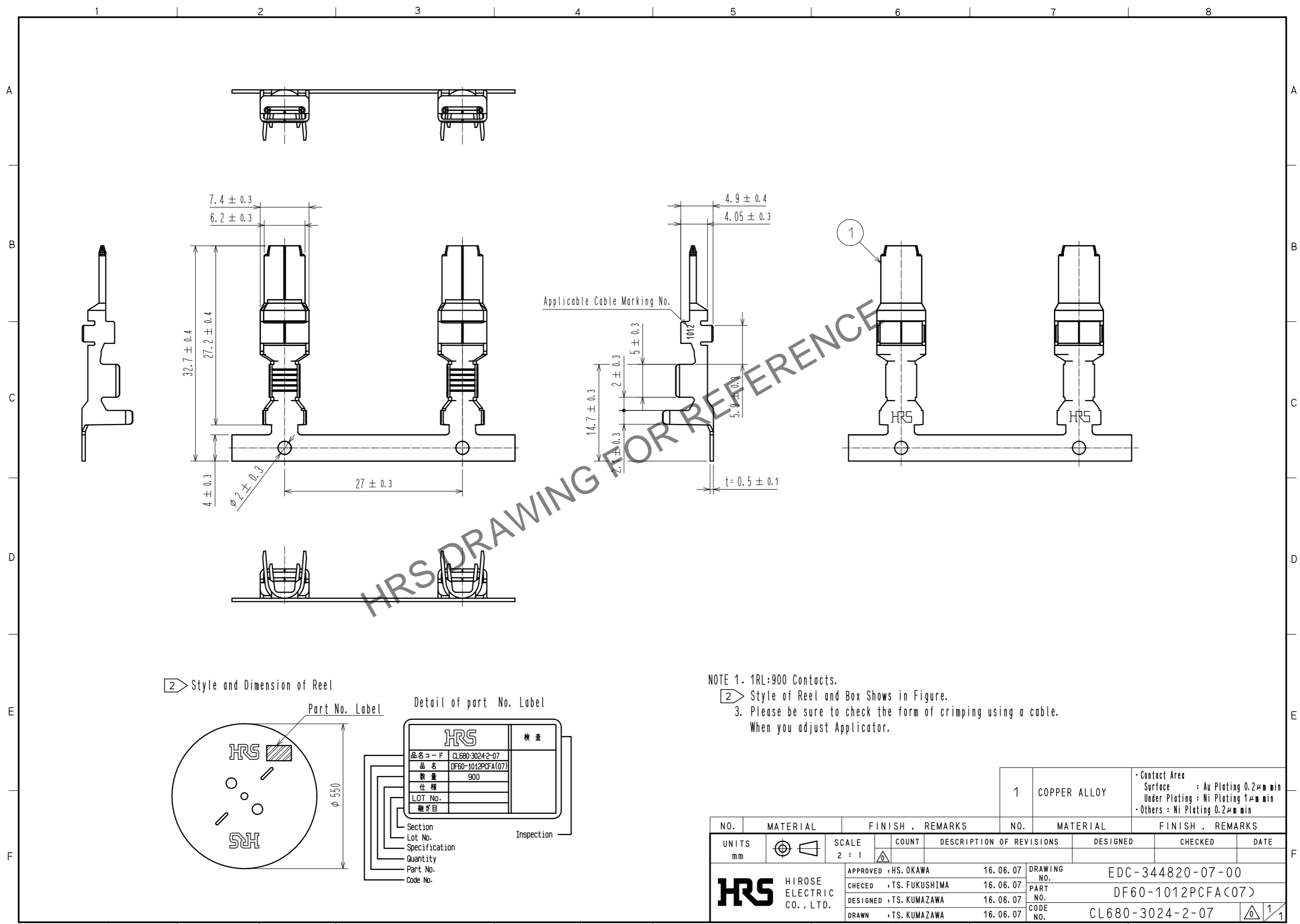

2 Style and Dimension of Reel

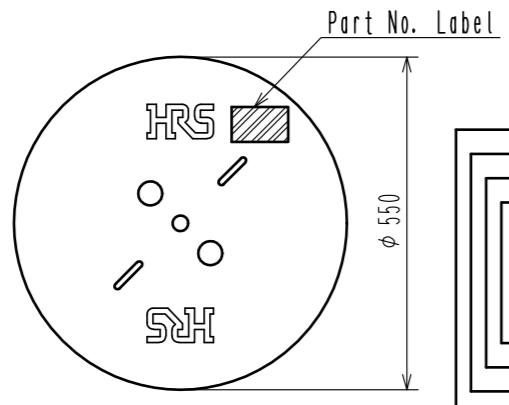

Detail of part No. Label

HRS		検査
品名コード	CL680-3024-2-07	
品名	DF60-1012PCFA(07)	
数量	900	
仕様		
LOT No.		
継ぎ目		

Section
 Lot No.
 Specification
 Quantity
 Part No.
 Code No.

Inspection

- NOTE 1. 1RL:900 Contacts.
 2 Style of Reel and Box Shows in Figure.
 3. Please be sure to check the form of crimping using a cable.
 When you adjust Applicator.

NO.	MATERIAL	FINISH . REMARKS	NO.	MATERIAL	FINISH . REMARKS		
1	COPPER ALLOY				· Contact Area Surface : Au Plating 0.2μm min Under Plating : Ni Plating 1μm min · Others : Ni Plating 0.2μm min		
UNITS mm		SCALE 2 : 1	COUNT	DESCRIPTION OF REVISIONS	DESIGNED	CHECKED	DATE
HRS HIROSE ELECTRIC CO., LTD.		APPROVED : HS. OKAWA	16.06.07	DRAWING NO.	EDC-344820-07-00		
		CHECED : TS. FUKUSHIMA	16.06.07	PART NO.	DF60-1012PCFA(07)		
		DESIGNED : TS. KUMAZAWA	16.06.07	CODE NO.	CL680-3024-2-07		
		DRAWN : TS. KUMAZAWA	16.06.07		1/1		