

DF60F In-Line Type Recommended Panel Mounting Manual in Using Nuts

Nut insertion process

1. Slide the nut (size:M3) to the nut fix part.

2. Press down the nut until it clicks.
Then, this sound means that the nut has inserted into the nut holder.

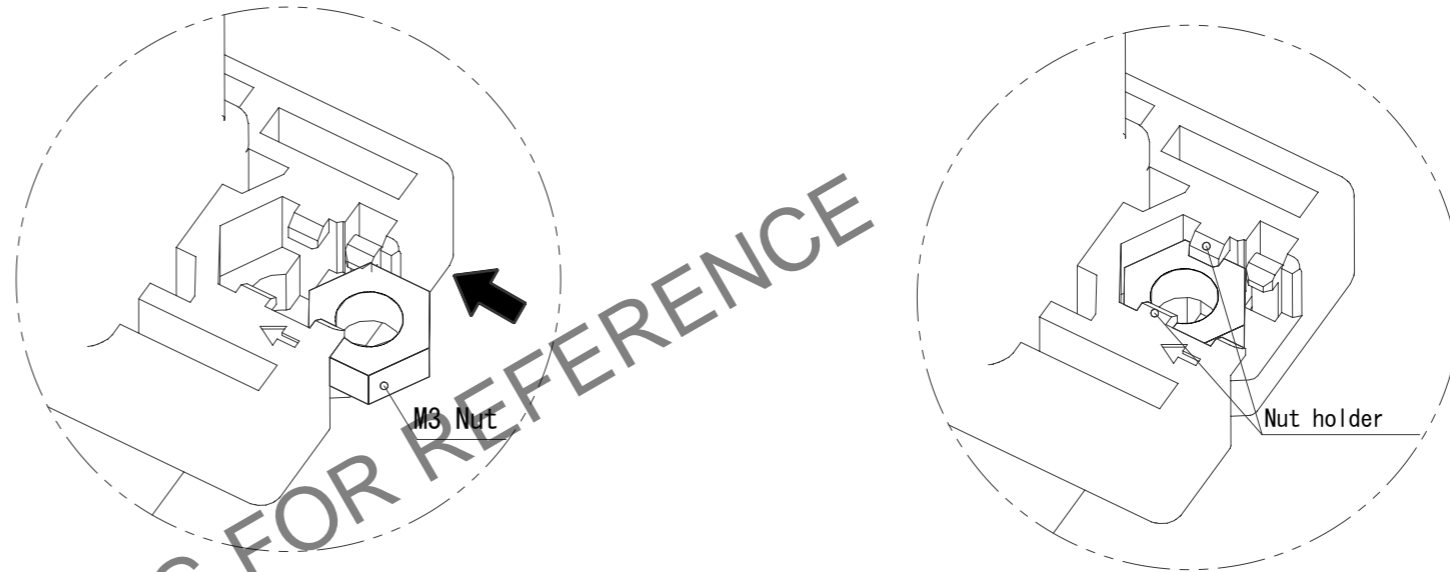
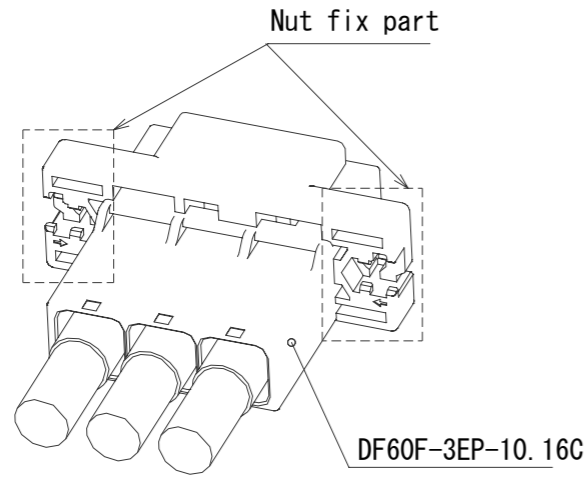

Panel mounting process

1. Insert connector into the panel cut out part.

2. Tighten a screw (size:M3) to fix with panel.
Recommended torque : Less than 0.49N · m

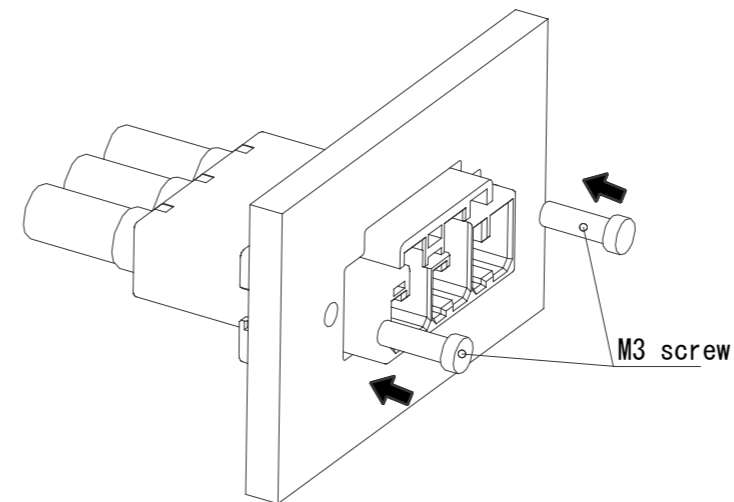
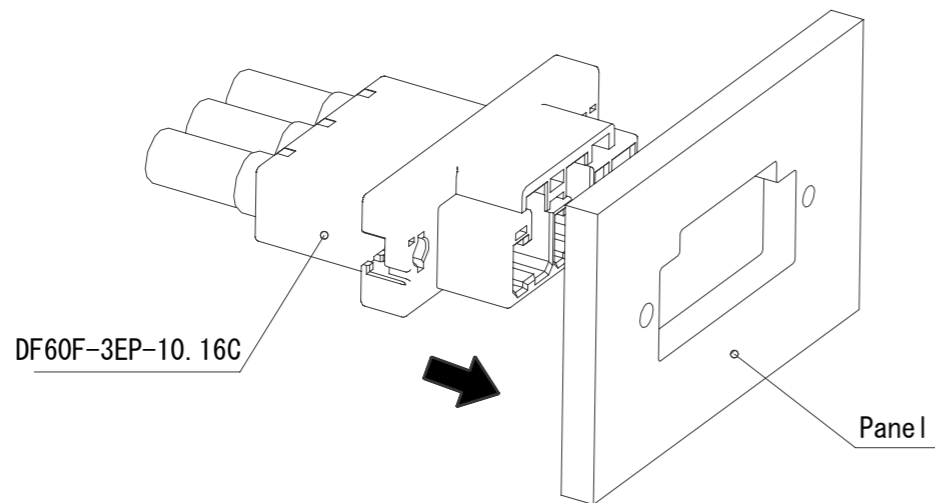

HRS	DRAWING NO.	EDC-405515-00-00	2/2
	PART NO.	DF60F-4EP-10.16C	
	CODE NO.	CL0680-4023-0-00	
	NO.		

Jun.1.2026 Copyright 2026 HIROSE ELECTRIC CO., LTD. All Rights Reserved. In case of consideration for using Automotive equipment / device which demand high reliability, kindly contact our sales window correspondents.