

ELV, RoHS COMPLIANT

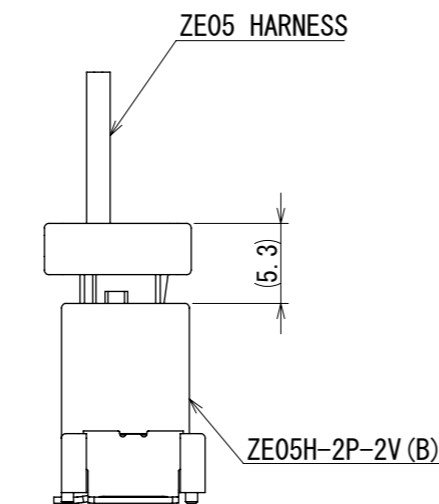

RECOMMENDED PCB PATTERN

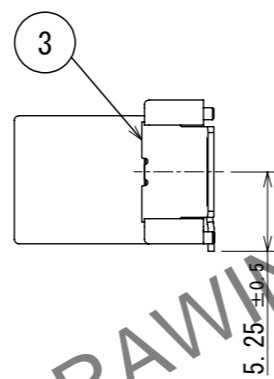
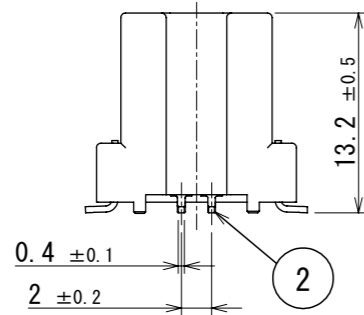
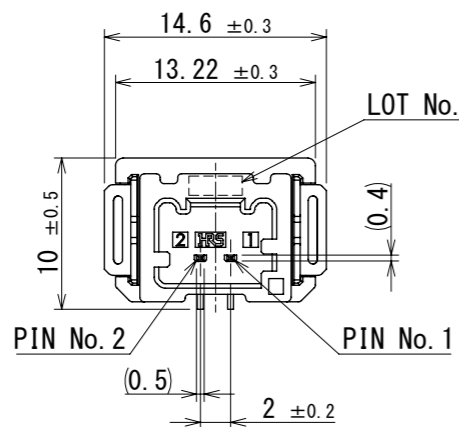
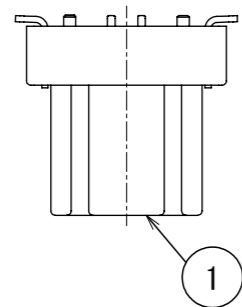
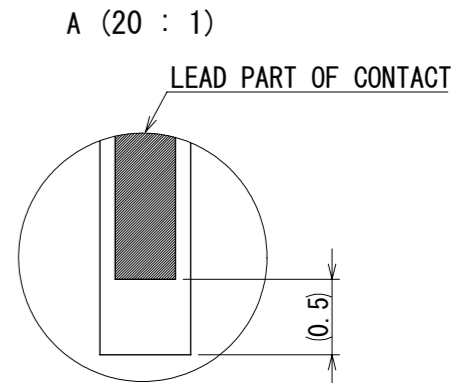
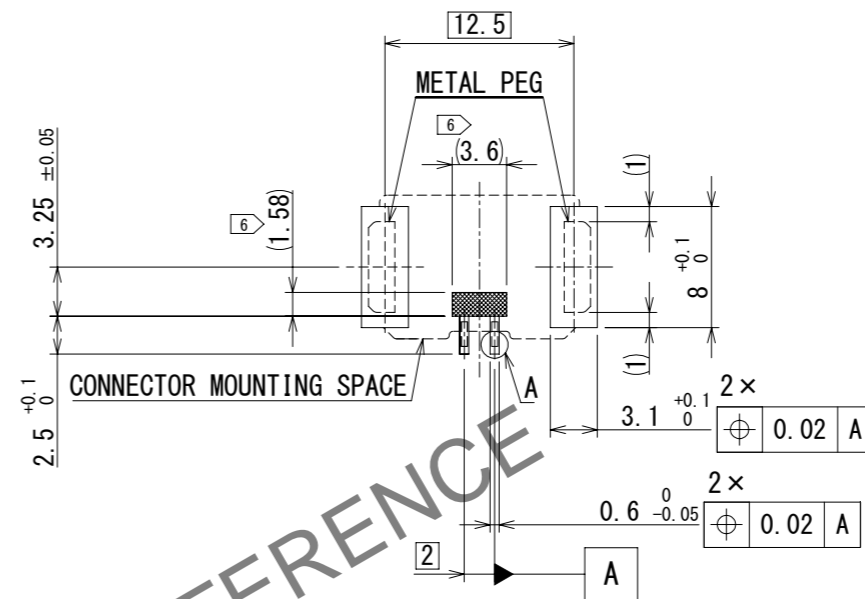

HRS DRAWING FOR REFERENCE

- NOTE 1. RECOMMENDED TEMPERATURE PROFILE FOR REFLOW (REFER TO RIGHT FIG.) USED REFLOW SYSTEM
- NO. OF CYCLES : 2 MAX
 - PEAK : 250°C
 - OVER 230°C : 20~40s
 - PREHEAT : 150~180°C
 - 90~120s
2. TEMPERATURE FOR SOLDERING IRON : 280~300°C WITHIN 2s
3. CO-PLANARITY SHALL BE 0.1mm MAX.
4. RECOMMENDED PCB THICKNESS IS 1.6mm.
5. RECOMMENDED SOLDER THICKNESS IS 0.15mm.
6. [Hatched Box Symbol] : PROHIBITED PATTERN AREA

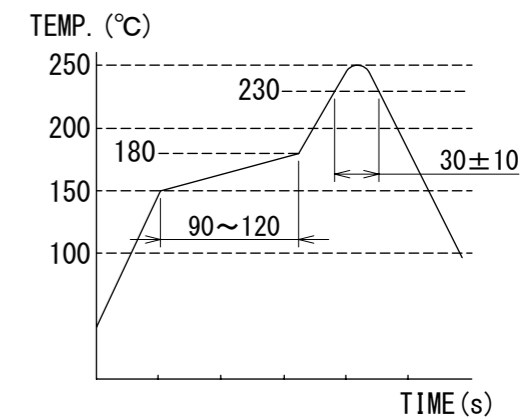

3	BRASS	SURFACE PLATING : TIN PLATING 1μm min					
		UNDER PLATING : NICKEL 1μm min					
2	BRASS	SURFACE PLATING : TIN PLATING 1μm min	6	POLYIMIDE	PICK & PLACE TAPE		
		UNDER PLATING : NICKEL 1μm min	5	POLYESTER			
1	PA	VIOLET	4	POLYSTYRENE			
NO.	MATERIAL	FINISH	REMARKS	NO.	MATERIAL	FINISH	REMARKS

UNITS mm		SCALE 2:1	COUNT 1	DESCRIPTION OF REVISIONS	DESIGNED	CHECKED	DATE
HRS HIROSE ELECTRIC CO., LTD.		APPROVED : AH. EDASHIGE	2023. 07. 10	DRAWING NO.	EDC-402828-00-00		
		CHECKED : TY. MOGI	2023. 07. 10	PART NO.	ZE05H-2P-2V (B)		
		DESIGNED : HR. EGAWA	2023. 07. 10	CODE NO.	CL0752-2325-0-00		
		DRAWN : AN. SAIKI	2023. 07. 10		1/2		

Jan.1.2025 Copyright 2025 HIROSE ELECTRIC CO., LTD. All Rights Reserved. In case of consideration for using Automotive equipment / device which demand high reliability, kindly contact our sales window correspondents.

Jan.1.2025 Copyright 2025 HIROSE ELECTRIC CO., LTD. All Rights Reserved.
 In case of consideration for using Automotive equipment / device which demand high reliability, kindly contact our sales window correspondents.

PACKING STYLE

PACKING STYLE DRAWING

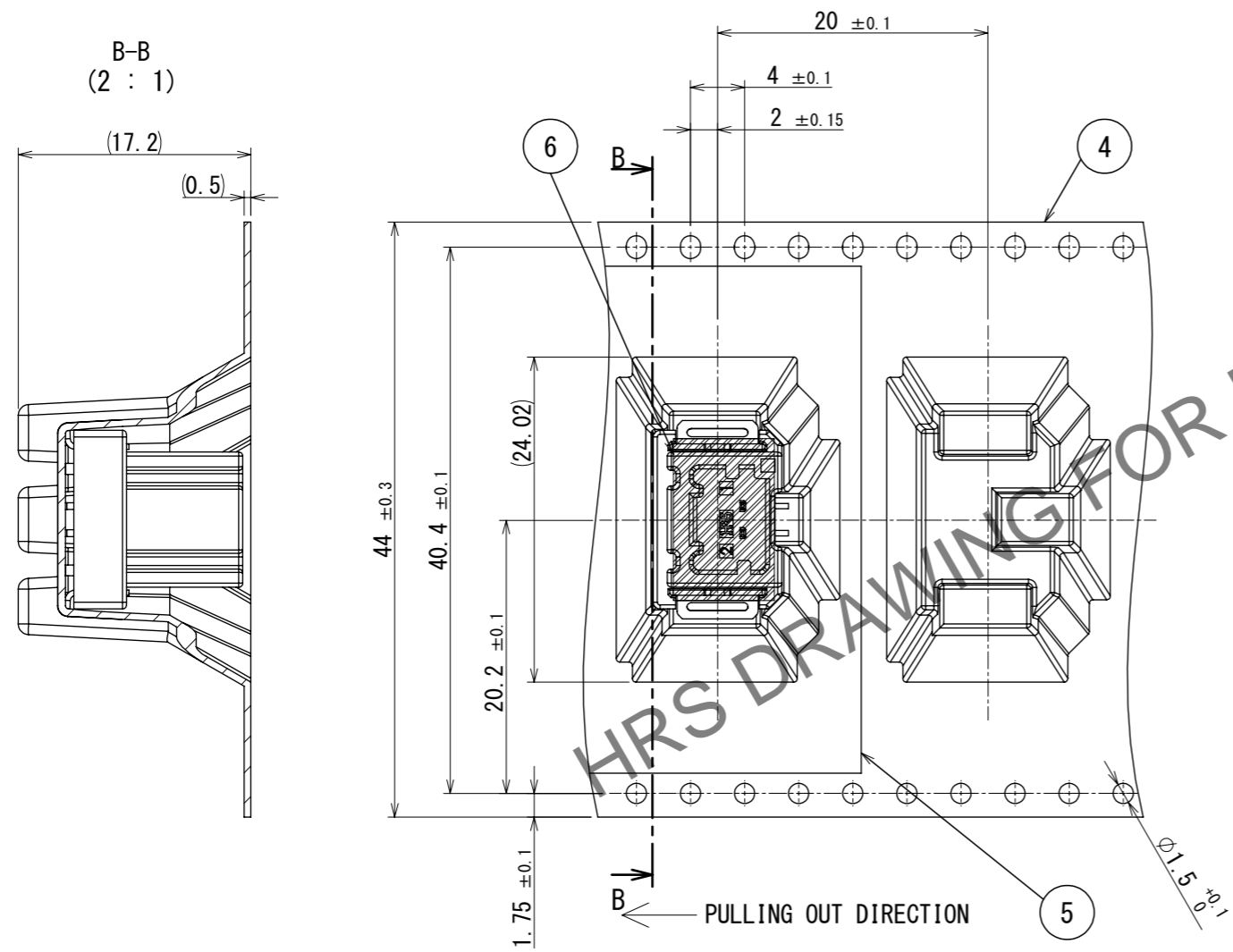

REEL DIMENSION (FREE)

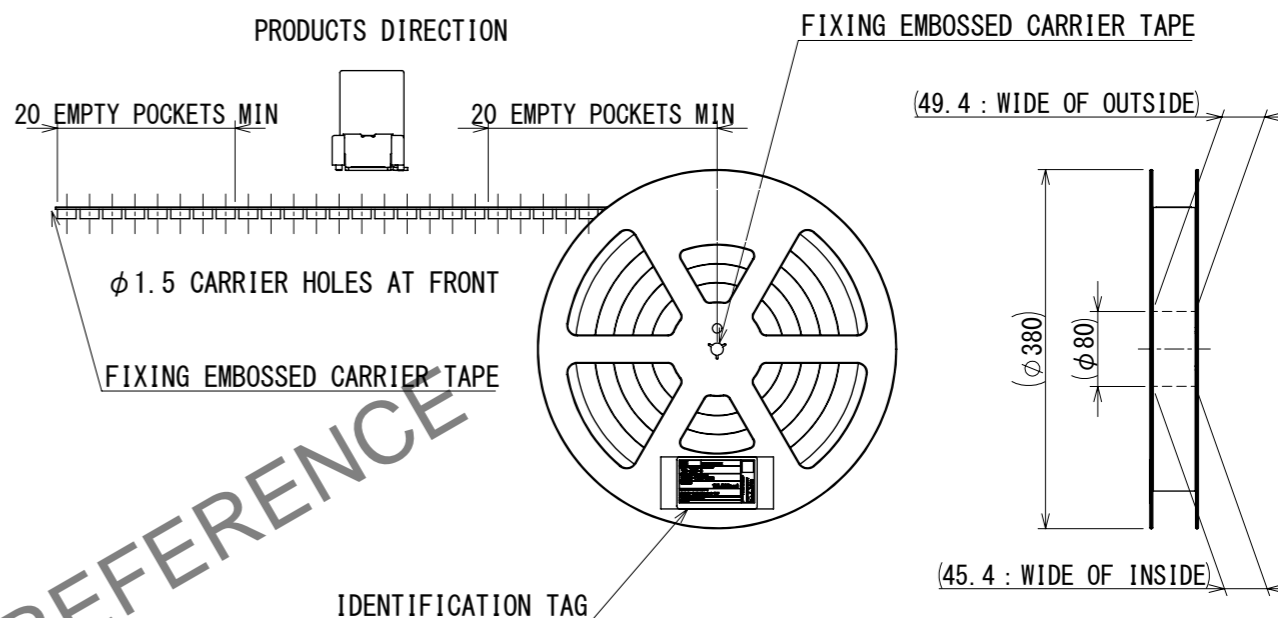

250 PCS/REEL

CARDBOARD DIMENSION (FREE)

W= (405) (mm)
 D= (405) (mm)
 H= (51) (mm)

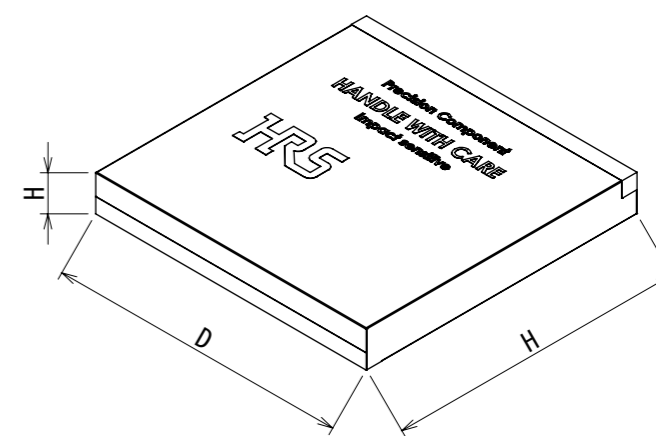

HRS	DRAWING NO.	EDC-402828-00-00	2/2
	PART NO.	ZE05H-2P-2V (B)	
	CODE NO.	CL0752-2325-0-00	