

May.1.2026 Copyright 2026 HIROSE ELECTRIC CO., LTD. All Rights Reserved.  
In case of consideration for using Automotive equipment / device which demand high reliability, kindly contact our sales window correspondents.

ELV, RoHS COMPLIANT

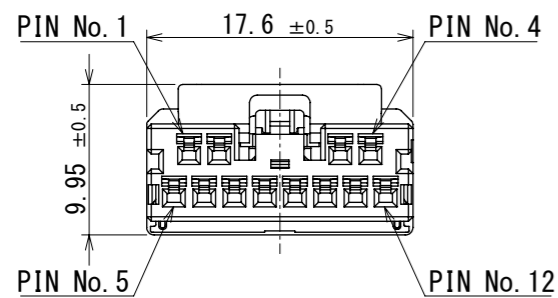

① RETAINER AND CPA PRESET

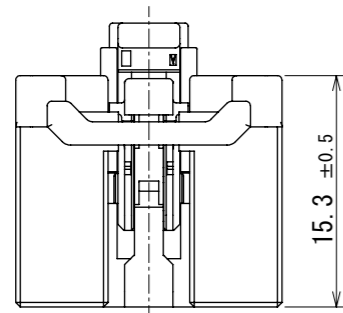
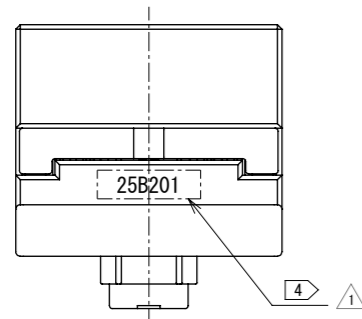
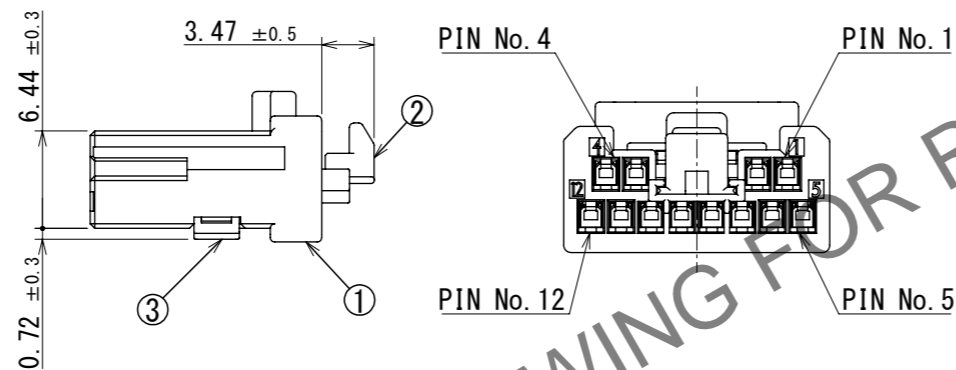

② RETAINER AND CPA SET

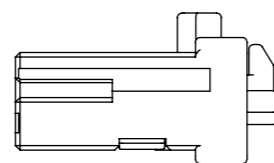

- NOTE. ① RETAINER AND CPA IS TEMPORARILY ASSEMBLED INTO HOUSING.  
 ② RETAINER TO BE COMPLETELY ASSEMBLED INTO POSITION AFTER CONTACT IS INSERTED.  
 CPA TO BE COMPLETELY ASSEMBLED INTO POSITION AFTER CONNECTOR IS MATED.  
 3. MINOR BLACK SPOTS THAT MAY OCCASIONALLY APPEAR ON THE RESIN SURFACE DO NOT IMPACT THE PRODUCT'S PERFORMANCE AND ARE CONSIDERED ACCEPTABLE FOR USE.  
 ④ THE LOT NUMBER IS SHOWN AT THE INDICATED LOCATION. THE CONTENT IS ACCORDING TO TAD-H0002.  
 FOR EXAMPLE: FEBRUARY 20, 2025, LINE 1 . . . 25B201.  
 ⑤ PLEASE REFER TO ETAD-T1113-00(ZE05C SERIES HANDLING INSTRUCTIONS) FOR DETAILS IN USE.

Packaging Specification

(1) After placing parts in trays, stack in six layers. (Top layer will be empty.)

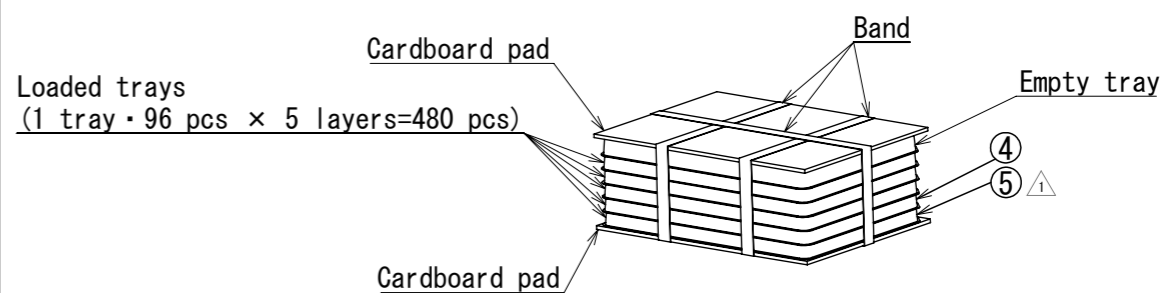

(2) Place bound trays in box, then place cardboard sheet on top.

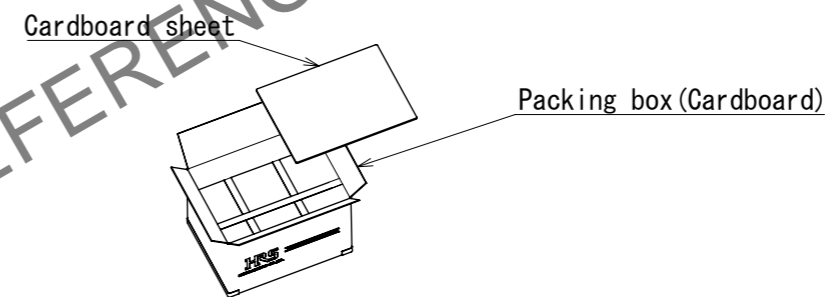

(3) Using packing tape, affix sheet of cardboard to box in four places. (4) Place lid on box and seal with packing tape.

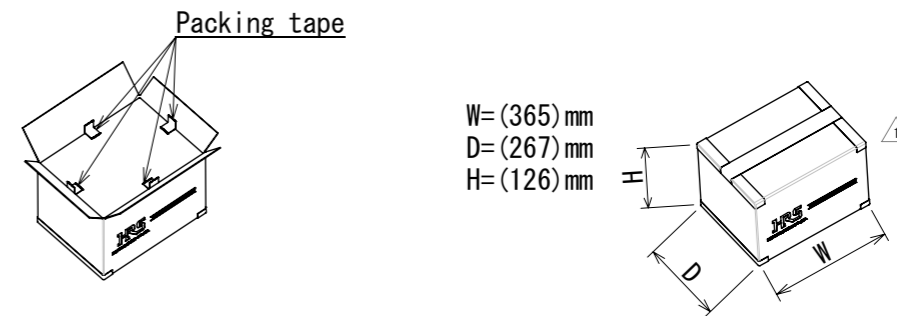

3	PA	BEIGE		5	POLYSTYRENE			
2	PBT	WHITE		4	POLYSTYRENE			
1	PA	BLACK						
NO.	MATERIAL	FINISH	REMARKS	NO.	MATERIAL	FINISH	REMARKS	
UNITS		SCALE	COUNT	DESCRIPTION OF REVISIONS		DESIGNED	CHECKED	DATE
mm		2:1	⑤ 6	DIS-T-00025933		YILAI WU	MH. SHOUJI	2025. 12. 09
<b>HRS</b> HIROSE ELECTRIC CO., LTD.		APPROVED : AH. EDASHIGE	2025. 10. 14	DRAWING NO.		EDC-403509-00-00		
		CHECKED : MH. SHOUJI	2025. 10. 14	PART NO.		ZE05C-12DS-HU/R/C		
		DESIGNED : YILAI WU	2025. 10. 10	CODE NO.		CL0752-2500-0-00		
		DRAWN : YILAI WU	2025. 10. 10					