

Jun. 1. 2026 Copyright 2026 HIROSE ELECTRIC CO., LTD. All Rights Reserved.
 use of consideration for using Automotive equipment / device which demand high reliability, kindly contact our sales window correspond

ELV, RoHS COMPLIANT

PACKAGING SPECIFICATION

- (1) 350pcs parts are contained in a plastic bag.
- (2) 4 plastic bags are contained in a carton.
(Total 1400 pcs in one carton)
- (3) Close the box and seal with packing tape.

W= (345) mm
 D= (240) mm
 H= (135) mm

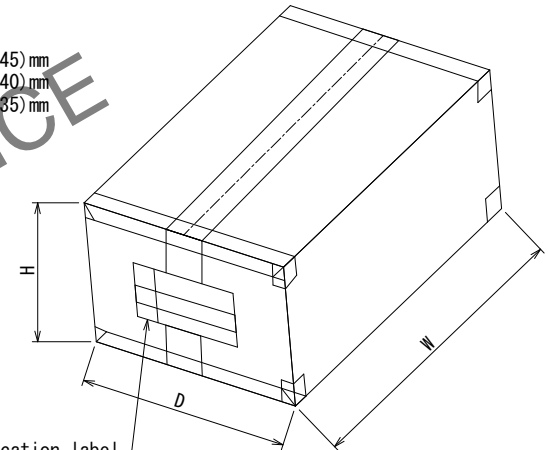

Identification label

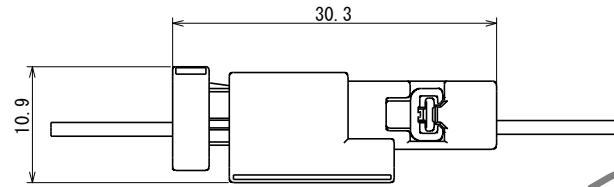
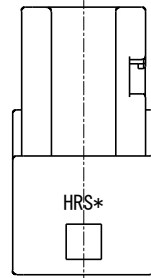

Mated connectors

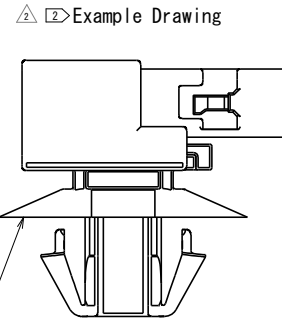
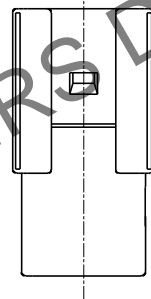
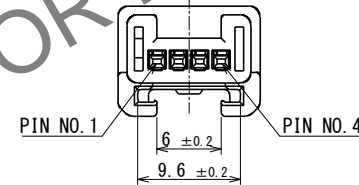
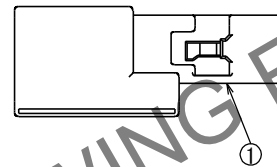
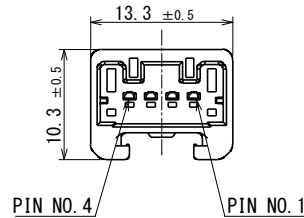
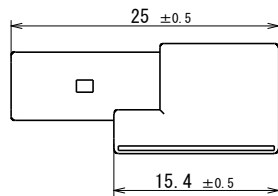

Example Drawing

CLIP

NOTE) 1. RETAINER ZE05-4P-R (CL752-2701-0-00) SHOULD BE USED
 2. CLIP OPTIONS ARE AVAILABLE.
 THE RECOMMENDED CLIP IS HELLERMANNTYTON'S CC26SFT712 (WWW.HELLERMANNTYTON.COM).
 FOR DETAILS, PLEASE CONTACT THE CLIP MANUFACTURER.

NO.	MATERIAL	FINISH	REMARKS	NO.	MATERIAL	FINISH	REMARKS		
1	PA	BLACK							
TOLERANCES SEE TABLE FOR SPECIFIED, UNLESS OTHERWISE		UNITS	SCALE	COUNT	DESCRIPTION OF REVISIONS	DESIGNED	CHECKED	DATE	
OVER TO TOLERANCES		mm	2:1	2	DIS-T-00026144	ZHIGANG REN	TY. ISHIGURO	2025. 12. 25	
6	±0.3	ANGULAR	±1°	APPROVED	MH. SHOUJI	20250318	DRAWING No. EDC-409044-00-00		
6	18	±0.5		CHECKED	MH. SHOUJI	20250318	PART No. ZE05-4PP-HU		
18	50	±0.7		DESIGNED	CHUANXING YANG	20250318	CODE No. CL0752-2700-0-00		
50	125	±1		DRAWN	GANGGANG YU	20250318			
ASSEMBLY DRAWING									