

Apr.1.2026 Copyright 2026 HIROSE ELECTRIC CO., LTD. All Rights Reserved.
In case of consideration for using Automotive equipment / device which demand high reliability, kindly contact our sales window correspondents.

ELV, RoHS COMPLIANT

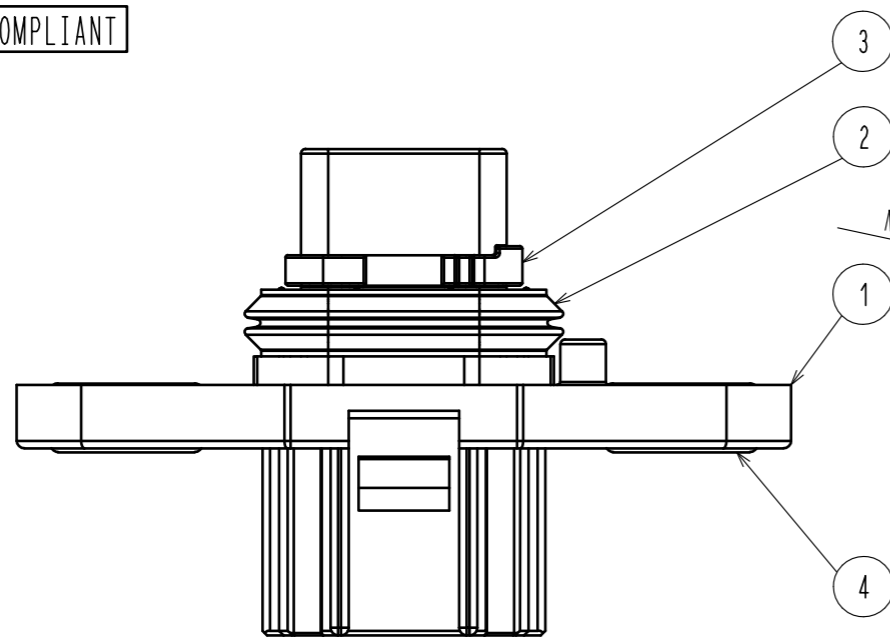

MOUNTING INTERFACE SPECIFICATION (2:1)

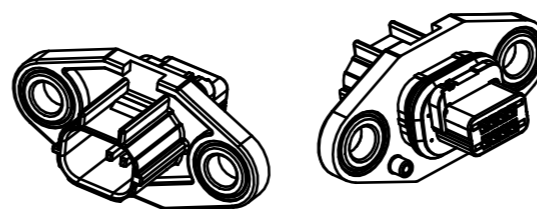
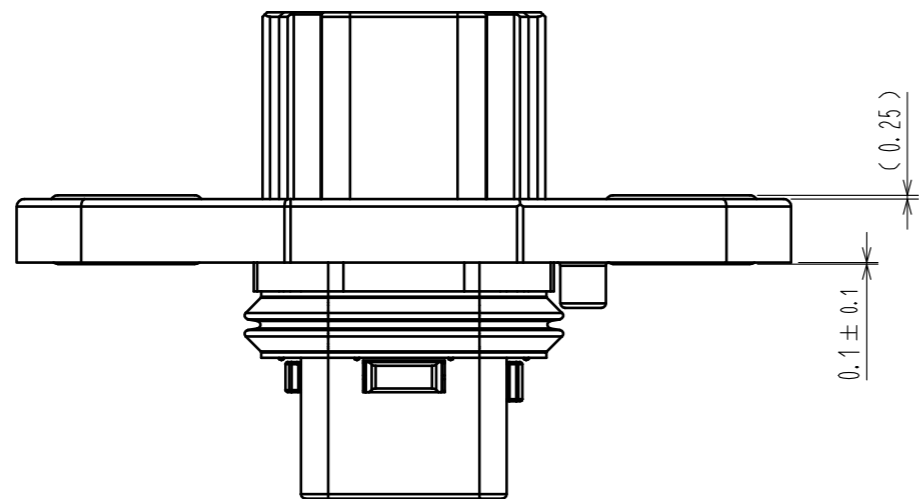
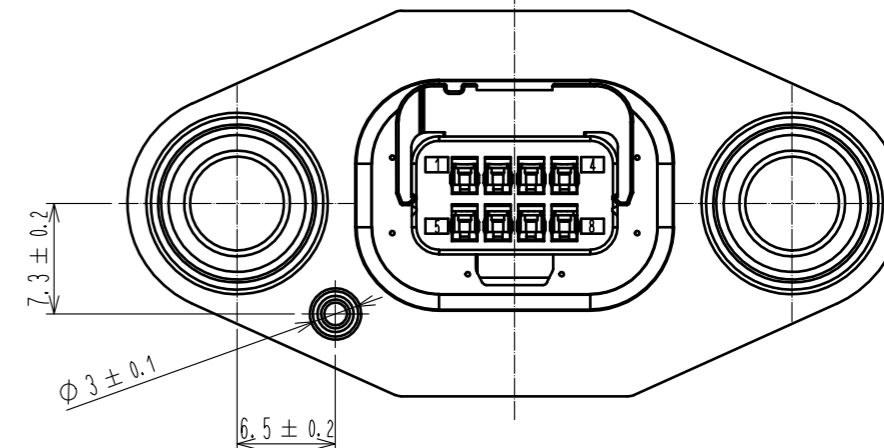
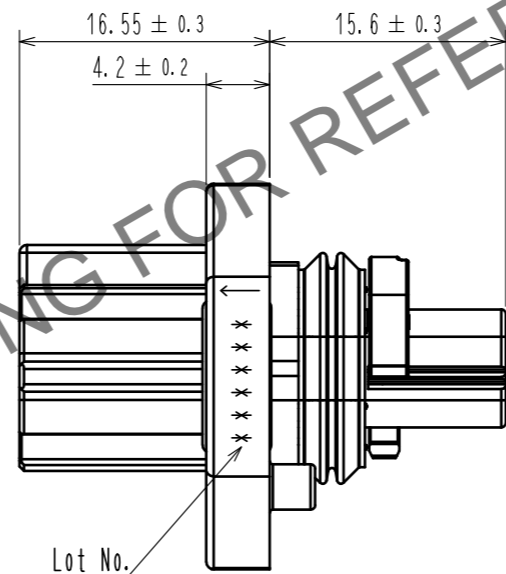
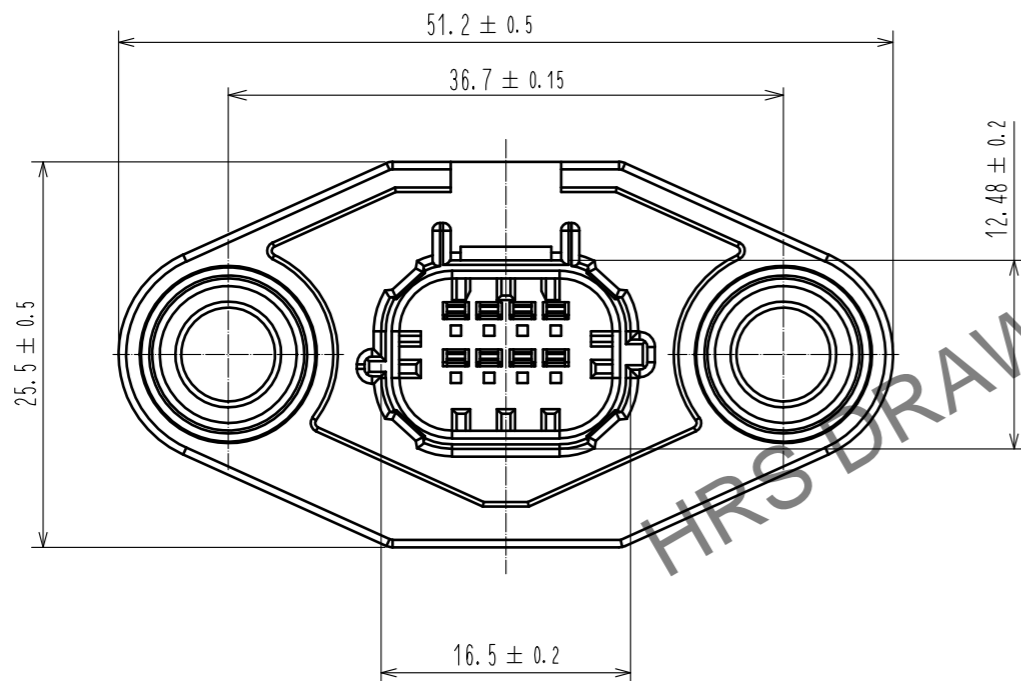
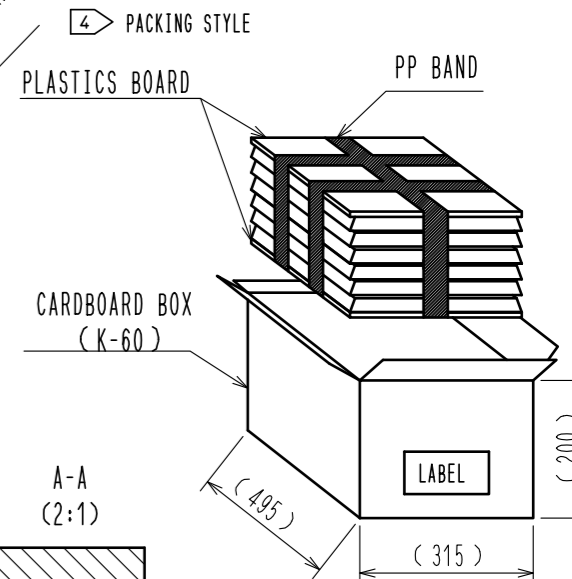
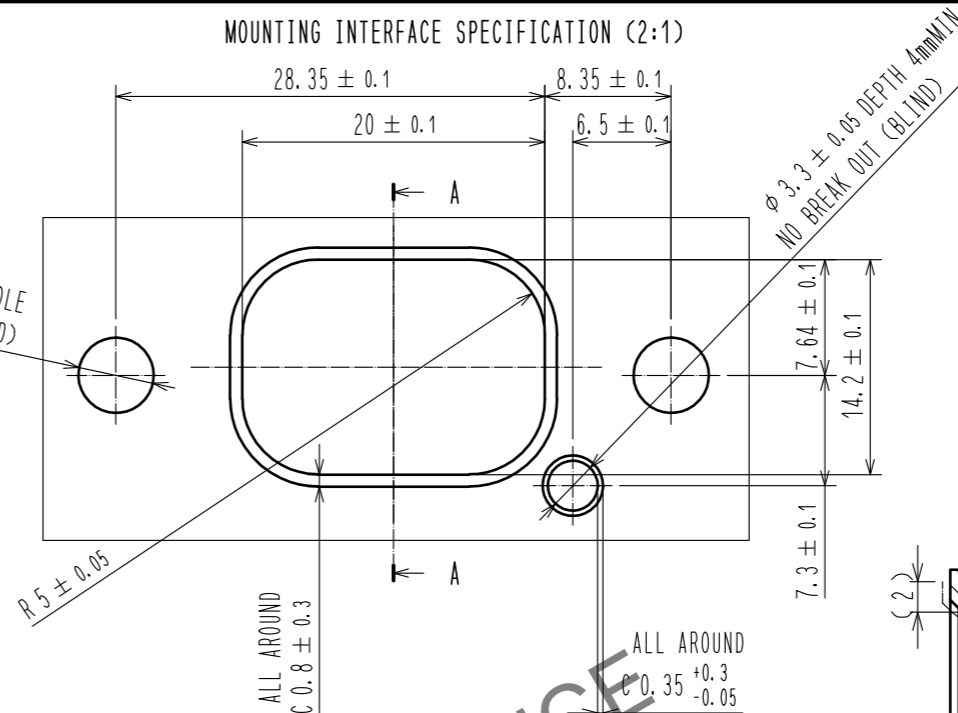

- ⚠ NOTE1. CONNECTOR CAN BE FIXED WITH M5 SCREWS ON THE PANEL.
(TIGHTENING TORQUE : MAX 5.5N · m)
- 2. APPLICABLE MATING CONNECTOR : ZE064W-8DS-HU/R(CB)
- 3. APPLICABLE PARTS : ZE064-2022PCF(CRIMP CONTACT)
- ⚠ 4. MAXIMUM QUANTITY OF PRODUCTS PER BOX:70 PCS PER TRAY × 5 LAYERS = 350 PCS.
AN EMPTY TRAY IS PUT ON THE TOP.
- 5. PLEASE REFER TO INSTRUCTION SHEET ETAD-T0670-00 BEFORE USE.

2	SILICONE	RED. OIL BLEEDING	4	SWCH	NICKEL PLATING 5 μm MIN.
1	PA	GRAY. UL94V-0	3	PA	BEIGE. UL94V-0
NO.	MATERIAL	FINISH . REMARKS	NO.	MATERIAL	FINISH . REMARKS
UNITS mm		SCALE 2 : 1	COUNT 3	DESCRIPTION OF REVISIONS DIS-T-00013369	DESIGNED TY. MOGI
HRS HIROSE ELECTRIC CO., LTD.		APPROVED : HK. UMEHARA	20190216	DRAWING NO. EDC-381036-00-00	CHECKED HK. UMEHARA
		CHECKED : HK. UMEHARA	20190216	PART NO. ZE064W-8DP-HU/R(CB)	DATE 20220317
		DESIGNED : HH. TSUKUMO	20190216	CODE NO. CL0753-2014-0-00	
		DRAWN : DS. HIROWATARI	20190216		

Apr.1.2026 Copyright 2026 HIROSE ELECTRIC CO., LTD. All Rights Reserved.
In case of consideration for using Automotive equipment / device which demand high reliability, kindly contact our sales window correspondents.

⚠ PRECAUTIONS

THIS CONNECTOR HAS A STRUCTURE IN WHICH THE PANEL SEAL, WHICH IS A PART FOR MAINTAINING THE WATERPROOFNESS, IS EXPOSED OUTSIDE. IF NOT USED CORRECTLY, THE PANEL SEAL MAY NOT FUNCTION PROPERLY AND THE WATERPROOF PROPERTY MAY BE IMPAIRED. SO THE INSTRUCTION SHEET ETAD-T0670-00 NEED TO BE FOLLOWED.

THE FOLLOWING IS AN EXCERPT OF NOTES REGARDING PANEL SEAL.

- Please hold connectors except panel seal part.
And also be careful that the oil of the panel seal not to be touched with other objects except connector housing and retainer.

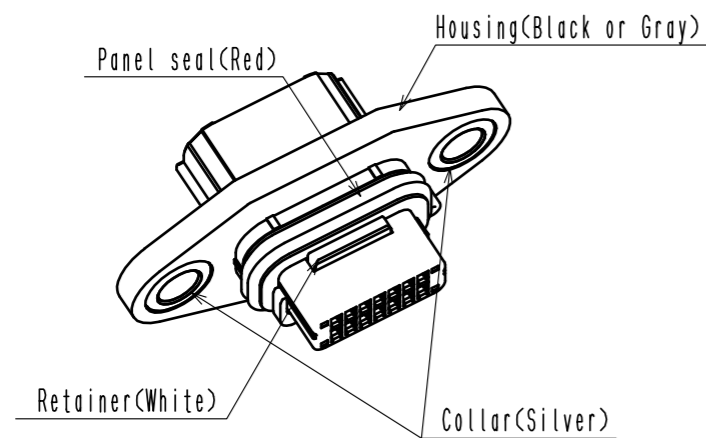

- Please protect the panel seal not to be touched with other objects after insert the terminals and set the retainer. The protector is required not to be deformed excessively during packaging, shipping and being stored.

e. x.) Cover the hole part of connector with plastic cup and tighten the cables to hold.

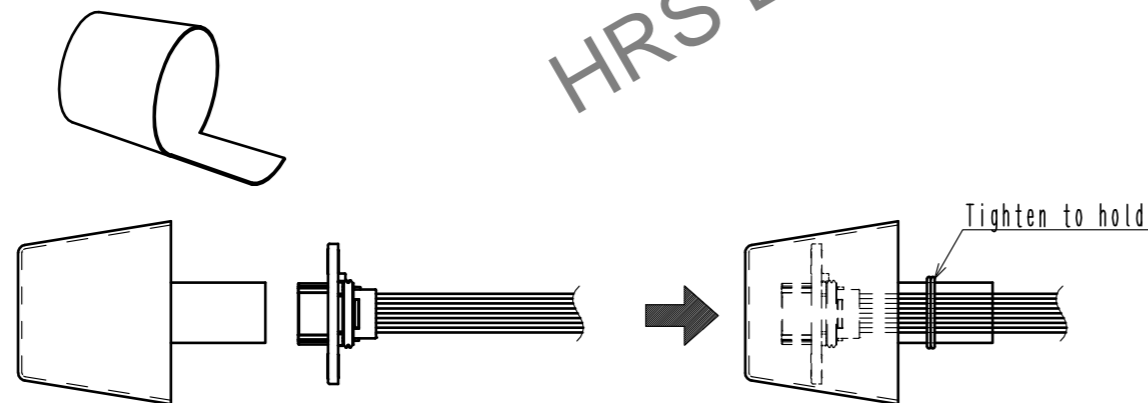

- Lightly press the panel seal against the chamfer of the panel frontage to position the connector.

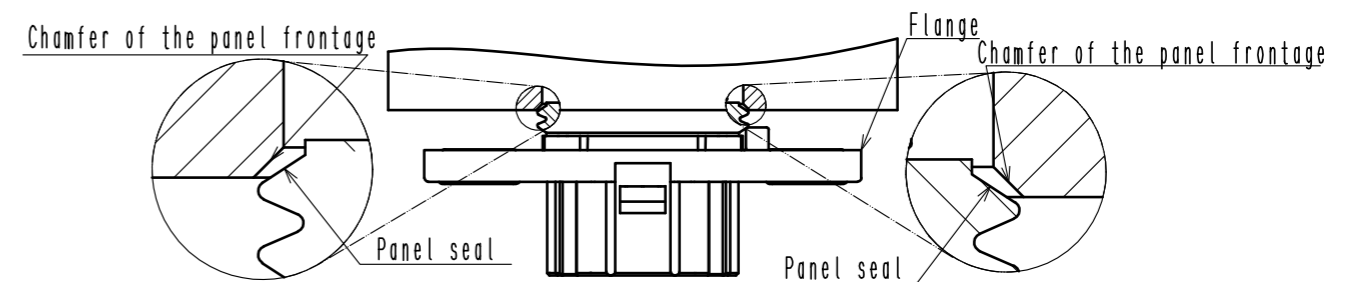

While in this position, press on the male connector housing or collar and push the male connector straight into the enclosure opening. Push straight in until the male connector flange touches the panel.

- ※ Pushing the male connector diagonally or pulling the harness side into the enclosure opening may cause excessive load on the male connector, which may result in damage.

OK :

Press both sides of the collar evenly

NG① : Press the collar unevenly.

NG② : Pull on the end of the harness.

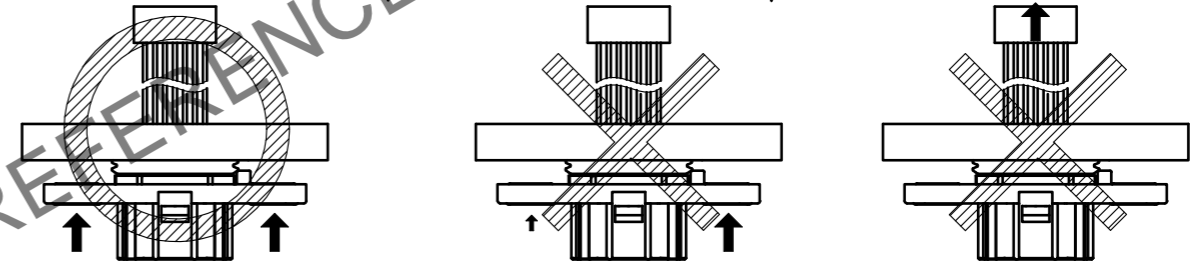

- Make sure that the connector does not rise excessively above the surface of the panel when you take your hand off the connector. If it floats up excessively, something may have gone wrong. In that case, pull the connector out of the panel and start the process all over again.

Approximate amount of lift :

2 mm or less, or no panel seal is visible through the gap.

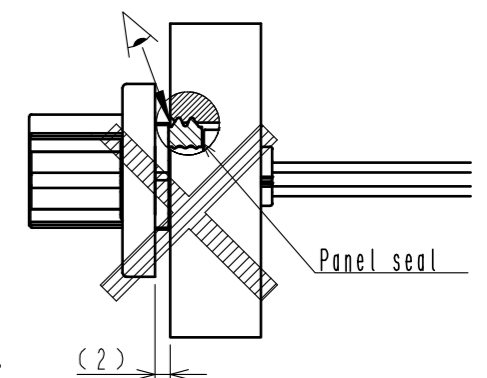

- ※ Do not reattach the connector to the panel more than once, and only do so consecutively to the same panel. Before reattaching the harness, check the appearance of the panel seal, and if it is damaged or deformed, use a new harness. Also, reattaching the connector more than once or reattaching it to a different panel may cause excessive load on the panel seal, so please use a new harness in such cases.

HRS

DRAWING NO.	EDC-381036-00-00
PART NO.	ZE064W-8DP-HU/R(CB)
CODE NO.	CL0753-2014-0-00

⚠ 2/2