

Apr.1.2026 Copyright 2026 HIROSE ELECTRIC CO., LTD. All Rights Reserved.  
In case of consideration for using Automotive equipment / device which demand high reliability, kindly contact our sales window correspondents.

ELV, RoHS COMPLIANT

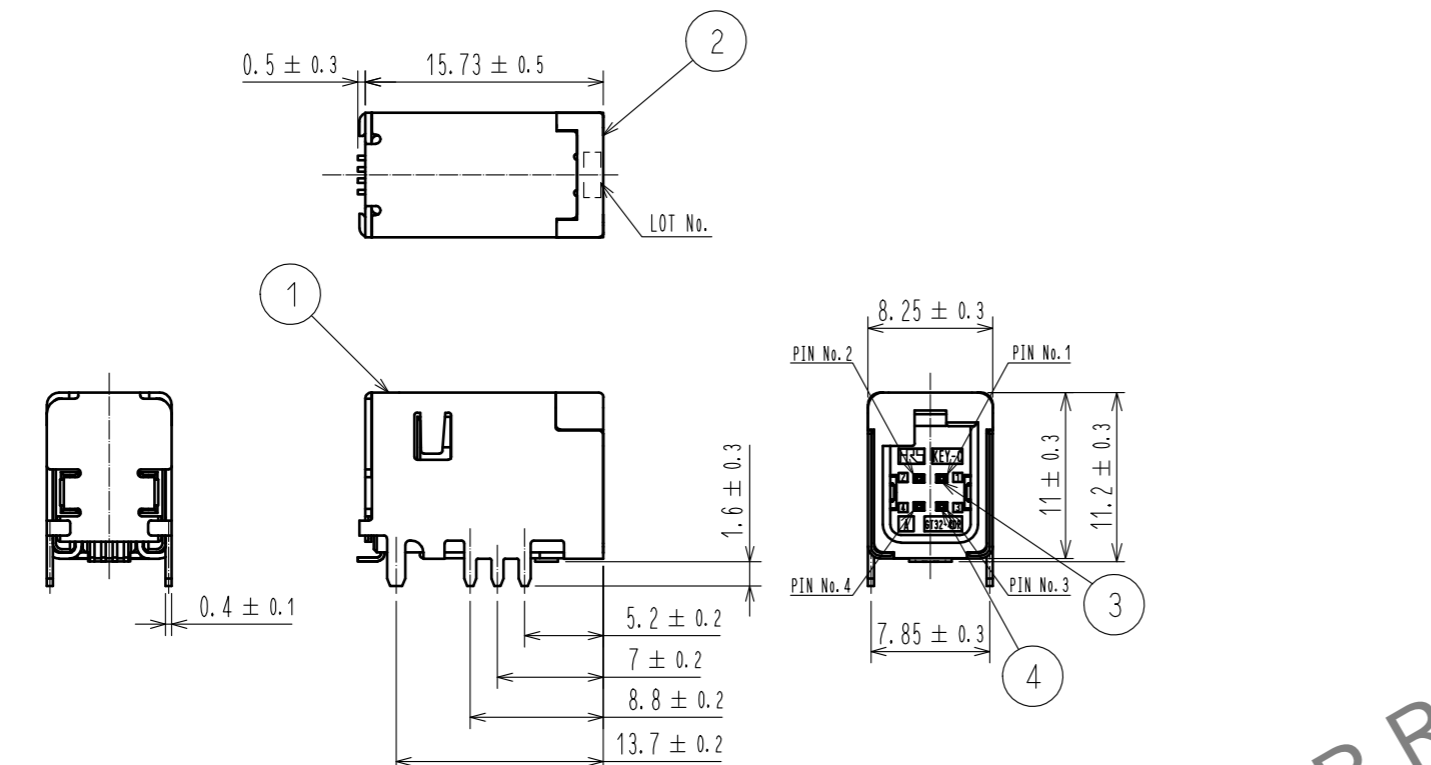

MATED CONNECTORS

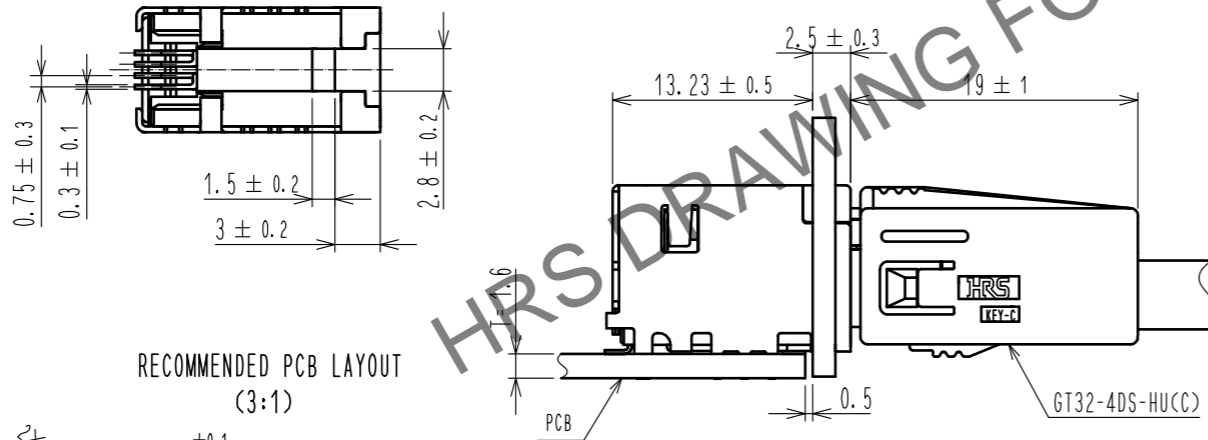

RECOMMENDED PCB LAYOUT (3:1)

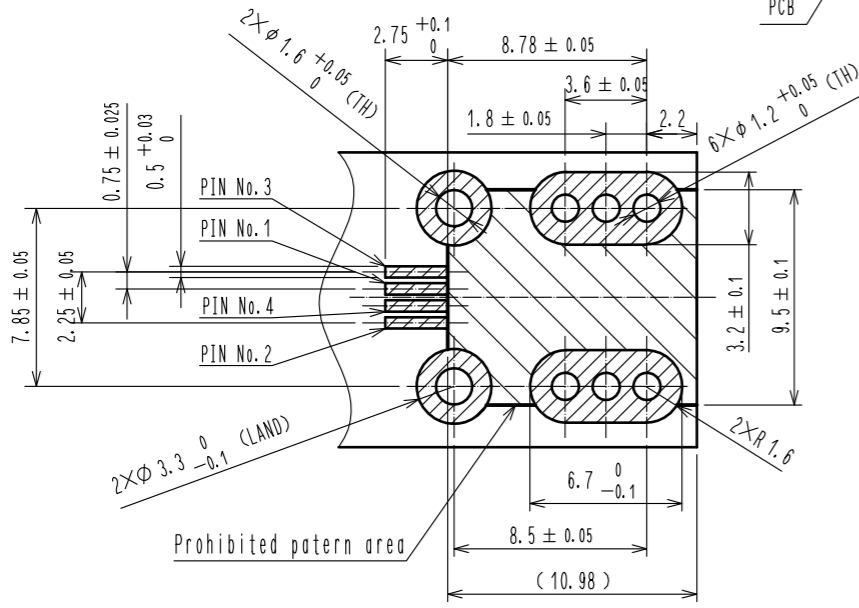

RECOMMENDED PANEL CUTOUT

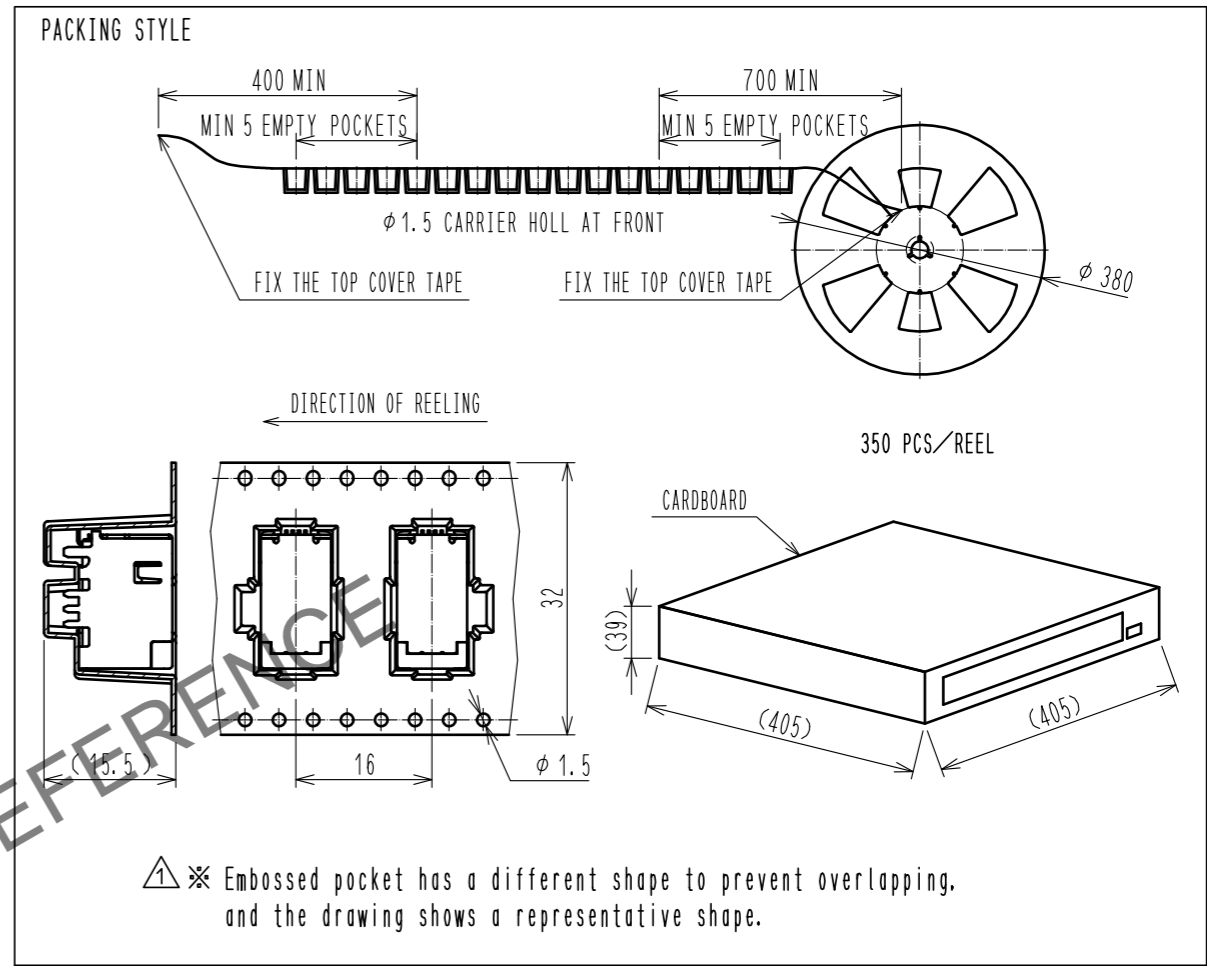
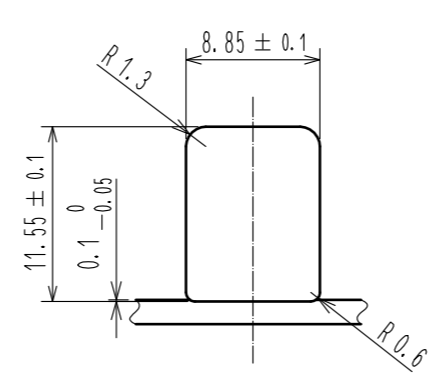

NOTES

- RECOMMENDED REFLOW PROFILE (SEE RIGHT GRAPH)  
CYCLE TIME: UP TO 2 CYCLES OF REFLOW SOLDERING ARE POSSIBLE UNDER THE CONDITIONS. PROVIDED THAT THERE IS A RETURN TO NOMAL TEMPERATURE BETWEEN THE FIRST AND SECOND CYCLE.  
PEAK TEMPERATURE: 250°C  
230°C MIN. FOR 20 TO 40 SECONDS.  
PREHEATING AREA 150~180°C FOR 60 TO 120 SECONDS.
- HAND SOLDERING: 280~300°C, 2SECONDS MAX.
- CONTACT COPLANARITY: 0.1mm MAX.
- RECOMMENDED THICKNESS OF PCB: 1.6mm
- RECOMMENDED THICKNESS OF SOLDERING PASTE: 0.12mm

TEMP. (°C)

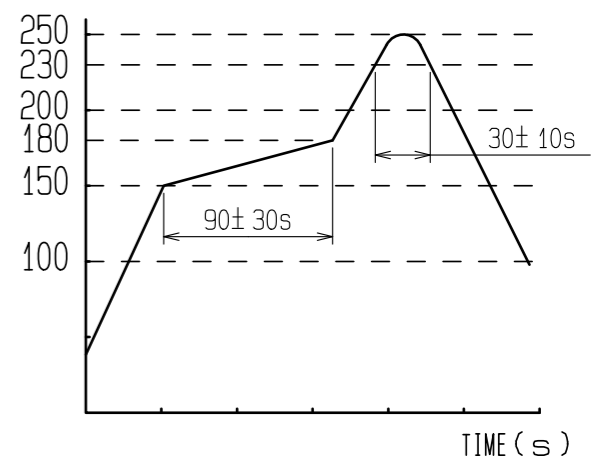

2	PA	BLUE	4	BRASS	TIN PLATING		
1	COPPER ALLOY	TIN PLATING	3	BRASS	TIN PLATING		
NO.	MATERIAL	FINISH . REMARKS	NO.	MATERIAL	FINISH . REMARKS		
UNITS mm		SCALE 2 : 1	COUNT 1	DESCRIPTION OF REVISIONS DIS-T-00018049	DESIGNED TS. KUBOTA	CHECKED KT. MAKI	DATE 20230512
<b>HRS</b> HIROSE ELECTRIC CO., LTD.		APPROVED : AR. SHIRAI	20190111	DRAWING NO. EDC-361829-12-01		PART NO. GT32-4DP-1.5H(C)(12)	
		CHECKED : TH. MIZUGUCHI	20190110	CODE NO. CL0782-0063-9-12		1/1	
		DESIGNED : TS. KUBOTA	20190110				
		DRAWN : TS. KUBOTA	20190110				