

Apr.1.2025 Copyright 2025 HIROSE ELECTRIC CO., LTD. All Rights Reserved.
 In case of consideration for using Automotive equipment / device which demand high reliability, kindly contact our sales window correspondents.

RoHS, ELV COMPLIANT

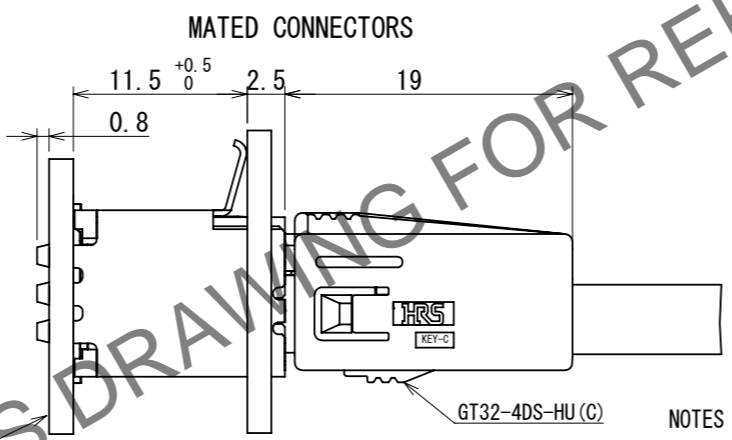

RECOMMENDED PCB LAYOUT (4:1)

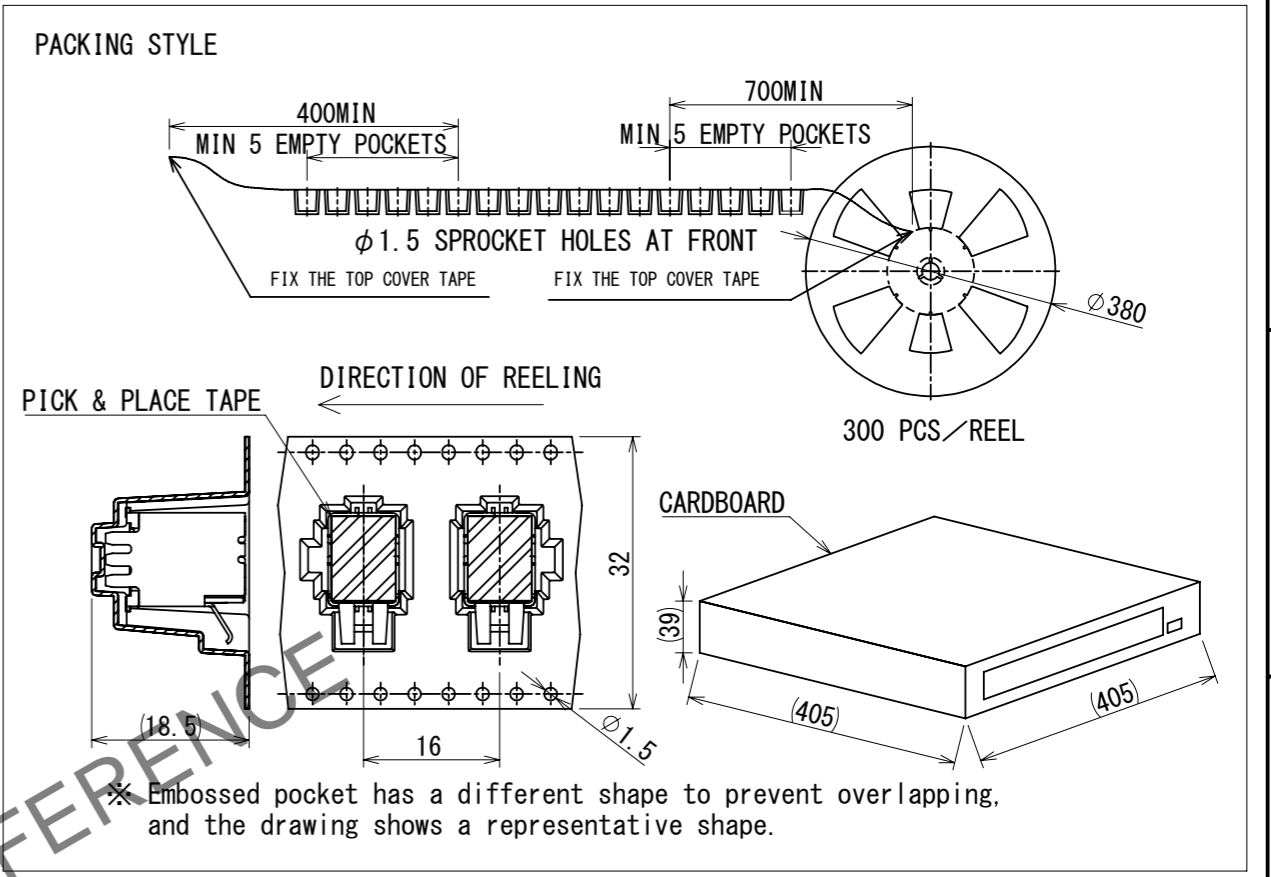
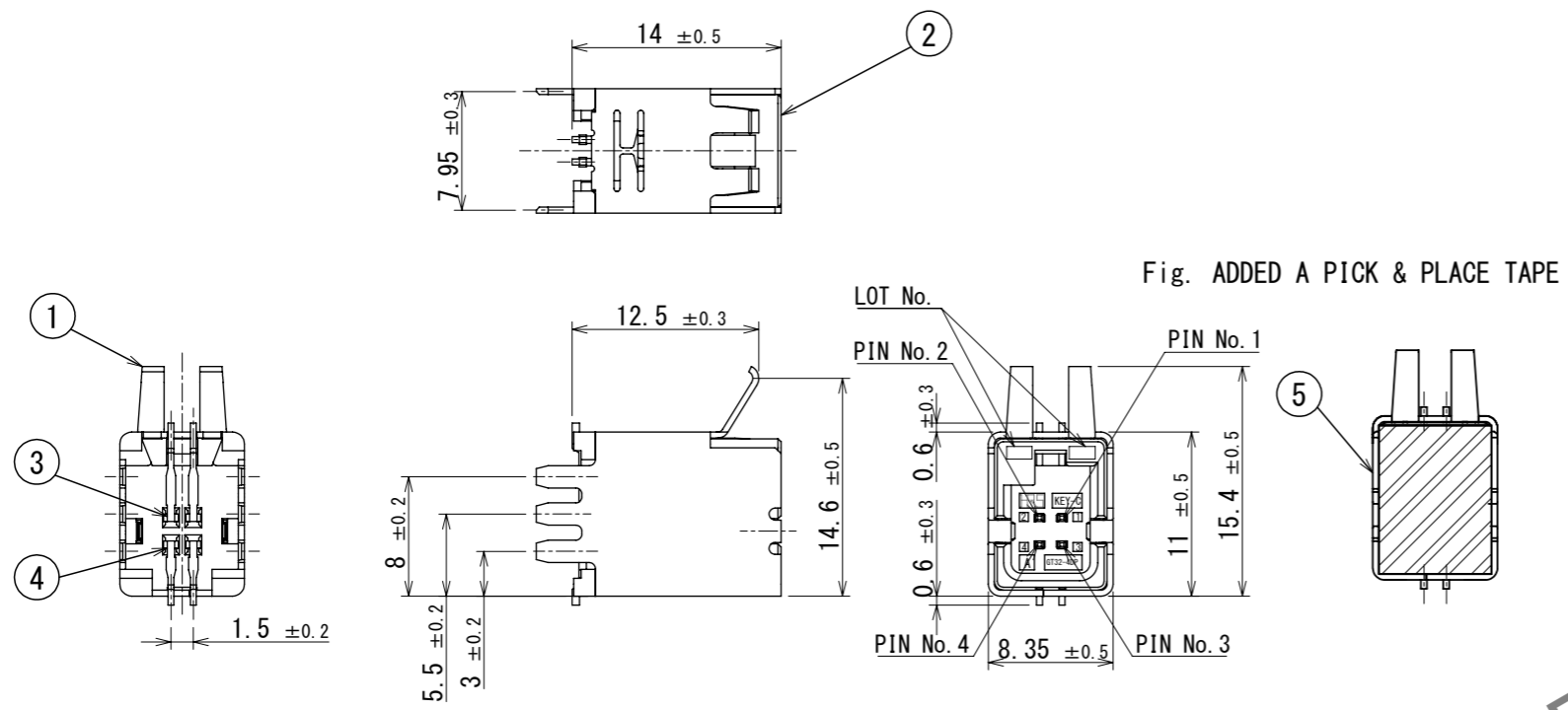
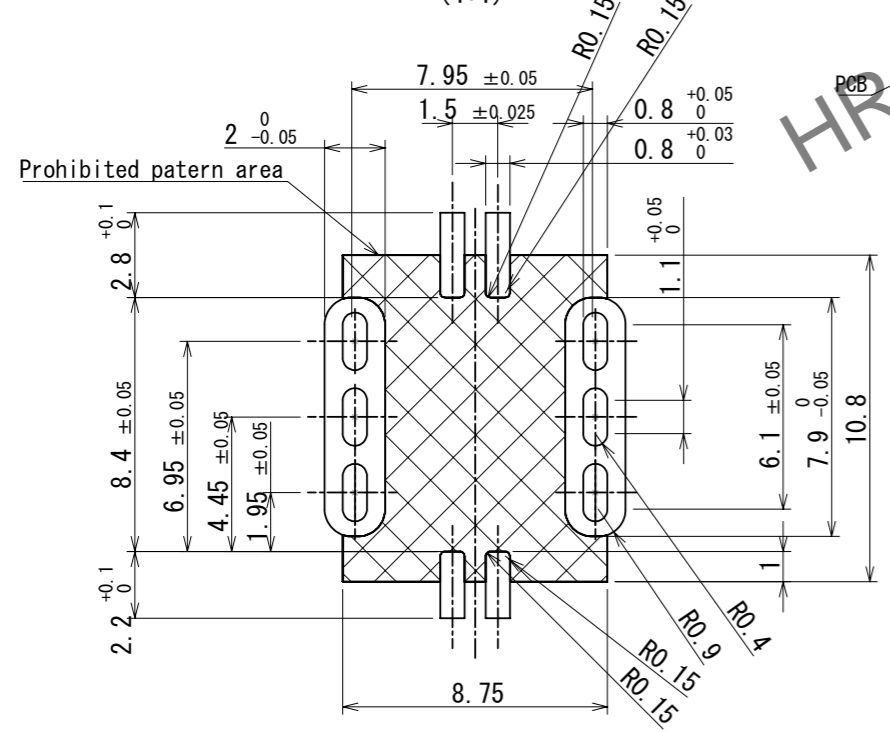

RECOMMENDED PANEL CUTOUT

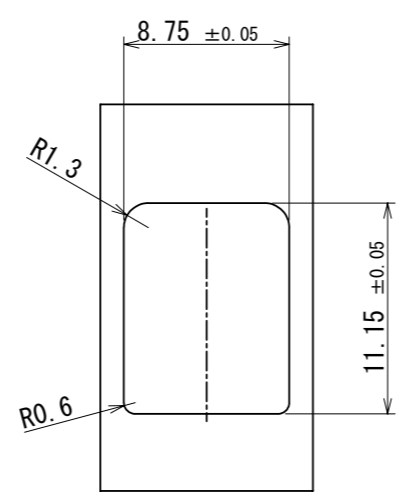

NOTES

- RECOMMENDED REFLOW PROFILE (SEE RIGHT GRAPH)
 CYCLE TIME: UP TO 2 CYCLES OF REFLOW SOLDERING ARE POSSIBLE UNDER THE CONDITIONS, PROVIDED THAT THERE IS A RETURN TO NORMAL TEMPERATURE BETWEEN THE FIRST AND SECOND CYCLE.
 PEAK TEMPERATURE: 250°C
 230°C MIN, FOR 20 TO 40 SECONDS.
 PREHEATING AREA 150~180°C FOR 60 TO 120 SECONDS.
- HAND SOLDERING: 280~300°C, 2SECONDS MAX.
- CONTACT COPLANARITY: 0.1mm MAX.
- RECOMMENDED THICKNESS OF PCB: 1.6mm
- RECOMMENDED THICKNESS OF SOLDERING PASTE: 0.12mm

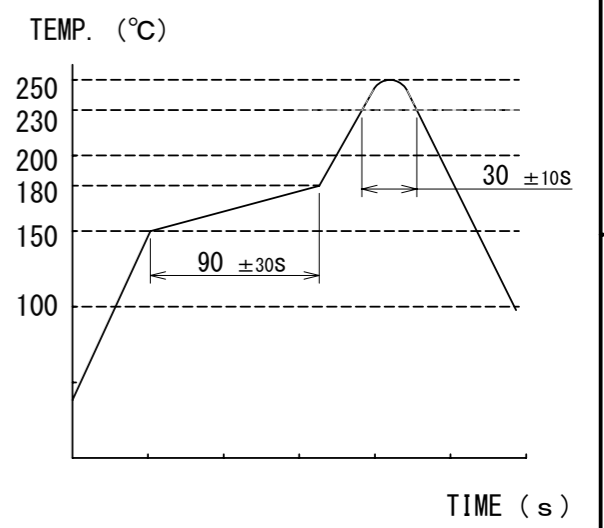

3	BRASS	TIN PLATING	5	POLYIMIDE	PICK & PLACE TAPE		
2	PA	BLUE	4	BRASS	TIN PLATING		
1	COPPER ALLOY	TIN PLATING					
NO.	MATERIAL	FINISH	REMARKS	NO.	MATERIAL	FINISH	REMARKS

UNITS	mm	SCALE	2:1	COUNT	0	DESCRIPTION OF REVISIONS		DESIGNED	CHECKED	DATE
DIS-T-00018485						KN. YANAGIMOTO	EJ. WAKATSUKI	2023. 10. 19		
APPROVED : AR. SHIRAI		2018. 09. 07		DRAWING NO.		EDC-362125-30-01				
CHECKED : TH. MIZUGUCHI		2018. 09. 06		PART NO.		GT32-4DP-1.5V (C) (30)				
DESIGNED : TS. KUBOTA		2018. 09. 05		CODE NO.		CL0782-0067-0-30				
DRAWN : TS. KUBOTA		2018. 09. 05								