

Jan.1.2025 Copyright 2025 HIROSE ELECTRIC CO., LTD. All Rights Reserved.
 In case of consideration for using Automotive equipment / device which demand high reliability, kindly contact our sales window correspondents.

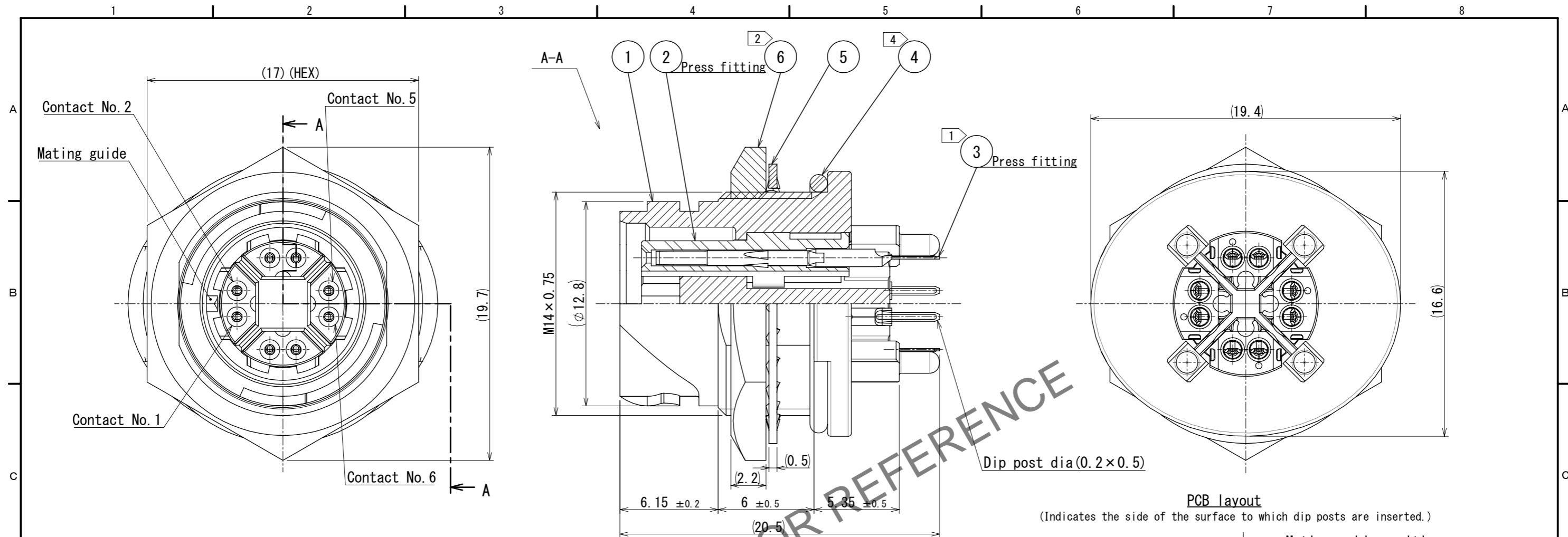

10/100 Mbit/s, 1/10 Gbit/s
 Ethernet contacts arrangement

| Contact No. | Signal | |
|-------------|---------------|-------------|
| | 10/100 Mbit/s | 1/10 Gbit/s |
| 1 | TX+ | BI_DA+ |
| 2 | TX- | BI_DA- |
| 3 | N.C | BI_DC+ |
| 4 | N.C | BI_DC- |
| 5 | RX+ | BI_DB+ |
| 6 | RX- | BI_DB- |
| 7 | N.C | BI_DD+ |
| 8 | N.C | BI_DD- |

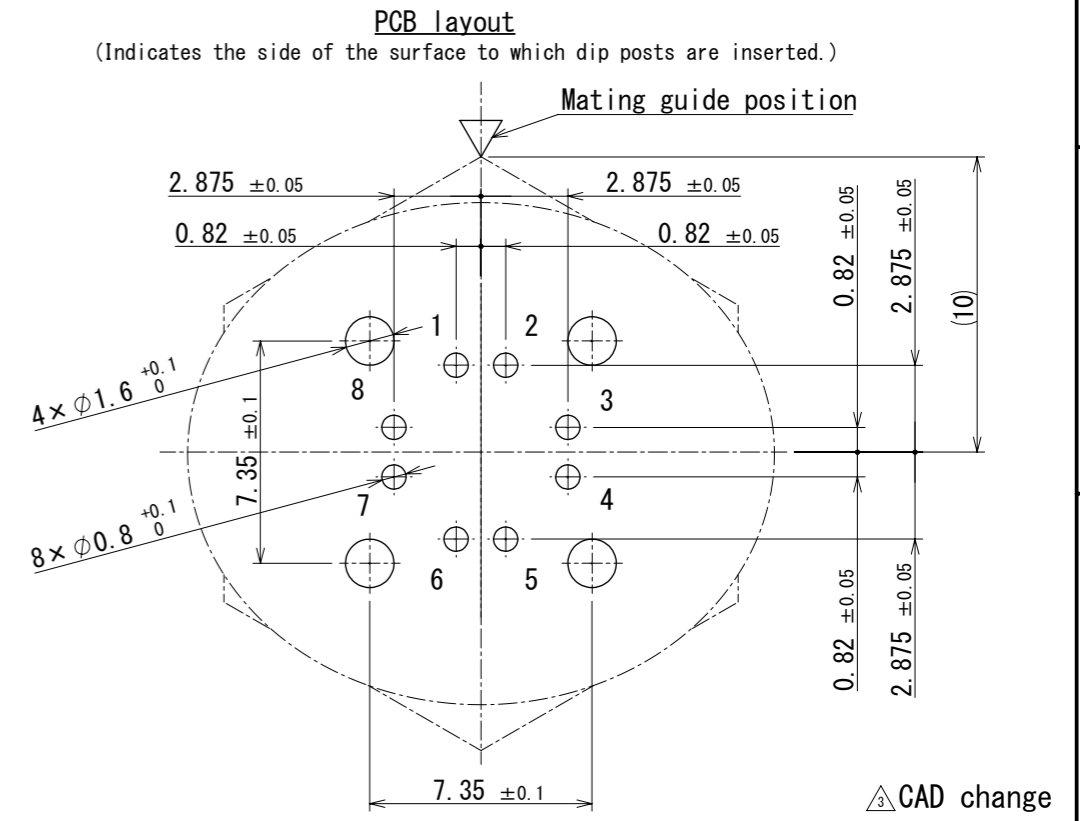
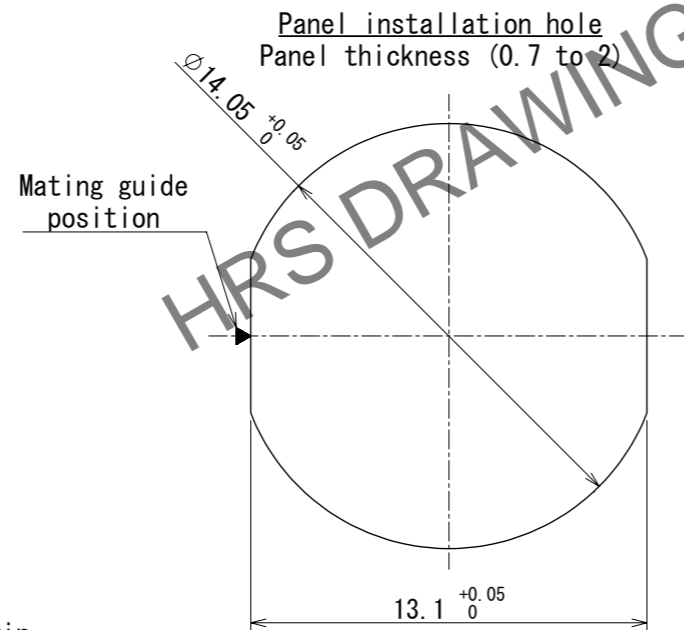

- Notes
- ① Plating (Ref. No. ③)
 Contact area : Gold 0.2 μm min.
 Dip area : Gold 0.03 μm min.
 Under plating : Nickel 2 μm min.
 - ② The recommended threaded torque of ref.No. ⑥ to be 2 to 2.5 N·m.
 Apply thread locker to the threaded position of ref.No. ① in order to prevent ref.No. ⑥ from loosening.
 Apply thread locker : Loctite 263, Henkel japan LTD.
 - ③ Rotation example of ref.No. ③ are shown.
 - ④ When installing this product in a housing, make sure that ref No. ④ is securely installed in the groove of part number (1) as shown in the illustration.
 If ref No. ④ is detached or engaged, the waterproof property will not be maintained.
 - ⑤ This product must be soldered in accordance with the harnessing instructions ETAD-C0480-00.
 - ⑥ Refer to Packing Specification ETAP-C0452-00 for the packaging of this product.

| 3 | Phosphor bronze | ① | 6 | Brass | Nickel plating | | |
|------------------------|-------------------------------|-----------------------|---------|-----------------------------|----------------|---|---------|
| 2 | Polyphenylene sulfide (Black) | | 5 | Phosphor bronze | Nickel plating | | |
| 1 | Zinc alloy | Nickel plating | 4 | Silicone rubber | (Red) | | |
| NO. | MATERIAL | FINISH | REMARKS | NO. | MATERIAL | FINISH | REMARKS |
| UNITS mm | | SCALE 4:1 | | COUNT ③ 1 | | DESCRIPTION OF REVISIONS DIS-C-00018897 | |
| DESIGNED Y.J. KOGA | | CHECKED HY. KOBAYASHI | | DATE 2024. 12. 13 | | DRAWING NO. EDC-391834-40-00 | |
| APPROVED : TP. KOMATSU | | 2023. 01. 20 | | PART NO. LF10WBRBH-8SD (40) | | CODE NO. CL0136-0058-0-40 | |
| CHECKED : KI. NAGANUMA | | 2023. 01. 20 | | | | | |
| DESIGNED : KN. IKEHARA | | 2023. 01. 20 | | | | | |
| DRAWN : KN. IKEHARA | | 2023. 01. 20 | | | | | |