

Nov.1.2024 Copyright 2024 HIROSE ELECTRIC CO., LTD. All Rights Reserved.
In case of consideration for using Automotive equipment / device which demand high reliability, kindly contact our sales window correspondents.

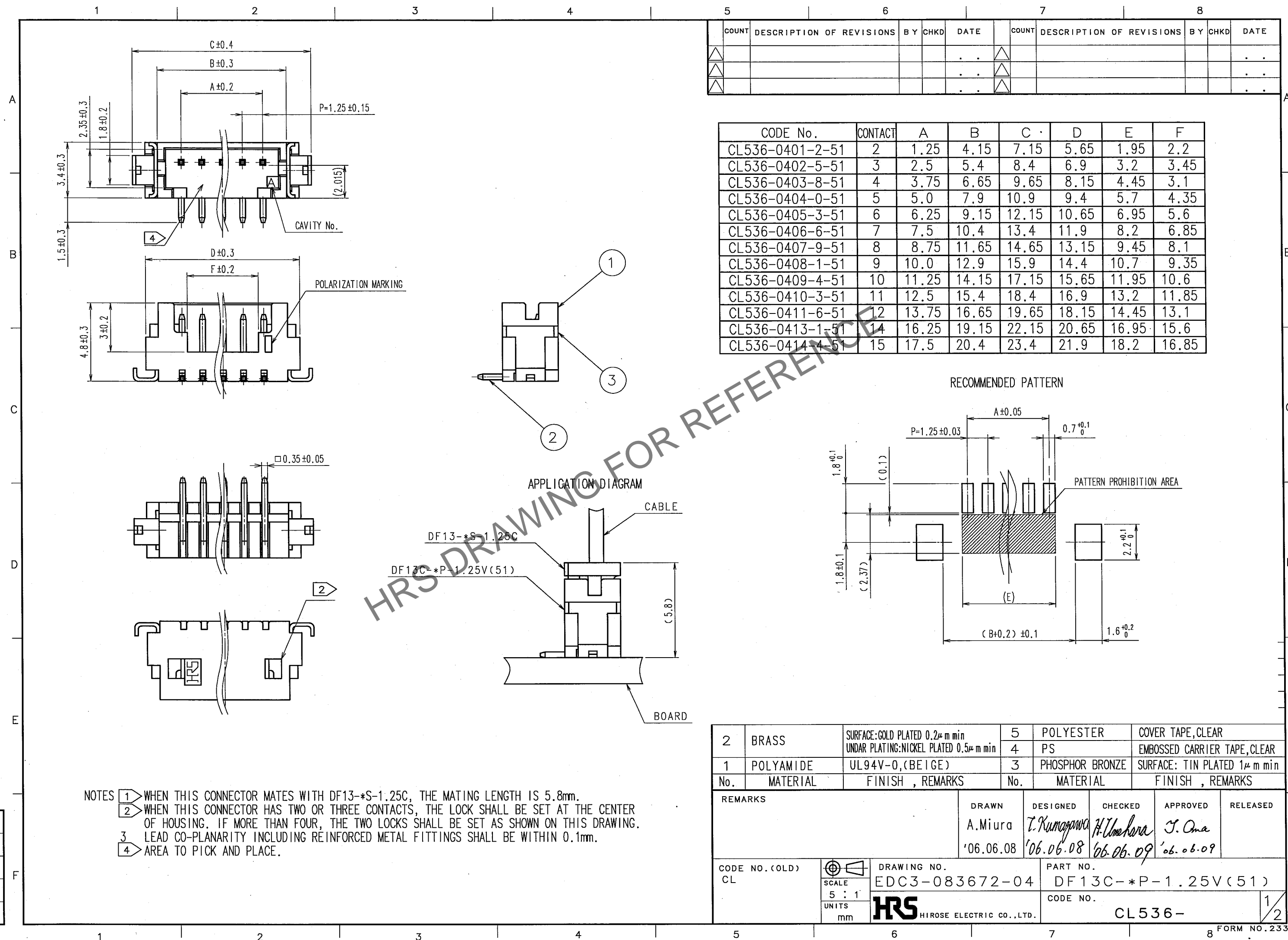

COUNT	DESCRIPTION OF REVISIONS	BY	CHKD	DATE	COUNT	DESCRIPTION OF REVISIONS	BY	CHKD	DATE
△					△				
△					△				
△					△				

CODE No.	CONTACT	A	B	C	D	E	F
CL536-0401-2-51	2	1.25	4.15	7.15	5.65	1.95	2.2
CL536-0402-5-51	3	2.5	5.4	8.4	6.9	3.2	3.45
CL536-0403-8-51	4	3.75	6.65	9.65	8.15	4.45	3.1
CL536-0404-0-51	5	5.0	7.9	10.9	9.4	5.7	4.35
CL536-0405-3-51	6	6.25	9.15	12.15	10.65	6.95	5.6
CL536-0406-6-51	7	7.5	10.4	13.4	11.9	8.2	6.85
CL536-0407-9-51	8	8.75	11.65	14.65	13.15	9.45	8.1
CL536-0408-1-51	9	10.0	12.9	15.9	14.4	10.7	9.35
CL536-0409-4-51	10	11.25	14.15	17.15	15.65	11.95	10.6
CL536-0410-3-51	11	12.5	15.4	18.4	16.9	13.2	11.85
CL536-0411-6-51	12	13.75	16.65	19.65	18.15	14.45	13.1
CL536-0413-1-51	14	16.25	19.15	22.15	20.65	16.95	15.6
CL536-0414-4-51	15	17.5	20.4	23.4	21.9	18.2	16.85

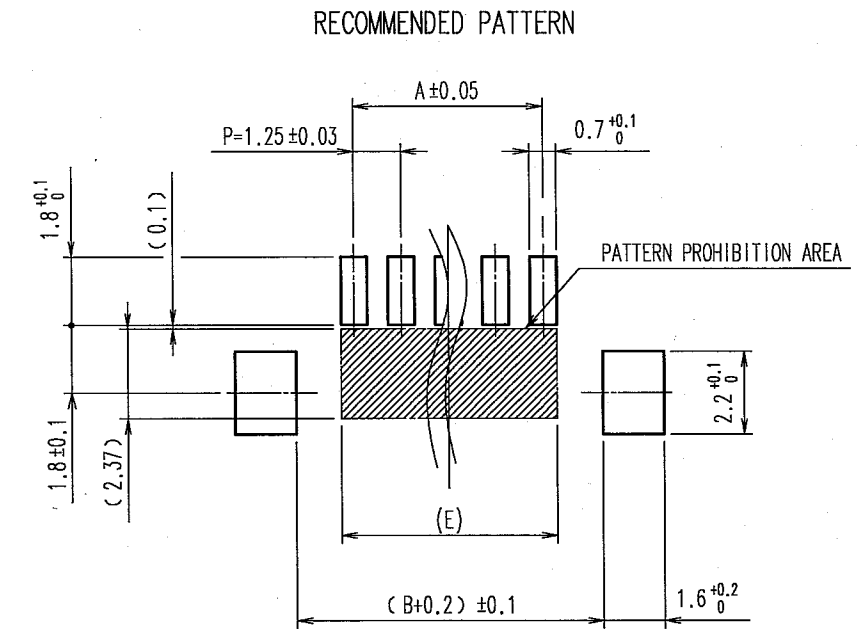

HRS DRAWING FOR REFERENCE

- NOTES
- 1 WHEN THIS CONNECTOR MATES WITH DF13-*S-1.25C, THE MATING LENGTH IS 5.8mm.
 - 2 WHEN THIS CONNECTOR HAS TWO OR THREE CONTACTS, THE LOCK SHALL BE SET AT THE CENTER OF HOUSING. IF MORE THAN FOUR, THE TWO LOCKS SHALL BE SET AS SHOWN ON THIS DRAWING.
 - 3 LEAD CO-PLANARITY INCLUDING REINFORCED METAL FITTINGS SHALL BE WITHIN 0.1mm.
 - 4 AREA TO PICK AND PLACE.

2	BRASS	SURFACE: GOLD PLATED 0.2μm min UNDAR PLATING: NICKEL PLATED 0.5μm min	5	POLYESTER	COVER TAPE, CLEAR
1	POLYAMIDE	UL94V-0, (BEIGE)	4	PS	EMBOSSED CARRIER TAPE, CLEAR
No.	MATERIAL	FINISH, REMARKS	No.	MATERIAL	FINISH, REMARKS
REMARKS			DRAWN	DESIGNED	CHECKED
			A.Miura	T.Kumagawa	H.Umehara
			'06.06.08	'06.06.08	'06.06.09
			APPROVED	RELEASED	
			J. Oma		
			'06.06.09		
CODE NO. (OLD)	SCALE	DRAWING NO.	PART NO.		
CL	5 : 1	EDC3-083672-04	DF13C-*P-1.25V(51)		
	UNITS	HRS	CODE NO.		
	mm	HIROSE ELECTRIC CO., LTD.	CL536-		

Nov.1.2024 Copyright 2024 HIROSE ELECTRIC CO., LTD. All Rights Reserved.
In case of consideration for using Automotive equipment / device which demand high reliability, kindly contact our sales window correspondents.

COUNT	DESCRIPTION OF REVISIONS	BY	CHKD	DATE	COUNT	DESCRIPTION OF REVISIONS	BY	CHKD	DATE

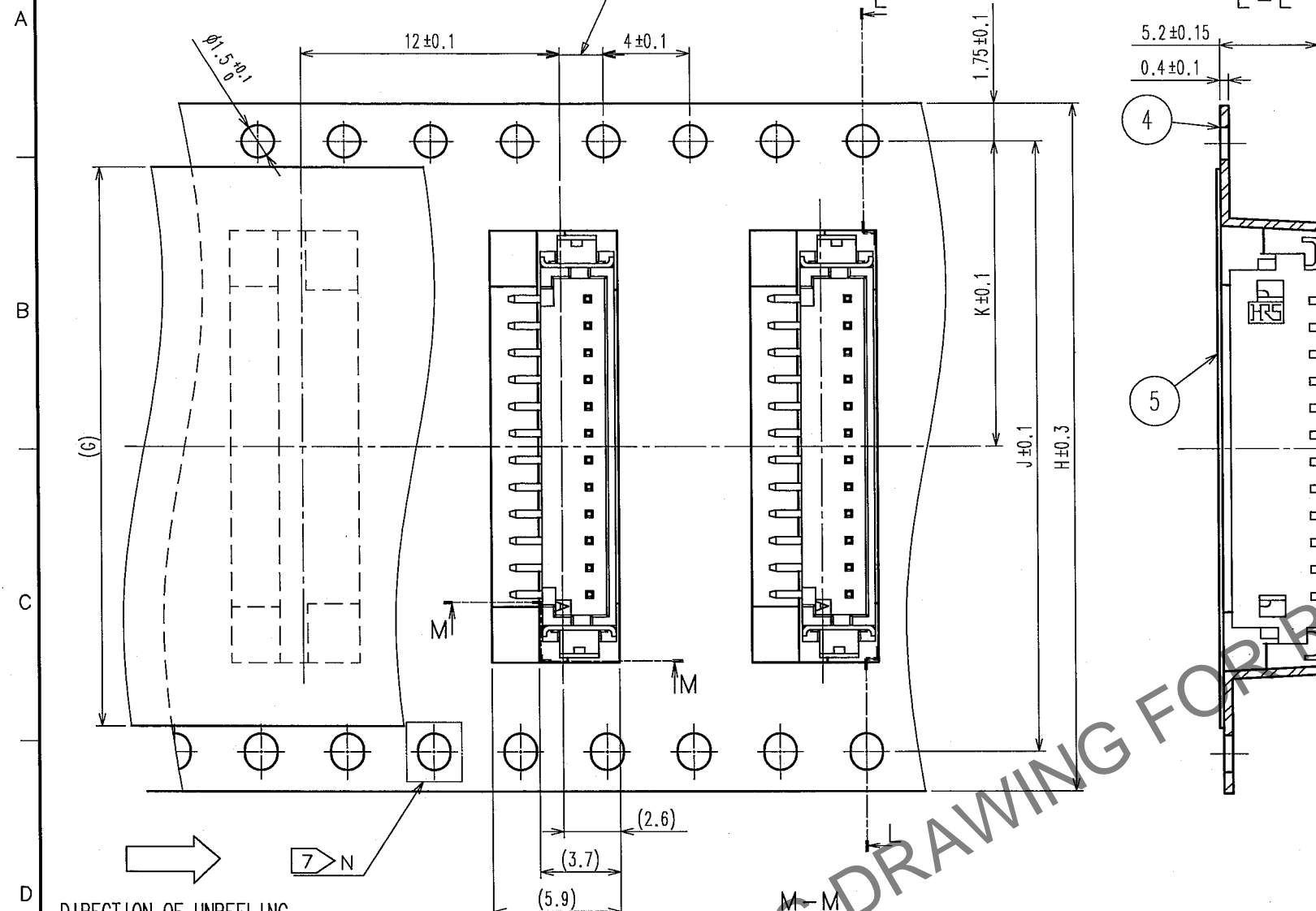

CODE No.	CONTACT	G	H	J	K	L
CL536-0401-2-51	2	13.5	16	/	7.5	16.4
CL536-0402-5-51	3	13.5	16	/	7.5	16.4
CL536-0403-8-51	4	21.5	24	/	11.5	24.4
CL536-0404-0-51	5	21.5	24	/	11.5	24.4
CL536-0405-3-51	6	21.5	24	/	11.5	24.4
CL536-0406-6-51	7	21.5	24	/	11.5	24.4
CL536-0407-9-51	8	21.5	24	/	11.5	24.4
CL536-0408-1-51	9	21.5	24	/	11.5	24.4
CL536-0409-4-51	10	21.5	24	/	11.5	24.4
CL536-0410-3-51	11	26	32	28.4	14.2	32.4
CL536-0411-6-51	12	26	32	28.4	14.2	32.4
CL536-0413-1-51	14	26	32	28.4	14.2	32.4
CL536-0414-4-51	15	37	44	40.4	20.2	44.4

9) DETAIL OF PART No. LABEL

DATE OF MANUFACTURED	年 月 日
CODE No.	
PART No.	DF13C-*P-1.25V(51)
QUANTITY	1000k o
SUPPLIER	HIROSE ELECTRIC CO.,LTD.

- NOTES
- 5 1REEL : 1000 CONNECTORS.
 - 6 AT THE BEGINNING OF THE REEL, 30 COMPONENTS SHALL BE EMPTY. AT THE END OF THE REEL, 20 COMPONENTS SHALL BE EMPTY.
 - 7 WHEN THE TAPE WIDTH IS 32 OR 44mm, SPROCKET HOLES SHALL BE SET ON BOTH SIDES OF REEL AS SHOWN ON THIS DRAWING.
 - 8 WHEN THE TAPE WIDTH IS 44mm OR OVER, THE TOLERANCE SHALL BE 2±0.15.
 - 9 DETAIL OF PART No. LABEL IS WRITTEN IN JAPANESE.
 - 10 PEEL FORCE BETWEEN EMBOSSED CARRIER TAPE AND COVER TAPE IS 0.1~0.7N.

STYLE AND DIMENSION OF REEL

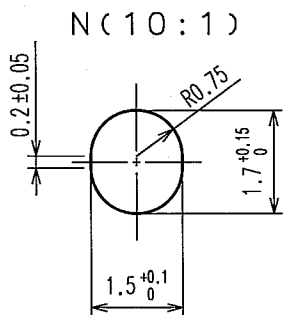
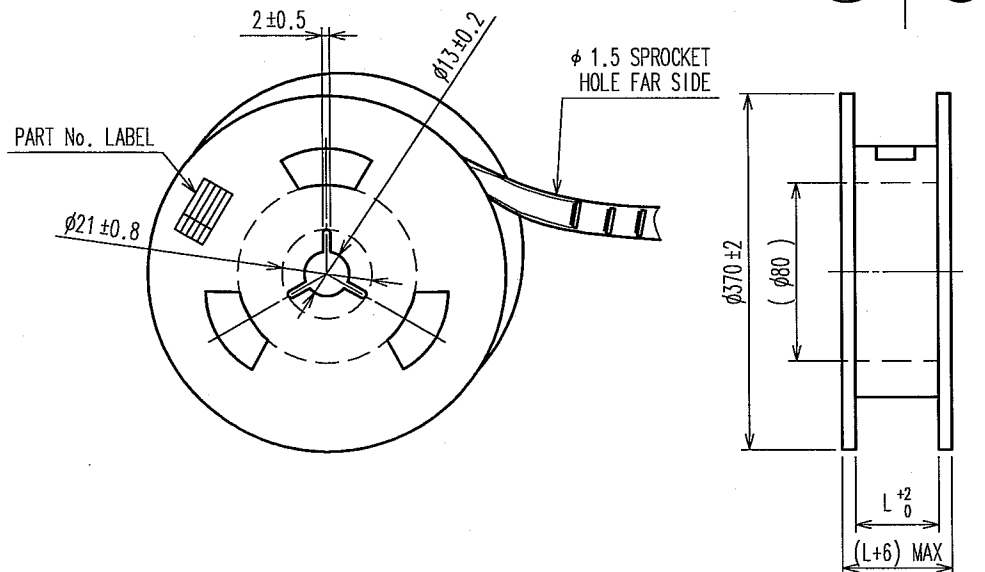

REMARKS	DRAWN	DESIGNED	CHECKED	APPROVED	RELEASED
	A.Miura '06.06.08	T.Kumagawa '06.06.08	H.Umehara '06.06.09	J.Oma '06.06.09	
CODE NO. (OLD)	DRAWING NO. EDC3-083672-04		PART NO. DF13C-*P-1.25V(51)		
SCALE FR:EE UNITS mm	HRS HIROSE ELECTRIC CO.,LTD.		CODE NO. CL536-		2