

Apr.1.2025 Copyright 2025 HIROSE ELECTRIC CO., LTD. All Rights Reserved.
 In case of consideration for using Automotive equipment / device which demand high reliability, kindly contact our sales window correspondents.

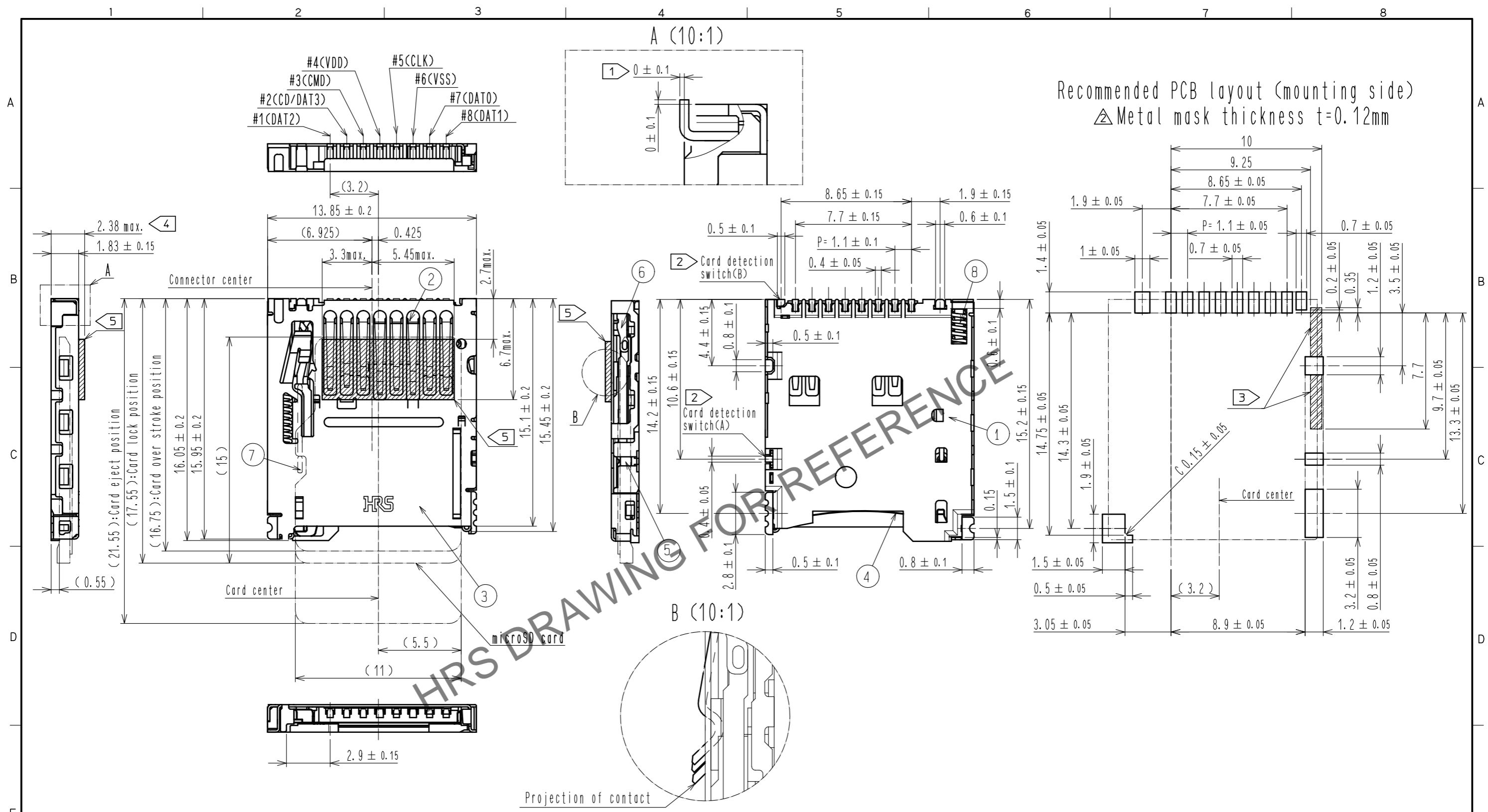

Notes ① Co-planarity shall be 0.1mm max.

② Card detection switch.

No card	Card inserted
Open	Close
(A) (B)	(A) (B)

- ③ :No patterns are permitted in this oblique-hatched area.
- ④ The production height of card mated condition shall be 2.38mm max.
- ⑤ Oblique-hatched area is projection of contact.

Added handling instructions.

4	Stainless steel		10	Polyester	
3	Stainless steel	Mounting area Ni0.5μm+Au0.03μm	9	PS	
2	Phosphor bronze	Contact area Ni3μm+Au0.1μm	8	Stainless steel	
		Mounting area Ni3μm+Au0.03μm	7	Stainless steel	
1	LCP	Black UL94V-0	5.6	Phosphor bronze	Contact area Ni1.5μm+Au0.1μm
					Mounting area Ni1.5μm+Au0.03μm
NO.	MATERIAL	FINISH . REMARKS	NO.	MATERIAL	FINISH . REMARKS
UNITS mm		SCALE FREE	COUNT 1	DESCRIPTION OF REVISIONS DIS-F-00021242	
APPROVED : KI. AKIYAMA 20080903			DESIGNED TY. EDAGAWA		
CHECKED : SI. TOMIOKA 20080903			CHECKED HT. YAMAGUCHI		
DESIGNED : KJ. NISHIWAKI 20080902			DATE 20240902		
DRAWN : KJ. NISHIWAKI 20080902			DRAWING NO. EDC-158563-00-00		
HRS HIROSE ELECTRIC CO., LTD.			PART NO. DM3BT-DSF-PEJS		
			CODE NO. CL0609-0029-9-00		

Apr.1.2025 Copyright 2025 HIROSE ELECTRIC CO., LTD. All Rights Reserved.
 In case of consideration for using Automotive equipment / device which demand high reliability, kindly contact our sales window correspondents.

6 Drawing for packing

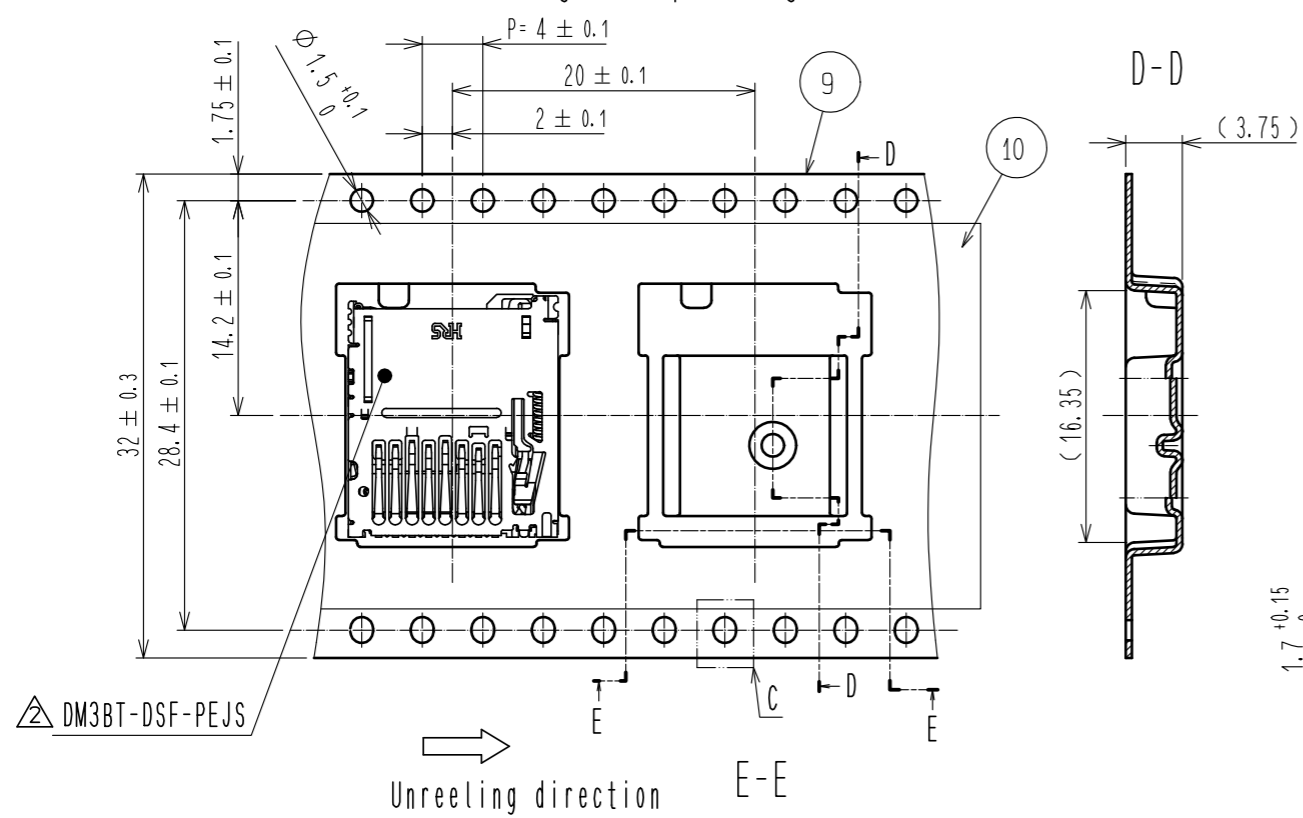

D-D

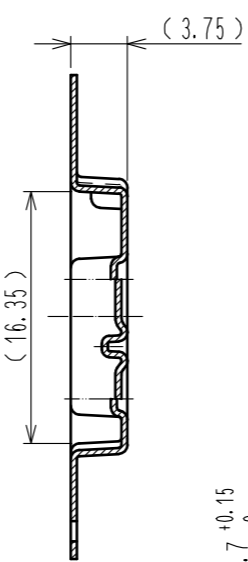

C (10:1)

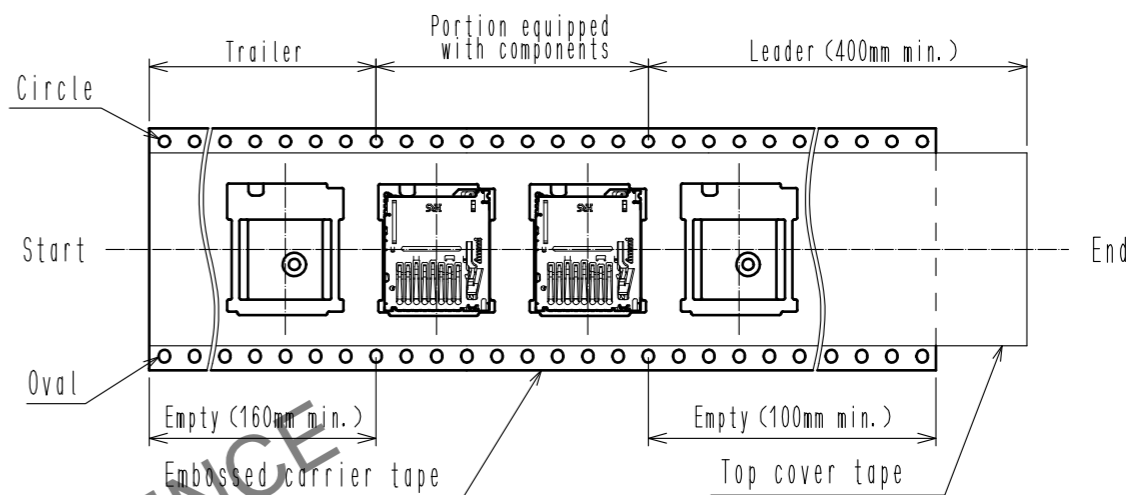
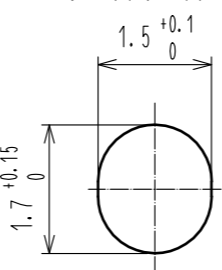

Unreeling direction

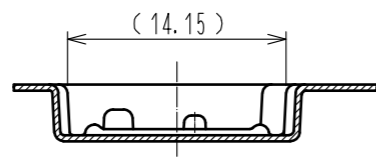

Detail of REEL (1:10)

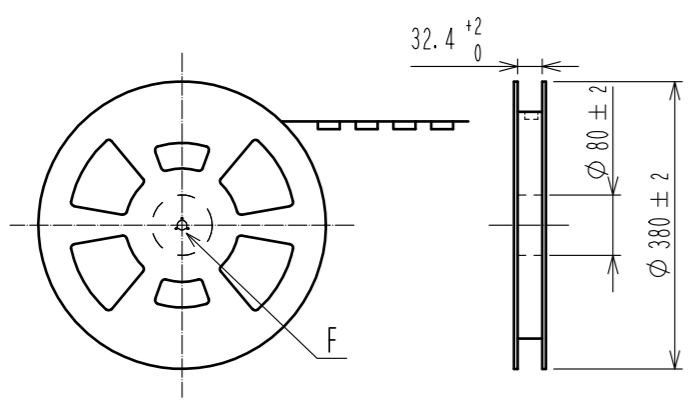

F (1:10)

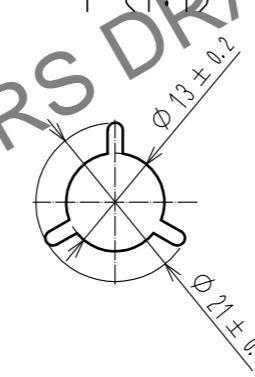

Recommended temperature profile

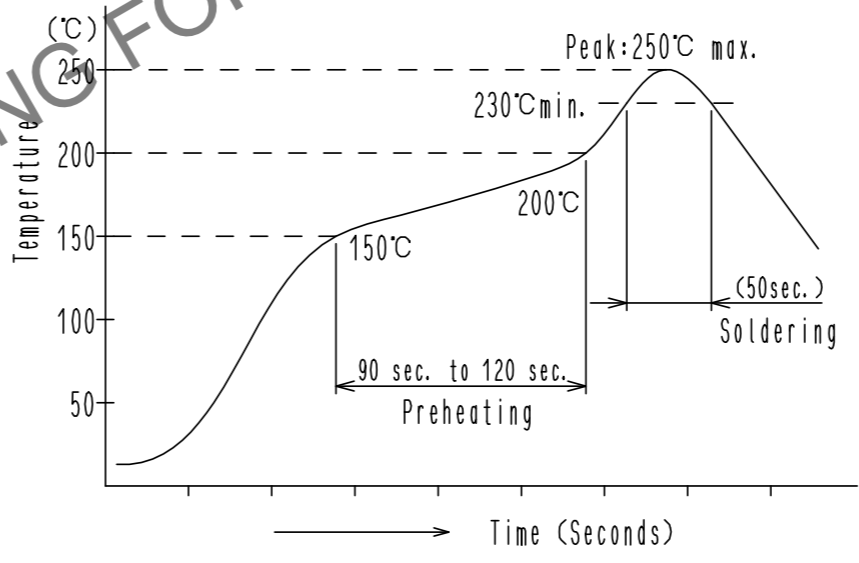

<Conditions>

- Reflow method : Combined far-IR and hot-air reflow
- Reflow atmosphere : Ambient air
- Solder : Cream type Sn/3.0Ag/0.5Cu
(M705-GRN360-K2-V made by Senju Kinzoku)
- Board tested : 60×100×1mm glass epoxy
- Metal mask thickness : 0.12mm
- Number of reflow cycles : Two cycles max

This temperature profile applies to the conditions stated above. Since temperature profiles can vary depending on the type and manufacturer of the cream solder used, as well as board size and other factors including conditions of the parts to be mounted, make sure to check the mounting conditions carefully before use.

7 Manufacturing Date

Year		Month		Date					
Year	Symbol	Month	Symbol	Date	Symbol	Date	Symbol	Date	Symbol
2020	0	Jan.	A	1	1	11	B	21	M
2021	1	Feb.	B	2	2	12	C	22	N
2022	2	Mar.	C	3	3	13	D	23	P
2023	3	Apr.	D	4	4	14	E	24	Q
2024	4	May	E	5	5	15	F	25	R
2025	5	Jun.	F	6	6	16	G	26	S
2026	6	Jul.	G	7	7	17	H	27	T
2017	7	Aug.	H	8	8	18	J	28	U
2018	8	Sep.	I	9	9	19	K	29	V
2019	9	Oct.	J	10	A	20	L	30	W
		Nov.	K					31	X
		Dec.	L						

Notes 6 Packing type : TAPE and REEL. 1200PCS per REEL.

- (Delete note)
- 7 Lot. No. shall be indicated as shown.

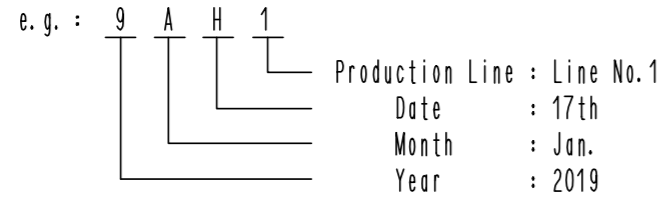

HRS	DRAWING NO.	EDC-158563-00-00
	PART NO.	DM3BT-DSF-PEJS
	CODE NO.	CL0609-0029-9-00

Apr.1.2025 Copyright 2025 HIROSE ELECTRIC CO., LTD. All Rights Reserved.
In case of consideration for using Automotive equipment / device which demand high reliability, kindly contact our sales window correspondents.

△ [Product information and handling instructions]

1. Contact timing

● Follow the following contact timing chart.

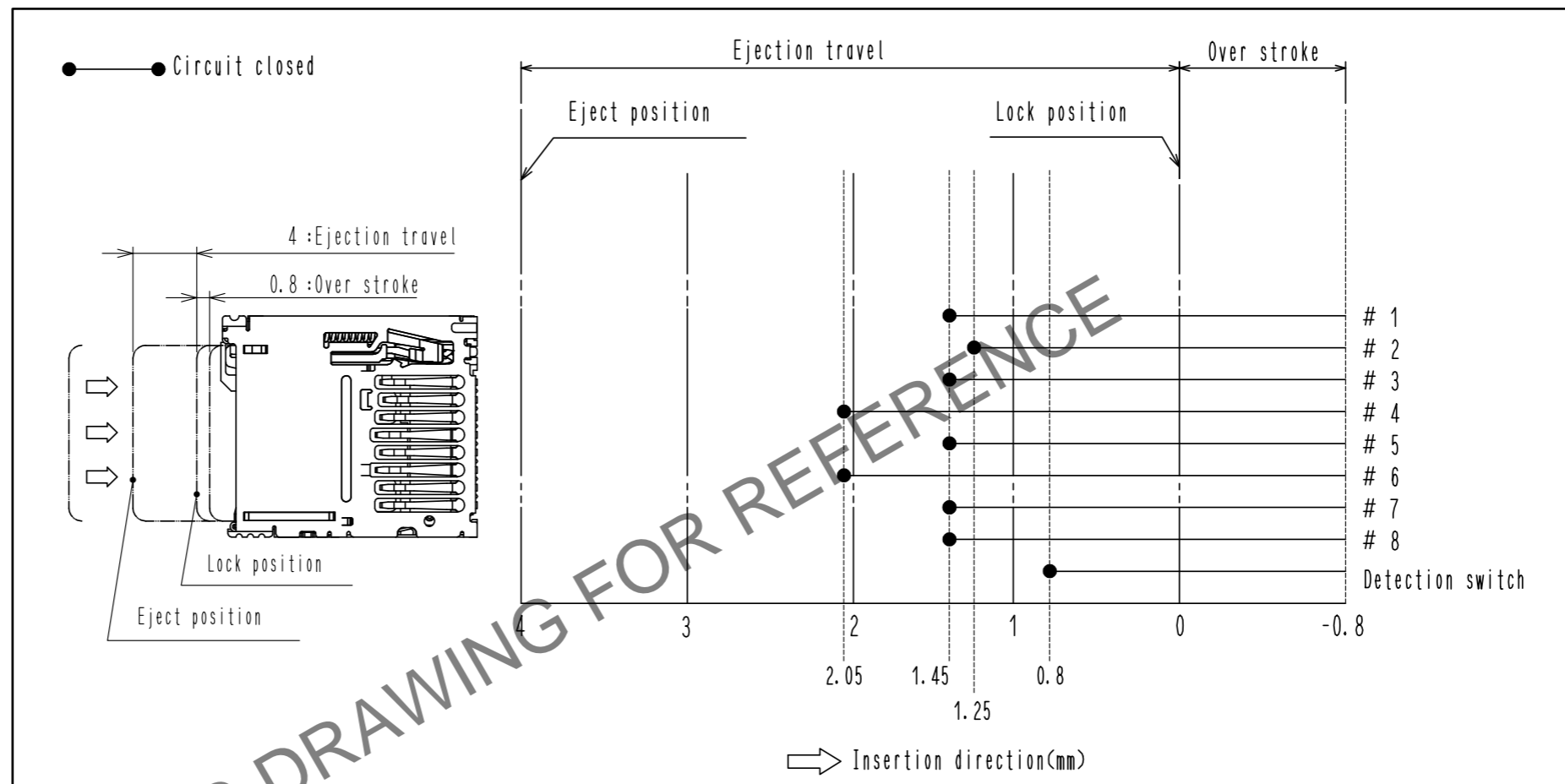

2. Area recommended for the application of surface mounting adhesive

● Make sure to apply adhesives in the applicable areas shown in the drawing below. Avoid the use of adhesives in other areas as this can lead to functional problems. Do not apply excessive amounts of adhesive as this can cause the product to "float" which may in turn cause solder failure. Make sure to use only the smallest amount of adhesive possible.

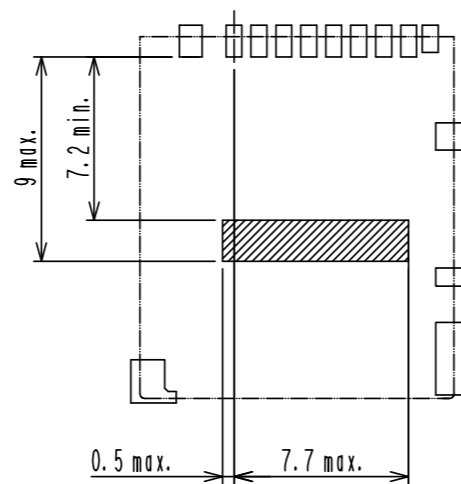

Recommended adhesive SOMAKOTE IR-010H-3

(Made by Somar Corporation)

HRS	DRAWING NO.	EDC-158563-00-00
	PART NO.	DM3BT-DSF-PEJS
	CODE NO.	CL0609-0029-9-00

△ 3/7

Apr.1.2025 Copyright 2025 HIROSE ELECTRIC CO., LTD. All Rights Reserved.
In case of consideration for using Automotive equipment / device which demand high reliability, kindly contact our sales window correspondents.

3. Attachable area on the upper side

- The shaded area shown in the drawing below designates the area where the product can be pressed on from the upper side using the enclosure.

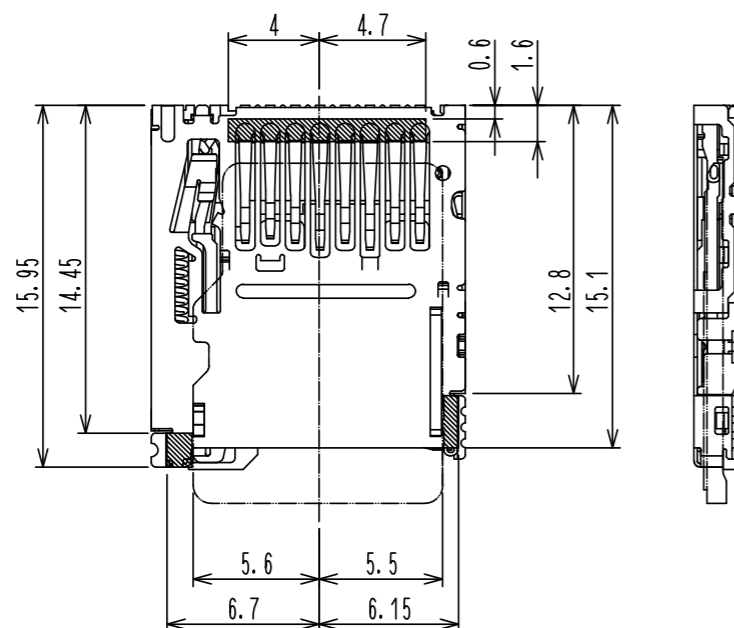

4. Range of contact tip's external protrusion

- The shaded area shown in the drawing below designates the area of the contact tip that protrudes to the connector's exterior when the card is inserted. The metal cover has two protrusions for guiding purposes. Make sure these are not subjected to external pressure such as that from the enclosure.

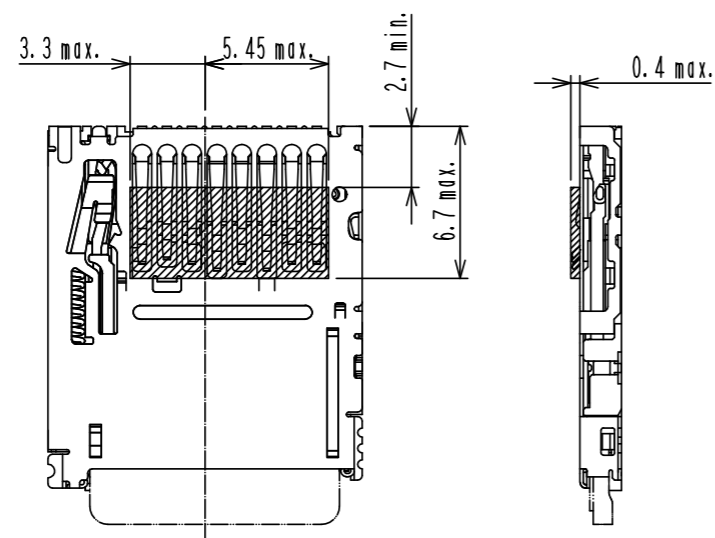

5. Recommended enclosure dimensions

- Recommended enclosure dimensions
For better card insertability, we recommend the enclosure dimensions shown on pages 6-7.
- Recommended dimensions for attaching a cover (lid)
Please install a cover (lid) to prevent the card from falling or becoming misplaced due to unforeseen causes.
The following dimensions are recommended for attaching a cover (lid).

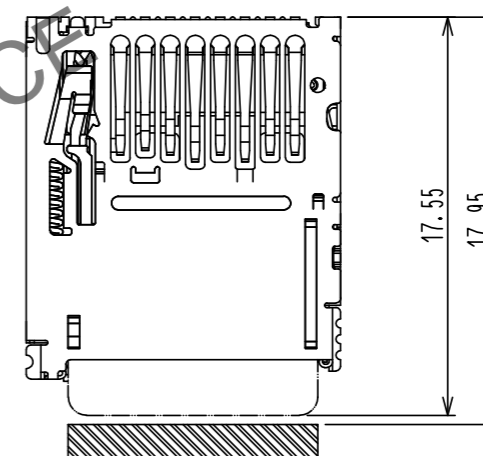

- Markings for preventing incorrect card insertion
If you will be displaying markings or instructions to prevent end users from inserting the card incorrectly, please pay extra attention to the text description and the direction of the marking used to indicate the correct direction.

HRS	DRAWING NO.	EDC-158563-00-00
	PART NO.	DM3BT-DSF-PEJS
	CODE NO.	CL0609-0029-9-00
		3/47

Apr.1.2025 Copyright 2025 HIROSE ELECTRIC CO., LTD. All Rights Reserved.
In case of consideration for using Automotive equipment / device which demand high reliability, kindly contact our sales window correspondents.

6. Reminders

(1) This product is equipped with an ejection function.
Never wash the entire connector as this could lead to problems with this function.
If it must be washed, wash only the soldered areas and make sure that you do not leave any cleaner residues on the connector. Cleaner residues can cause problems with card insertion/extraction and electrical performance.

(5) The connector's detection contact is exposed due to its low profile design.
Please handle with care.

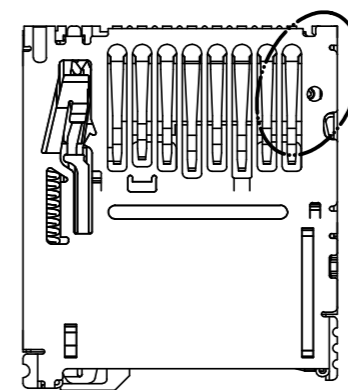

(2) Lubricant is applied to this product in order to improve sliding property.
Lubricant may adhere to the cover due to its appearance, but this does not affect its function.
Due to the manufacturing process, traces of press oil may remain on the cover, but this does not affect its function.

(3) If you will be performing card recognition and operating inspections in your assembly process, please pay attention to the points listed below.
If any of these points do not meet requirements, use a new card to perform your inspections.

- Outer dimensions must be within specifications.
Pay particular attention not to use products that have become off-spec due to wear.
- Make sure that there is no severe wear on the pad (base material must not be exposed).

Important outer dimensions
for microSD CARD standard

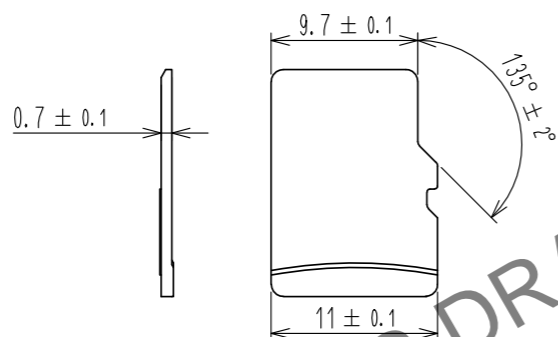

(4) Excessive force may cause the connector to fail or become damaged.
Please handle the connector with care and make sure that it does not deform in any way.
In particular, avoid the following if you will be performing card recognition and operating inspections in your assembly process without installing the product to an enclosure.

(6) This is a connector designed to be mounted on boards.
Make sure not to use the connector on its own as this could lead to functional problems.

(7) This is a connector for microSD card. Do not insert other types of cards.
Make sure not to insert the card in the wrong direction, at an angle, or forcibly.
This product is equipped with a function for preventing users from inserting cards in the wrong direction, but damage may occur to the card and/or connector if the card is forcibly inserted in the wrong direction.

(8) Please do not use a prying motion to withdraw an engaged card.
This can cause damage to the card and/or connector.

(9) Due to the material used, the surface of a card will be subject to sliding scratches but this will not affect product quality or performance.

(10) Cards are designed to withstand a bending strength of up to 10N.
Please handle cards with care to prevent damage.

- Do not insert or withdraw cards at an angle, whether in a vertical or lateral direction.
- Do not insert or withdraw a partially inserted card by prying it in a vertical or lateral direction.

(11) The following drawing shows the adsorbing position for this product.

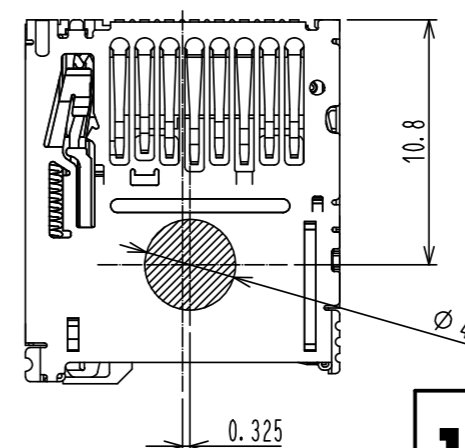
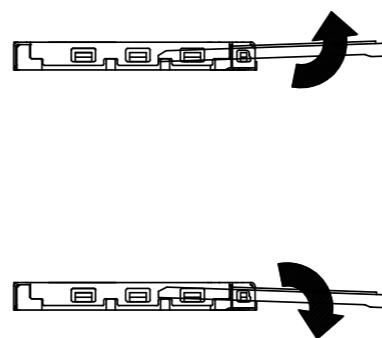
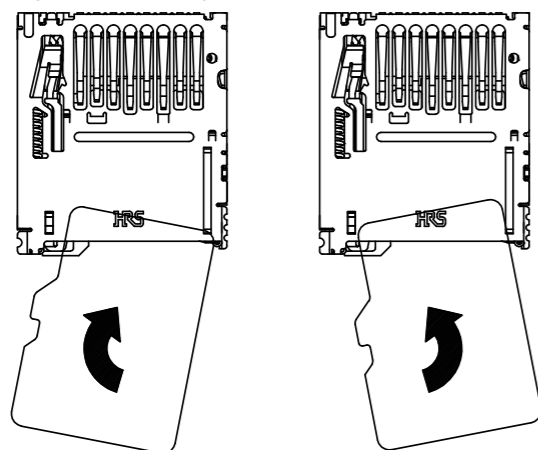

HRS

DRAWING NO.	EDC-158563-00-00
PART NO.	DM3BT-DSF-PEJS
CODE NO.	CL0609-0029-9-00

3/5/7

Apr.1.2025 Copyright 2025 HIROSE ELECTRIC CO., LTD. All Rights Reserved.
In case of consideration for using Automotive equipment / device which demand high reliability, kindly contact our sales window correspondents.

(12) Recommended enclosure dimensions

We recommend that the enclosure be designed as shown in the drawing below with a protective guide at the end of the ejector to improve card insertability, reduce connector wear which is often caused by forced insertions, and to prevent damage.

(I) Installed on the side

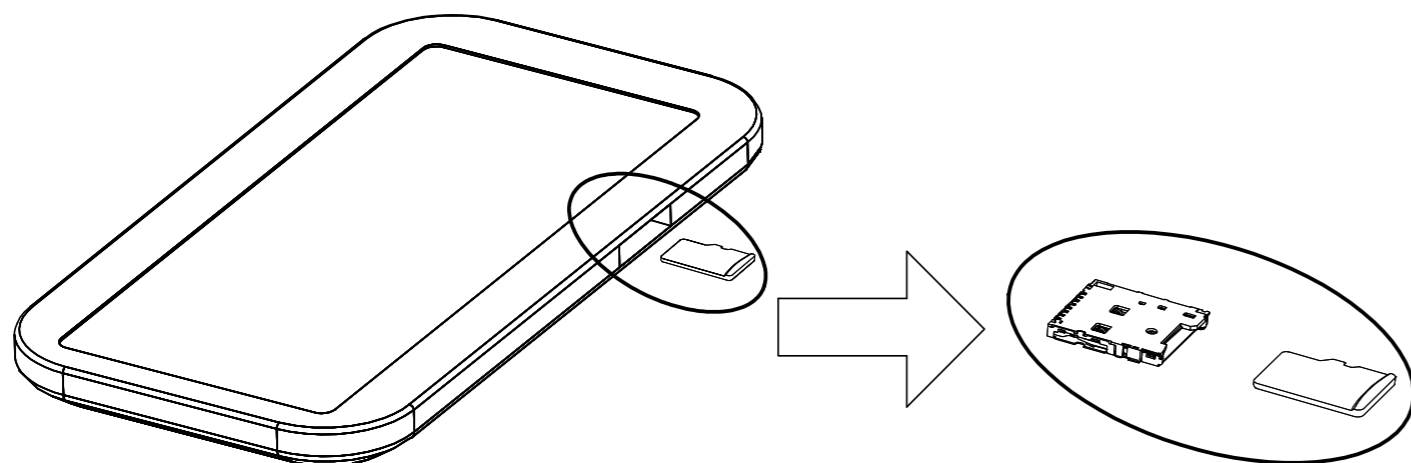

Connector layout

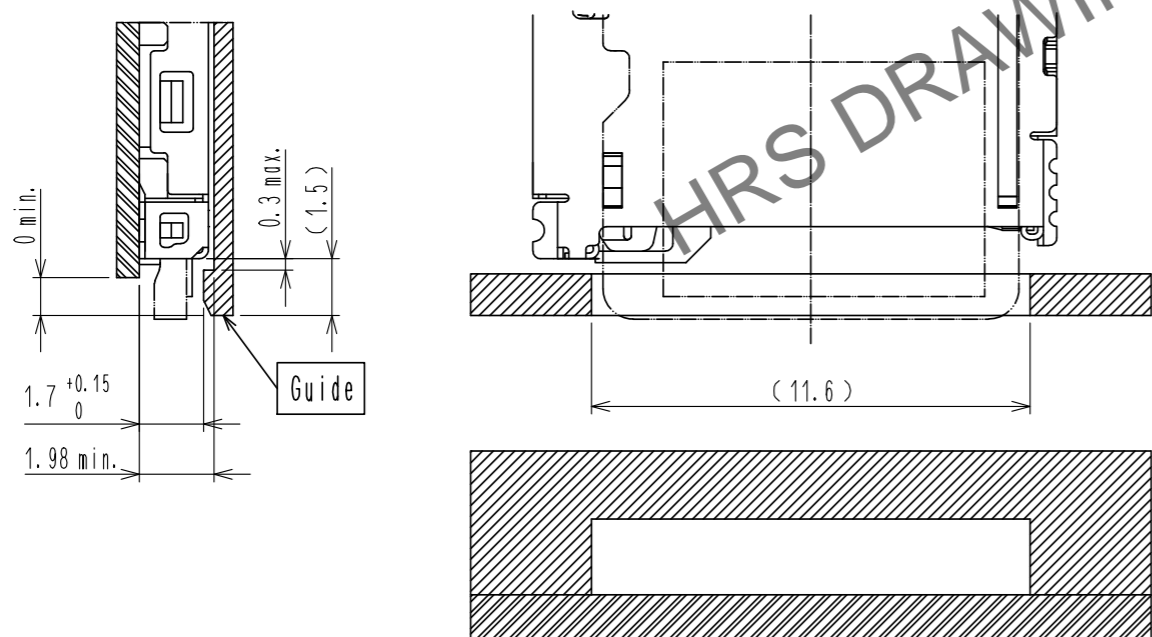

(II) Located near the battery at the rear

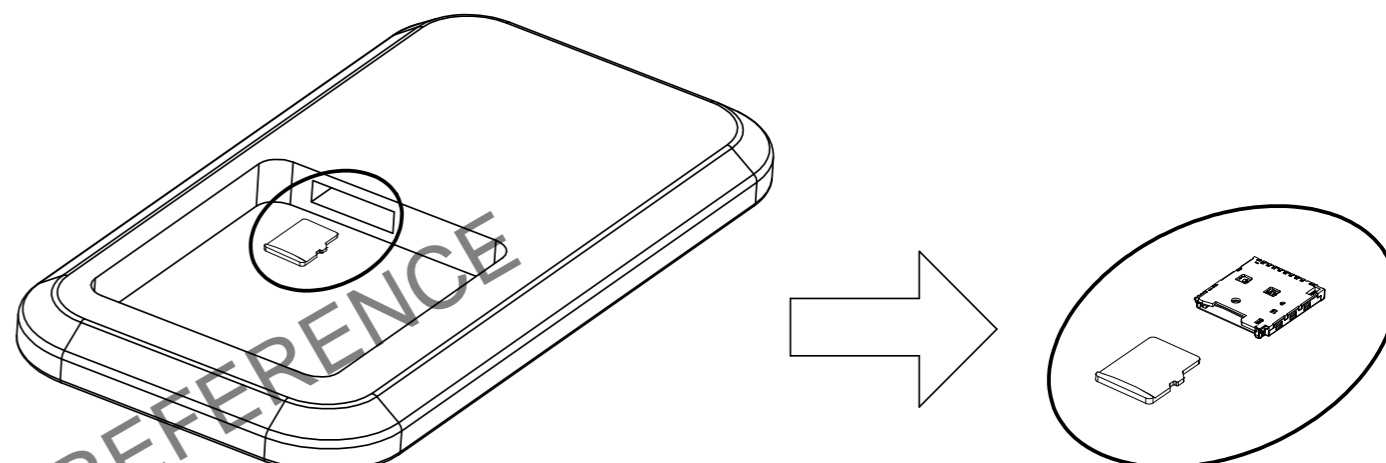

Connector layout

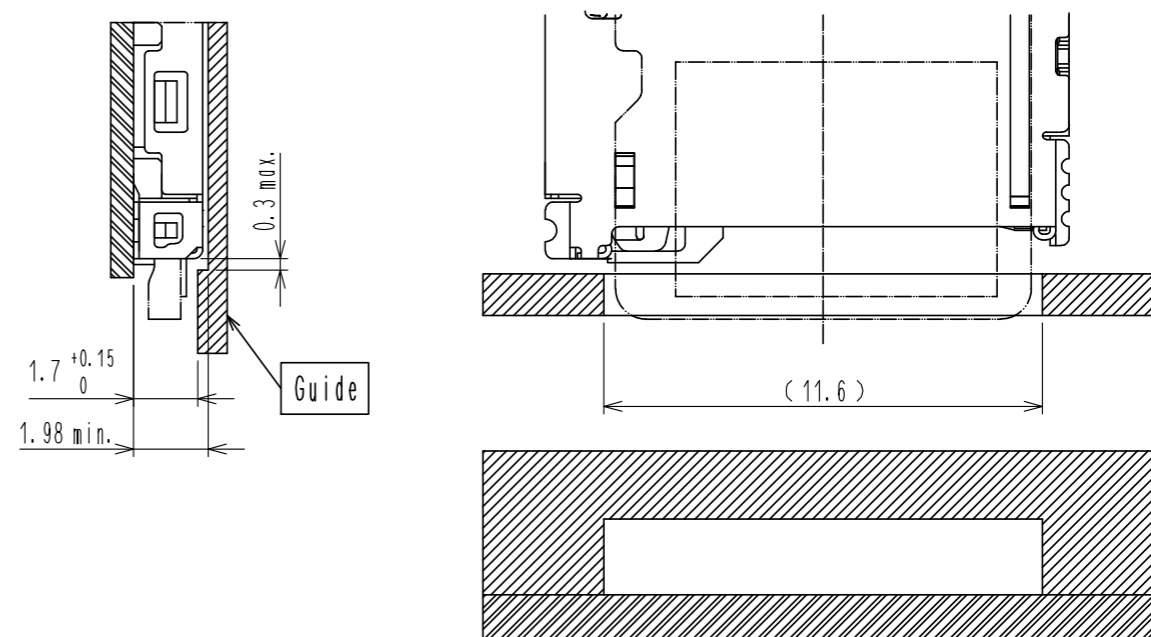

HRS	DRAWING NO.	EDC-158563-00-00
	PART NO.	DM3BT-DSF-PEJS
	CODE NO.	CL0609-0029-9-00
		3/67

Apr. 1. 2025 Copyright 2025 HIROSE ELECTRIC CO., LTD. All Rights Reserved.
In case of consideration for using Automotive equipment / device which demand high reliability, kindly contact our sales window correspondents.

We recommend that you design your enclosure with a "finger indent" as shown in the drawing below to facilitate card withdrawal.
If the center point of the finger indent must be placed off-center of the card, it may be off-center only in the direction shown in the first example shown below. This is to prevent the card from being inserted or withdrawn at an angle.

If you are unable to install a guide for the entire width of the slot due to design constraints, we recommend that you install a guide for at least the area shown in the drawing below.

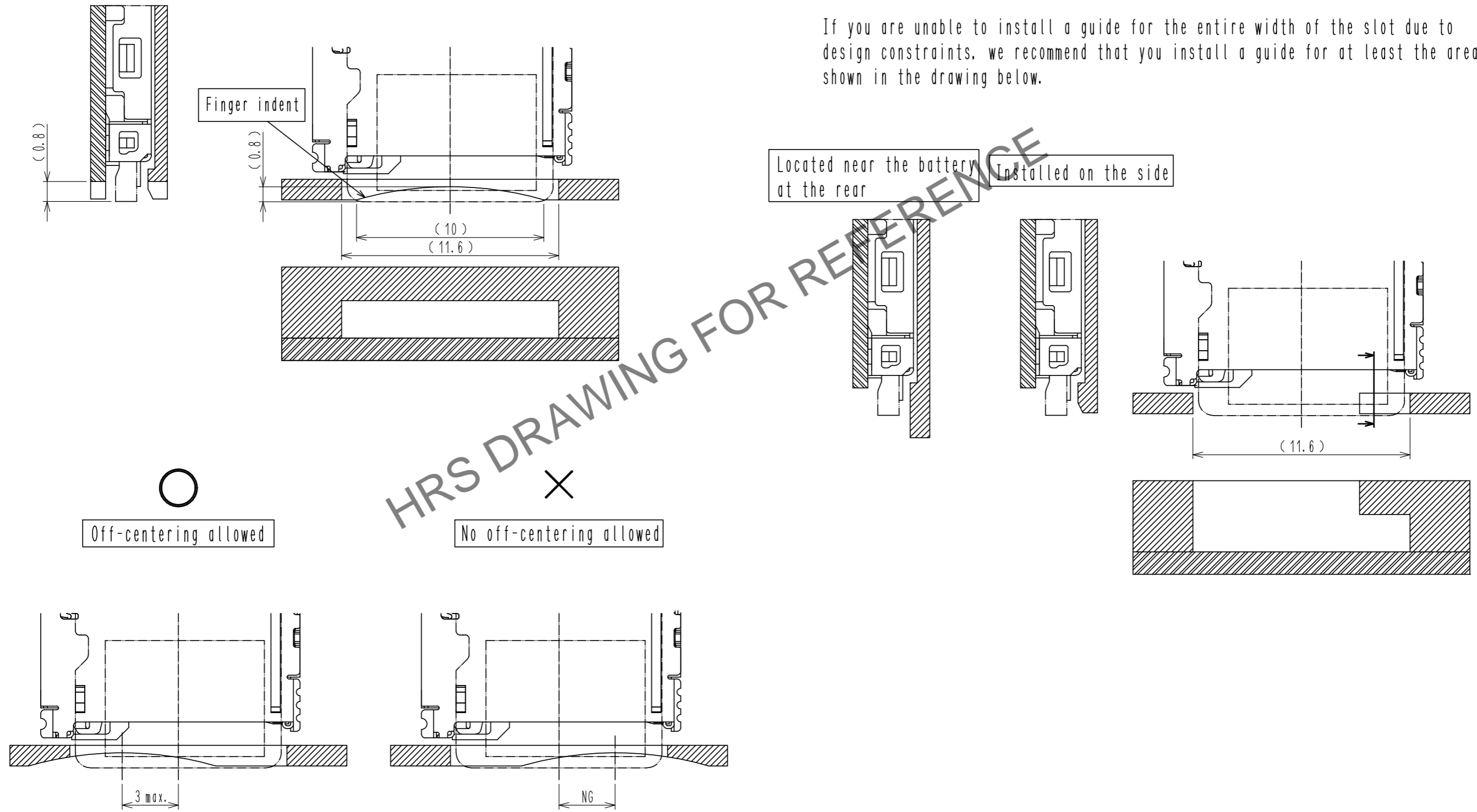

HRS DRAWING FOR REFERENCE

HRS	DRAWING NO.	EDC-158563-00-00
	PART NO.	DM3BT-DSF-PEJS
	CODE NO.	CL0609-0029-9-00
		3/7