

1. Scope

This document specifies the procedures of mating / unmating operation for DF57H- * S-1.2C and DF57H- * P-1.2V (* : Number of position).

2. Part Number

Part No.	Description
DF57H- * S-1.2C	Socket
DF57H- * P-1.2V	Header
DF57-####SCF	Crimp contact

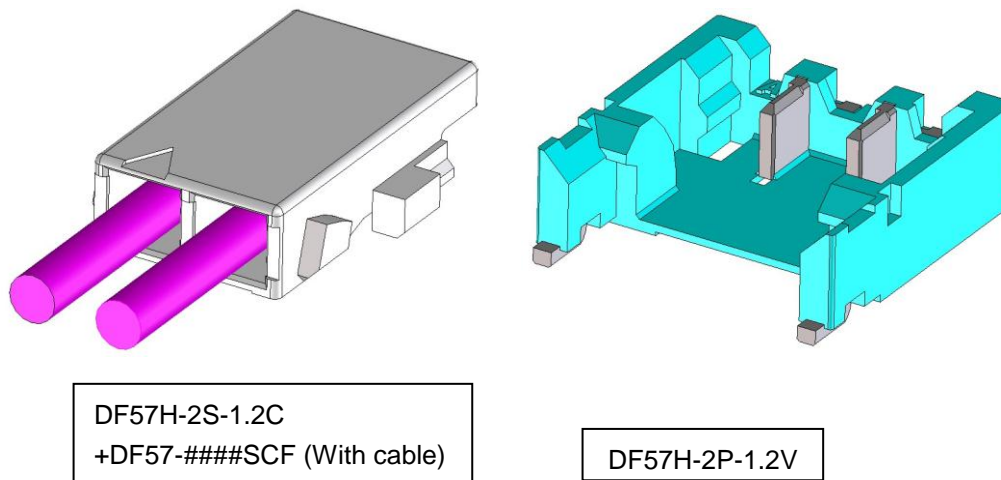

Fig. 1: DF57H Connector

3. Operation Procedures

3-1. Mating

3-1-a. Alignment for Mating

: By positioning the convexity of the socket sides to the header concavity, align the centers of the socket and the header in pitch direction.

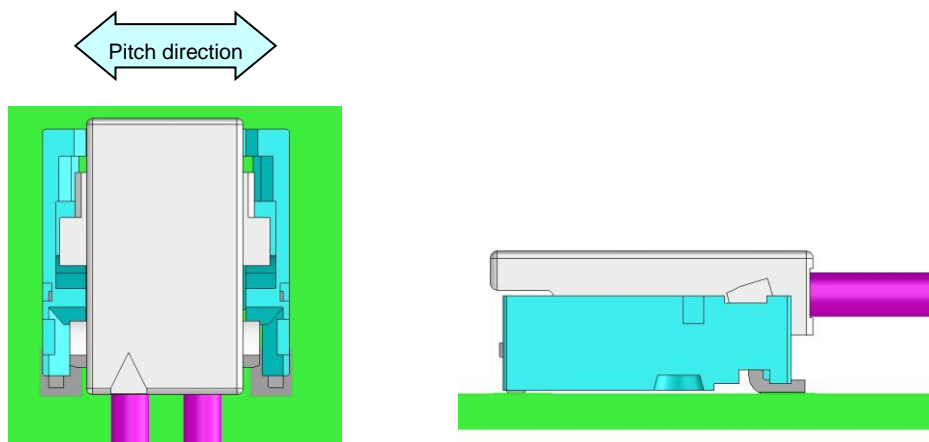

Fig. 2: Alignment for mating

COUNT	DESCRIPTION OF REVISIONS	DESIGNED	CHECKED	DATE
△ 3	DIS-H-00014677	HK. HAYASHI	SZ. ONO	20220725
TITLE			HIROSE ELECTRIC CO., LTD.	
DF57H Series Mating / Unmating Operation Instruction Manual				
APPROVED	KI. AKIYAMA	20120622		
CHECKED	HK. UMEHARA	20120622		
DESIGNED	TS. KUMAZAWA	20120621		
WRITTEN	TS. KUMAZAWA	20120621		
TECHNICAL SPECIFICATION			ETAD-H0652	△ 1 / 4

3-1-b. Temporary Insertion

: Slightly press the socket down at cable side to tilted angle.

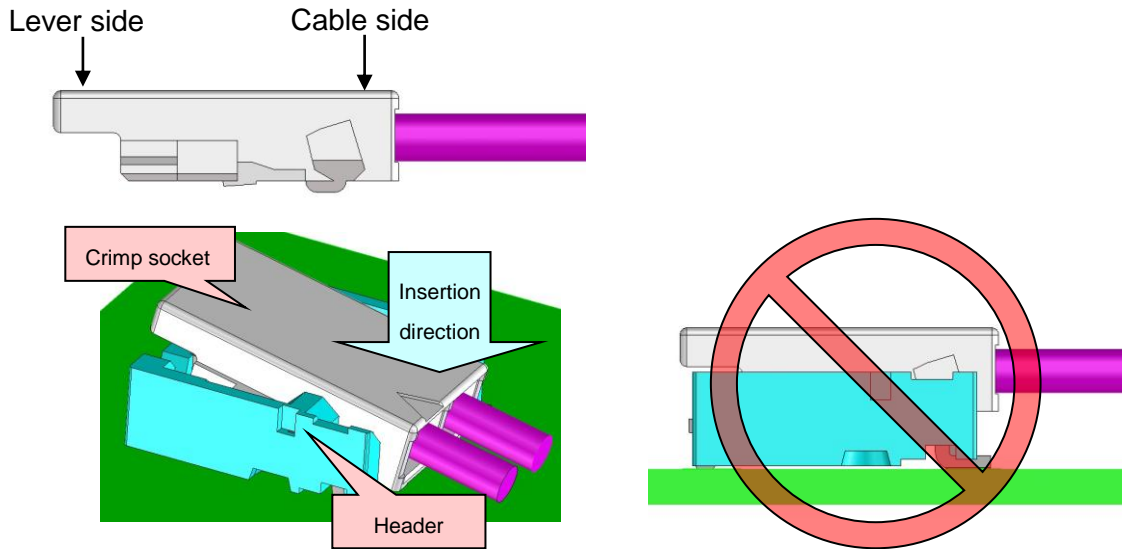

Fig. 3: Temporary insertion

If the crimp socket is pushed down horizontally without temporary insertion as shown above, the lock structure could be damaged, and lock strength could be lowered.

3-1-c. Mating

: Press down at the lever side with stabilizing the cable side to insert.

(If the socket at the cable side floats during mating, the lock could not work.)

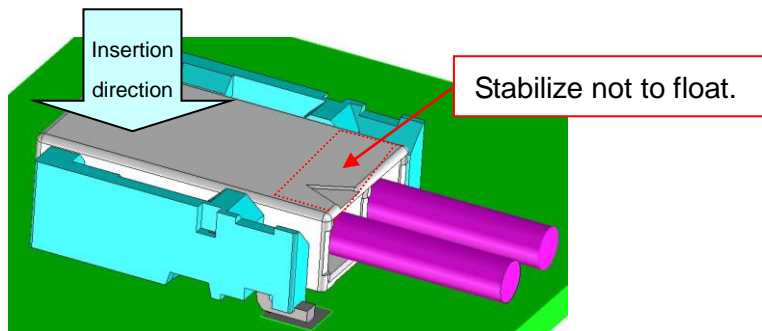

Fig. 4: Mating

Apply even force to the center of the socket in pitch direction for mating.

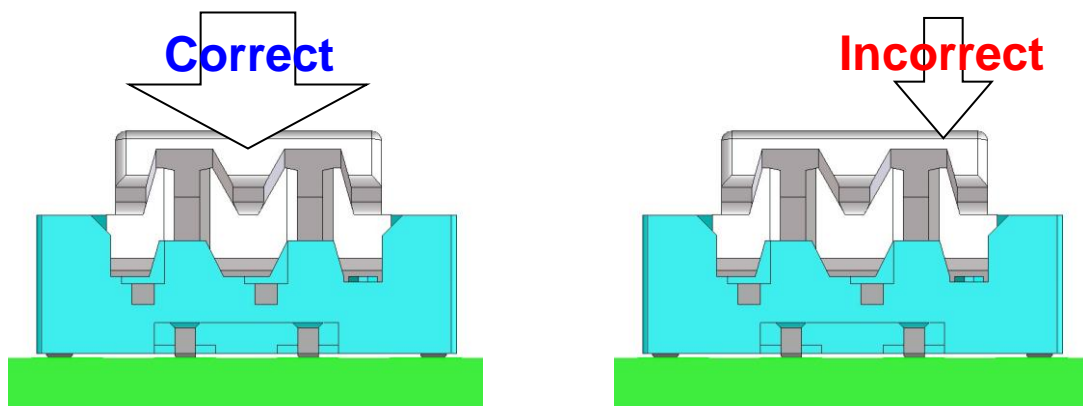



Fig. 5: Position to apply force

 Correction of errors

3-1-d. Mating Confirmation

: Make sure that the socket is completely mated.

If one side is floating or not completely mated, remove the socket from the header and insert again. Refer to 3-2. for removal operation.

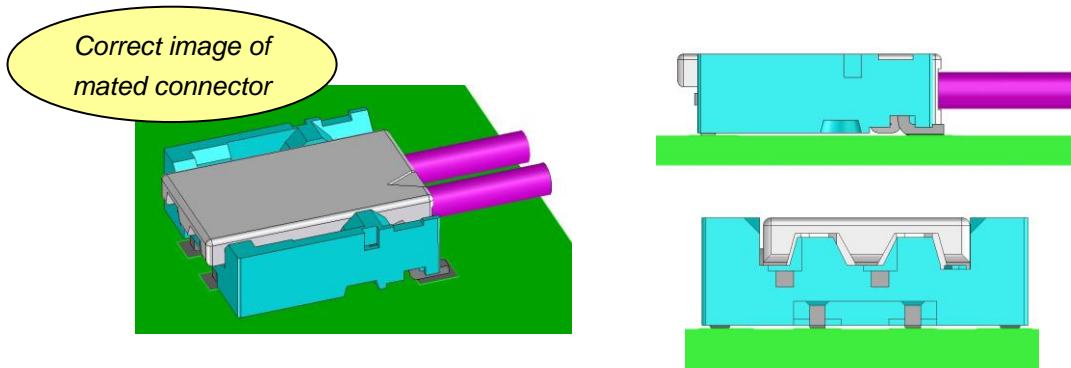

Fig. 6: Mating confirmation

3-2. Unmating

3-2-a. Unmating

: Hook the lever with finger nail and lift up to the upper direction for unlock.

NOTE) When lifting up the lever, do not apply downward force to the cable side of the socket. This could damage the connector.

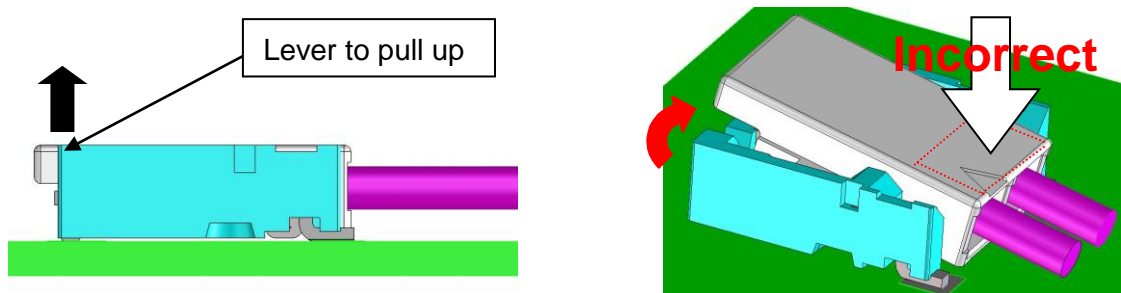

Fig. 7: Unmating

When pulling up the socket, apply even force to the center in pitch direction and do not operate at the corners.

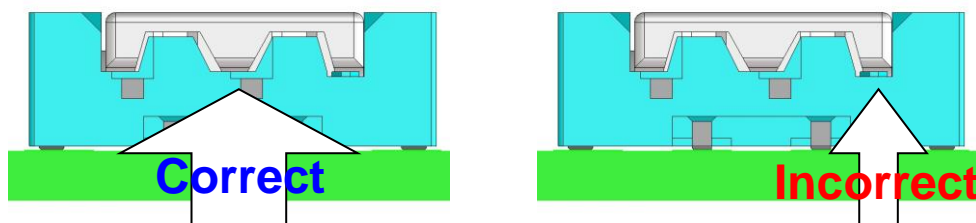

Fig. 8: Position to lift for unmating

Make sure to use the lever for removal operation.
If the cable is pull for removal, it could break the cable or damage the connector.

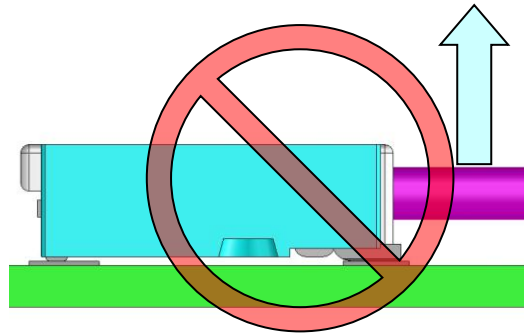

Fig. 9: Incorrect removal operation

4. Precautions

- Do not operate the connector while the electricity is carried.
- If excessive force is applied to the connector, failure or damage could be caused. Forcible mating / unmating, cable pull / cabling and mechanical shock, should be avoided.