

Mar.1.2026 Copyright 2026 HIROSE ELECTRIC CO., LTD. All Rights Reserved.
In case of consideration for using Automotive equipment / device which demand high reliability, kindly contact our sales window correspondents.

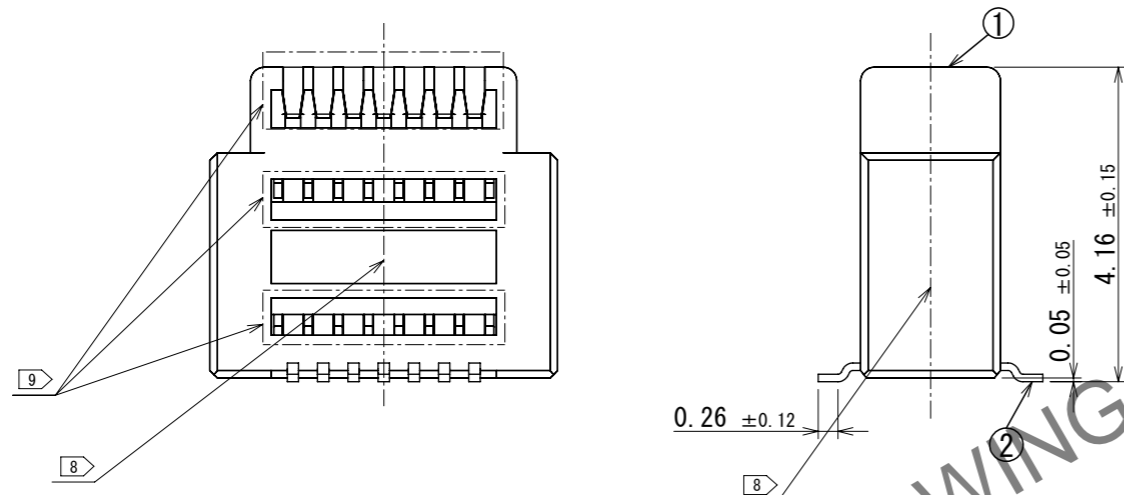

Recommended pattern

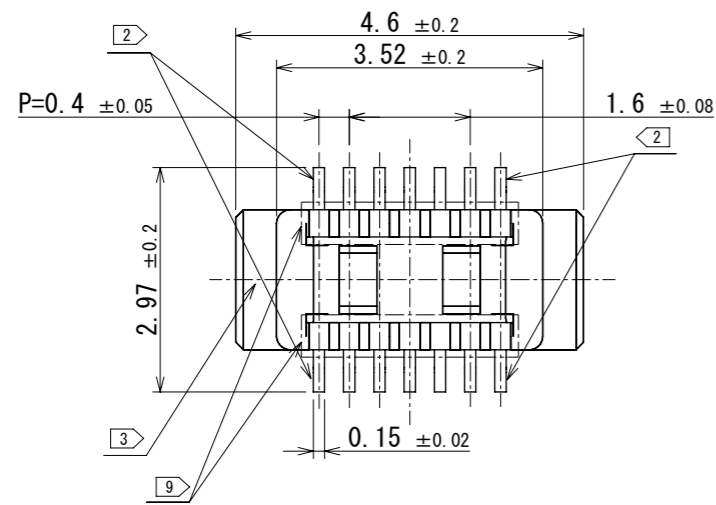
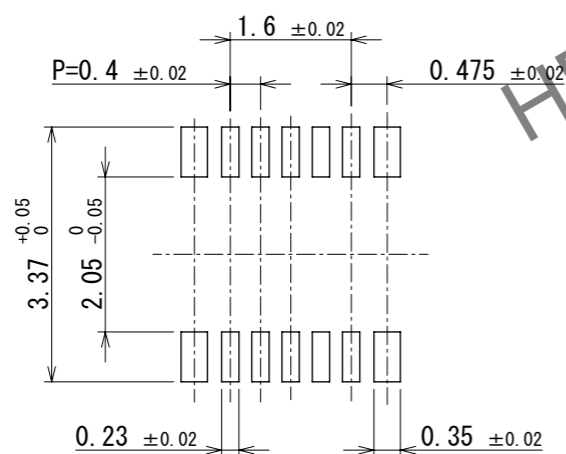

Recommended metal mask thickness: 120 μm
Recommended metal mask opening ratio: 80% for lead PAD

7 Recommended reflow temperature profile for lead-free solder.

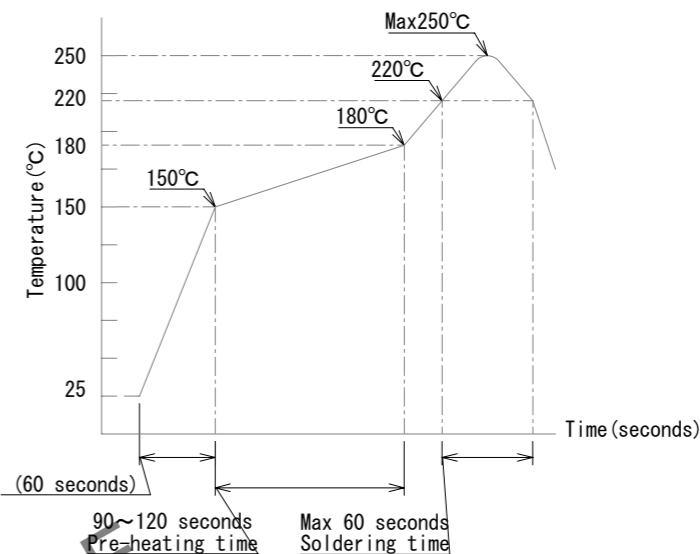

Reflow method : IR reflow
Number of reflow cycles : 2 cycles max.
1) Reflow time
Duration above 220°C, 60 sec max.
(peak temperature : 250°C max)

2) Pre-heat time
Pre-heat temperature (min) : 150°C
Pre-heat temperature (max) : 180°C
Pre-heat time : 90-120 sec.

△ Note

1. All lead co-planarity shall be 0.1mm max.
- 2 The terminals at the four corners should be used as metal fittings, which have no electrical continuity.
- 3 HRS mark and cavity No. are indicated.
- 4 Plating specifications
Contact area : Gold 0.05 μm min
SMT lead : Gold 0.05 μm min
Under plating : Nickel 1 μm min
(Surface : Sealing)
5. This product satisfies halogen free requirements defined as 900ppm max chlorine, 900ppm max bromine, and 1500ppm max total of chlorine and bromine.
6. This product complies with RoHS.
- 7 This temperature profile is based on the suggested metal mask and footprint. Please contact us if using different settings from our recommendation.
- 8 Weld line appears in the indicated position. This will not affect the connector's reliability.
- 9 The resin may overlap the top surface of the metal but will not affect the contact reliability.

PS	3	Clear, Embossed carrier tape	6	PS	Clear, Reinforcement collar
Copper alloy	2	4	5	PS	Black, Plastic reel
LCP	1	Black	4	Polyester	Clear, Cover tape
MATERIAL	NO.	FINISH, REMARKS	NO.	MATERIAL	FINISH, REMARKS
UNITS	mm	SCALE	10:1	COUNT	3
		DESCRIPTION OF REVISIONS		DESIGNED	JN MIYAURA
		DIS-H-00022795		CHECKED	YK. SATAKE
				DATE	2025. 03. 24
APPROVED : TY. OOI			2023. 06. 06		
CHECKED : RT. SHIMIZU			2023. 06. 06		
DESIGNED : RT. OSAKI			2023. 06. 06		
DRAWN : RT. OSAKI			2023. 06. 06		
DRAWING NO.				EDC-403740-51-00	
PART NO.				DF40TC (3. 0) -10DP-0. 4V (51)	
CODE NO.				CL0684-0033-0-51	

Mar.1.2026 Copyright 2026 HIROSE ELECTRIC CO., LTD. All Rights Reserved.
 In case of consideration for using Automotive equipment / device which demand high reliability, kindly contact our sales window correspondents.

Embossed carrier tape packaging (5:1)

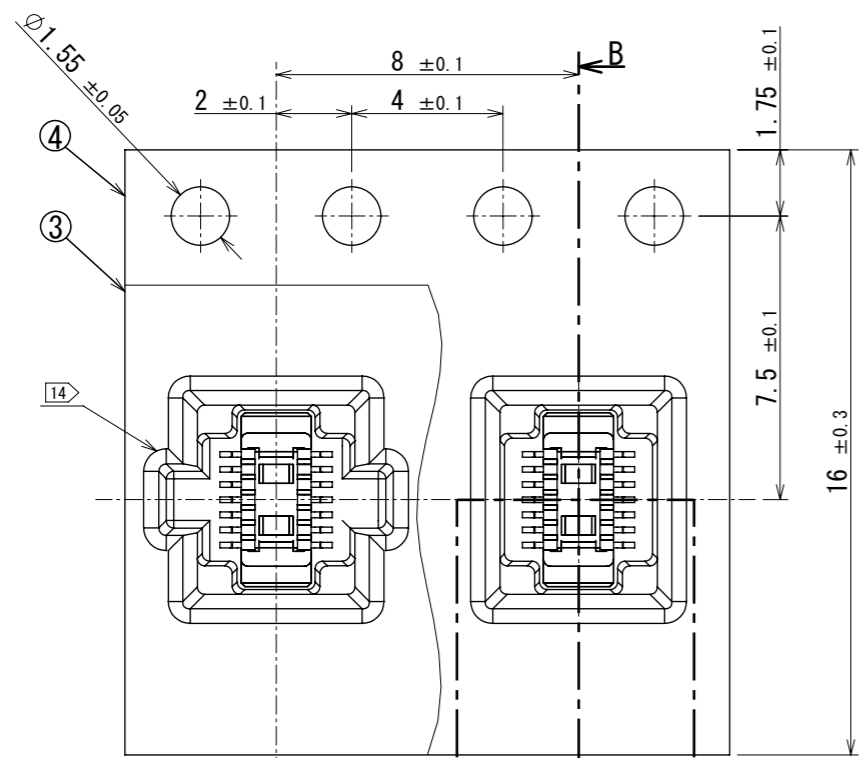

B-B
(5 : 1)

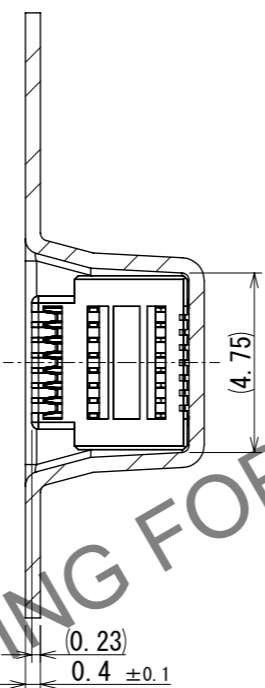

Style and dimension of reel (free)

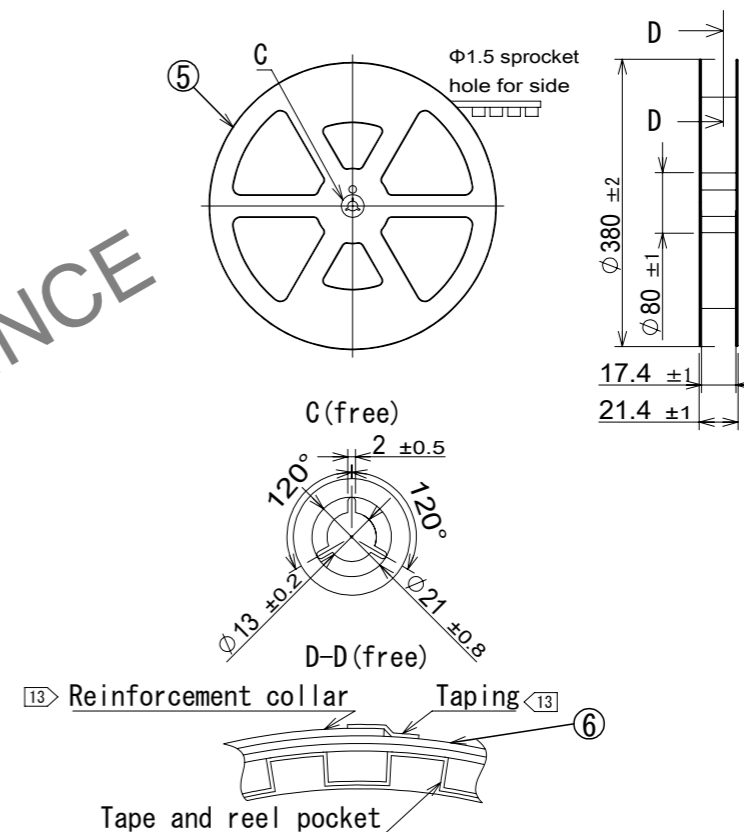

Direction of unreeling

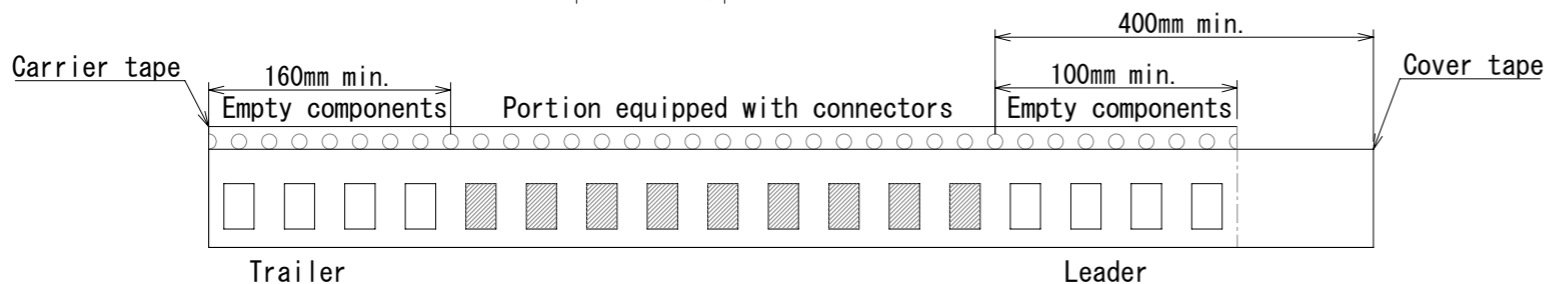
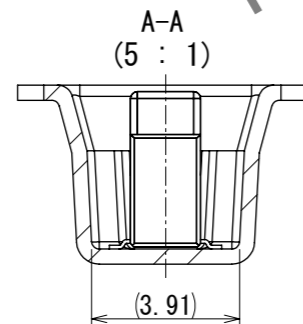

- ⑩. 2,000 connectors per reel.
- ⑪. The dimensions in parentheses are only for reference.
- ⑫. Refer to IEC 60286-3 (packaging of components for automatic handling)
- ⑬. The reinforcing collar is wrapped around the emboss tape and taped down at the end of the collar.
- ⑭. Some of the pockets may have a different shape.

HRS	DRAWING NO.	EDC-403740-51-00
	PART NO.	DF40TC (3.0)-10DP-0.4V (51)
	CODE NO.	GL0684-0033-0-51
		2/3

△ Note deleted.

Mar.1.2026 Copyright 2026 HIROSE ELECTRIC CO., LTD. All Rights Reserved.
In case of consideration for using Automotive equipment / device which demand high reliability, kindly contact our sales window correspondents.

15. Please refer to the product guideline ETAD-H1015 for detail of connector handling.

The position between the connector and PAD

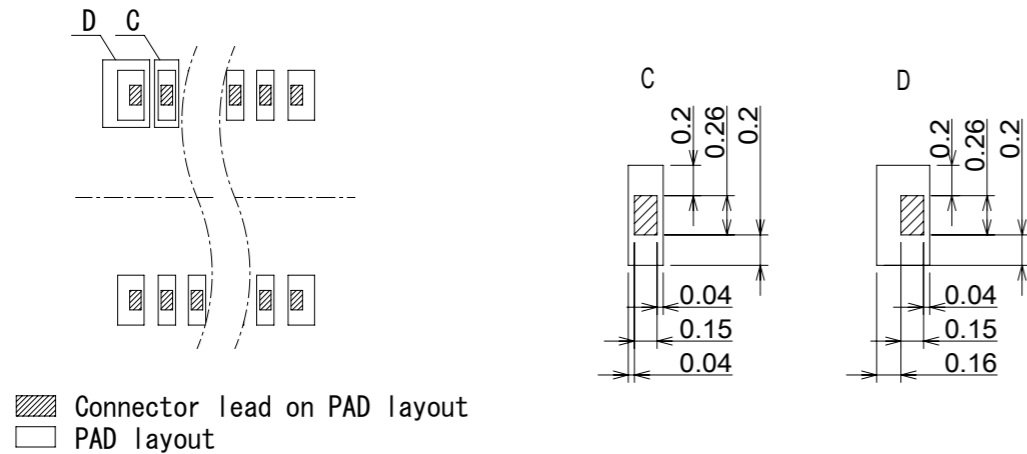

Un-mating method

Please un-mate the connector by hand

- (1) Un-mate the connectors parallel to each other. However, if the connectors have high pin counts or thinner FPC and stiffener, it becomes more difficult to do so.

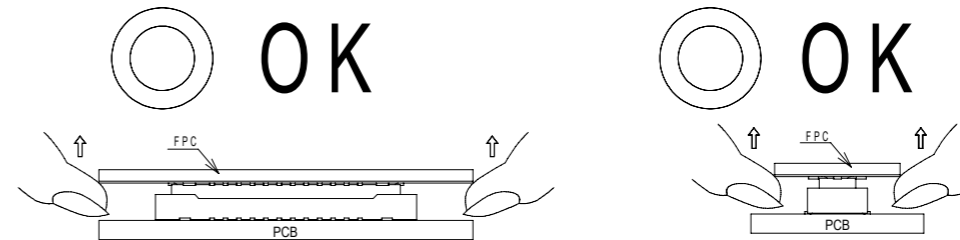

Mating method

Please mate the connector by hand.

Mating procedure

- (1) Find the alignment area to the connector in the appropriate mating position. This connector has an alignment chamber (guidance ribs) on receptacle side and "R" on plug side, so that the connector will be self-aligned. When the connector comes to the appropriate position, the connector goes into the aligned position. When aligned, it can be felt by hand.

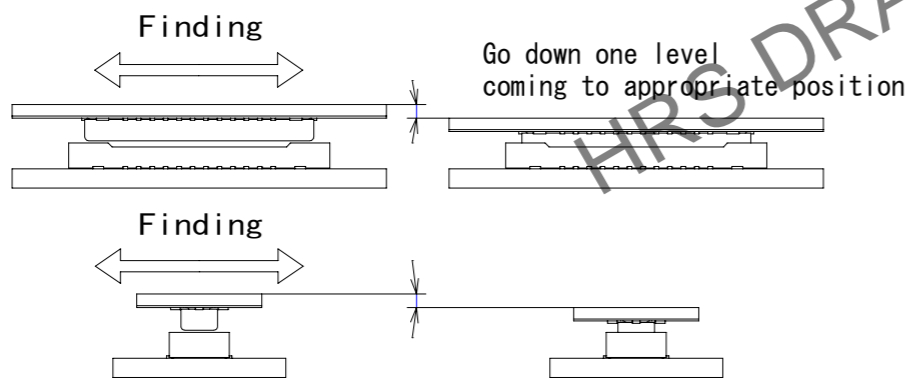

- (2) When guiding, the connectors are aligned parallel to each other, with longitudinal and lateral movements restricted. Mate them properly by applying force in this condition.



- (3) Make sure the connectors are mated correctly. If one side is floating or the connectors are mated in one direction, un-mate them once, and then mate them again, following the procedures above from the beginning.

- (2) If the connector cannot be un-mated parallel it can be removed diagonally from the pitch direction. Be careful to do so since this action applies stress on the contact.

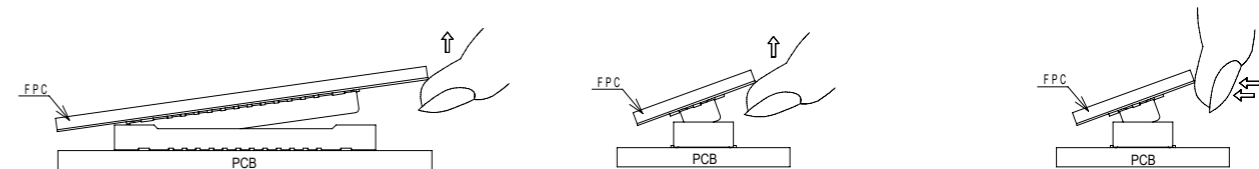

- (3) If the FPC is not rigid, the connector can be broken. Please check the action of the FPC to be used repeatedly at the time of trial production. Be careful to un-mate them from the pitch direction, pulling it from the corner can also risk to putting stress on contacts.

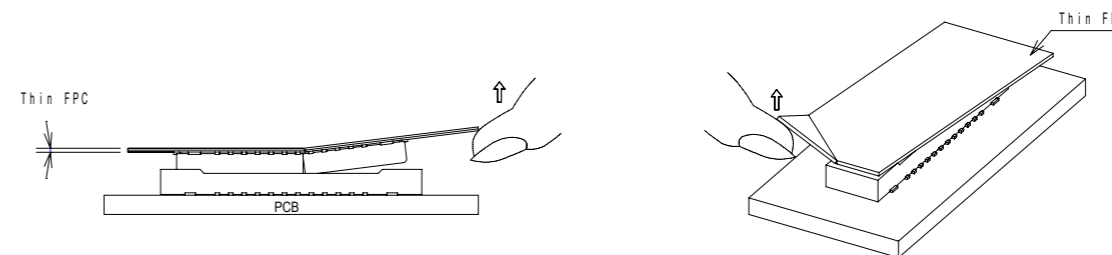

HRS	DRAWING NO.	EDC-403740-51-00	3/3
	PART NO.	DF40TC (3.0)-10DP-0.4V (51)	
	CODE NO.	GL0684-0033-0-51	
	Note deleted.		