

Oct.1.2024 Copyright 2024 HIROSE ELECTRIC CO., LTD. All Rights Reserved.  
 In case of consideration for using Automotive equipment / device which demand high reliability, kindly contact our sales window correspondents.

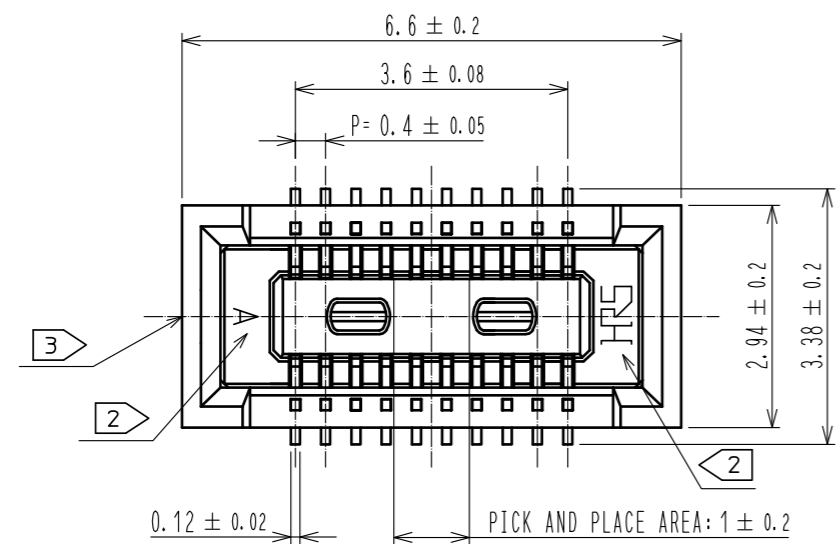

RECOMMENDED PATTERN

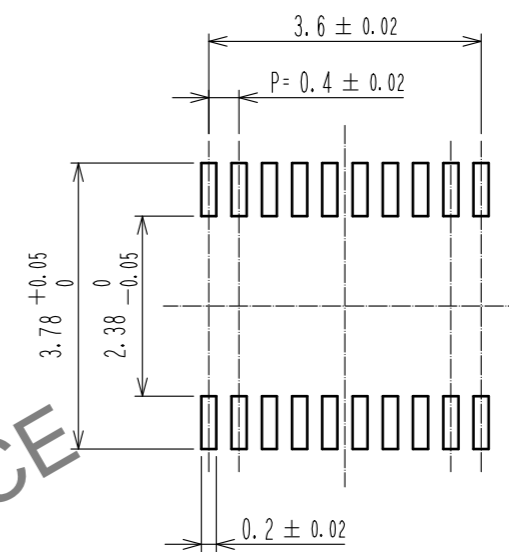

RECOMMENDED METAL MASK THICKNESS : 120 μm  
 RECOMMENDED METAL MASK OPENING RATIO : 80% FOR LEAD PAD

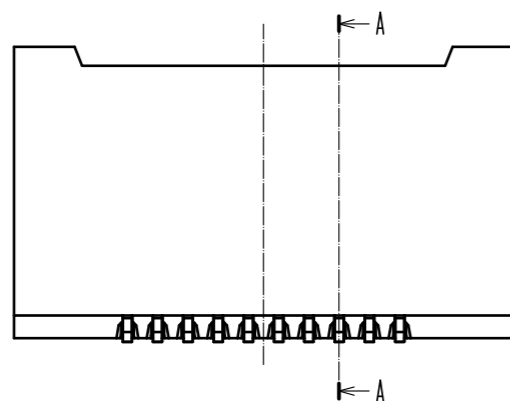

ENGAGEMENT FIGURE (20:1)

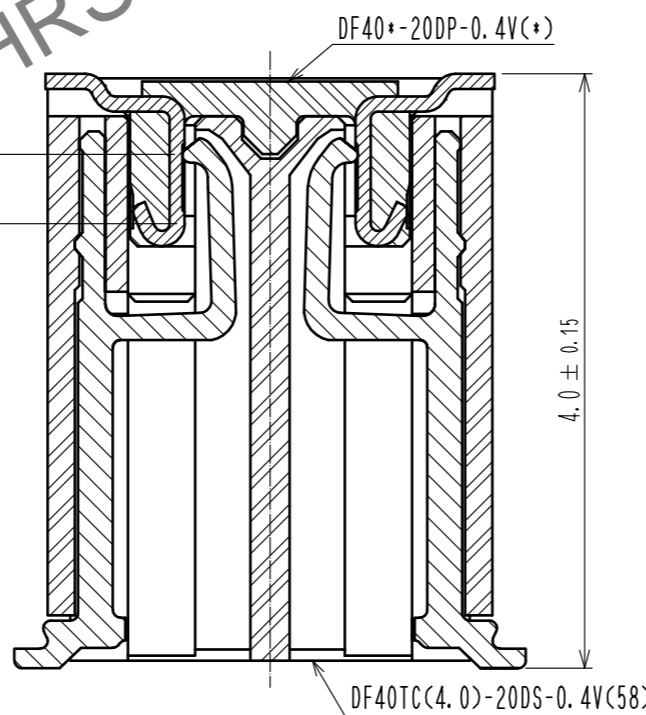

- NOTES ) 1. ALL LEADS CO-PLANARITY SHALL BE 0.1 MAX.  
 2. HRS MARK AND CAV NO. ARE LOCATED IN APPROXIMAL AREA.  
 3. GATE IS COCATED IN APPROXIMAL AREA.

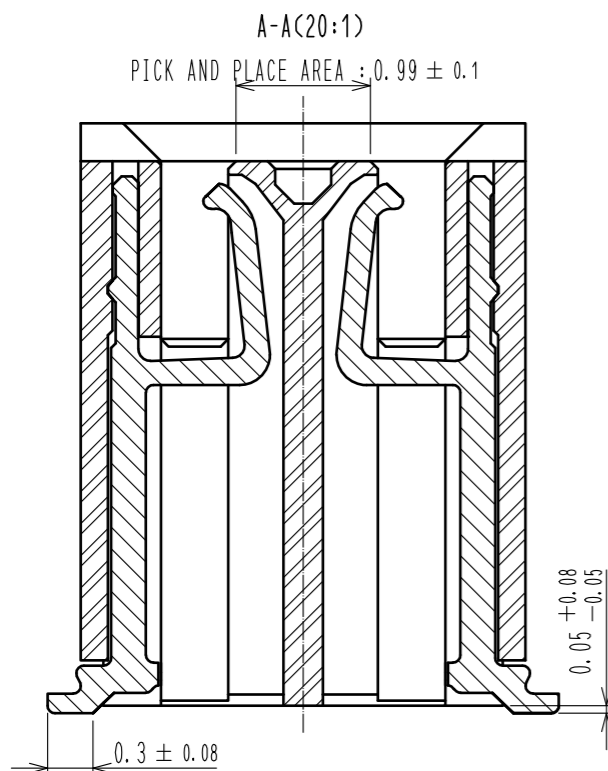

2	COPPER ALLOY	CONTACT AREA:GOLD 0.05 μm MIN SMT LEAD:GOLD 0.05 μm MIN UNDERPLATING:NICKEL 1 μm MIN	6	PS	CLEAR, REINFORCEMENT COLLAR
			5	PS	BLACK
			4	POLYESTER	CLEAR, COVER TAPE
1	LCP	BLACK, UL94V-0	3	PS	CLEAR, EMBOSSED CARRIER TAPE
NO.	MATERIAL	FINISH . REMARKS	NO.	MATERIAL	FINISH . REMARKS
UNITS	⊙	SCALE	COUNT	DESCRIPTION OF REVISIONS	
mm		10:1	0	DESIGNED	CHECKED
HIROSE ELECTRIC CO., LTD.		APPROVED : WR. FUKUCHI	20210402	DRAWING NO. EDC-386373-58-00	
		CHECED : TS. MIYAZAKI	20210402	PART NO. DF40TC(4.0)-20DS-0.4V(58)	
		DESIGNED : YK. SATAKE	20210402	CODE NO. CL0684-4258-0-58	
		DRAWN : YK. SATAKE	20210402	1/2	

Oct.1.2024 Copyright 2024 HIROSE ELECTRIC CO., LTD. All Rights Reserved.  
 In case of consideration for using Automotive equipment / device which demand high reliability, kindly contact our sales window correspondents.

# EMBOSSED CARRIER TAPE PACKAGING (FREE)

# STYLE AND DIMENSION OF REEL (FREE)

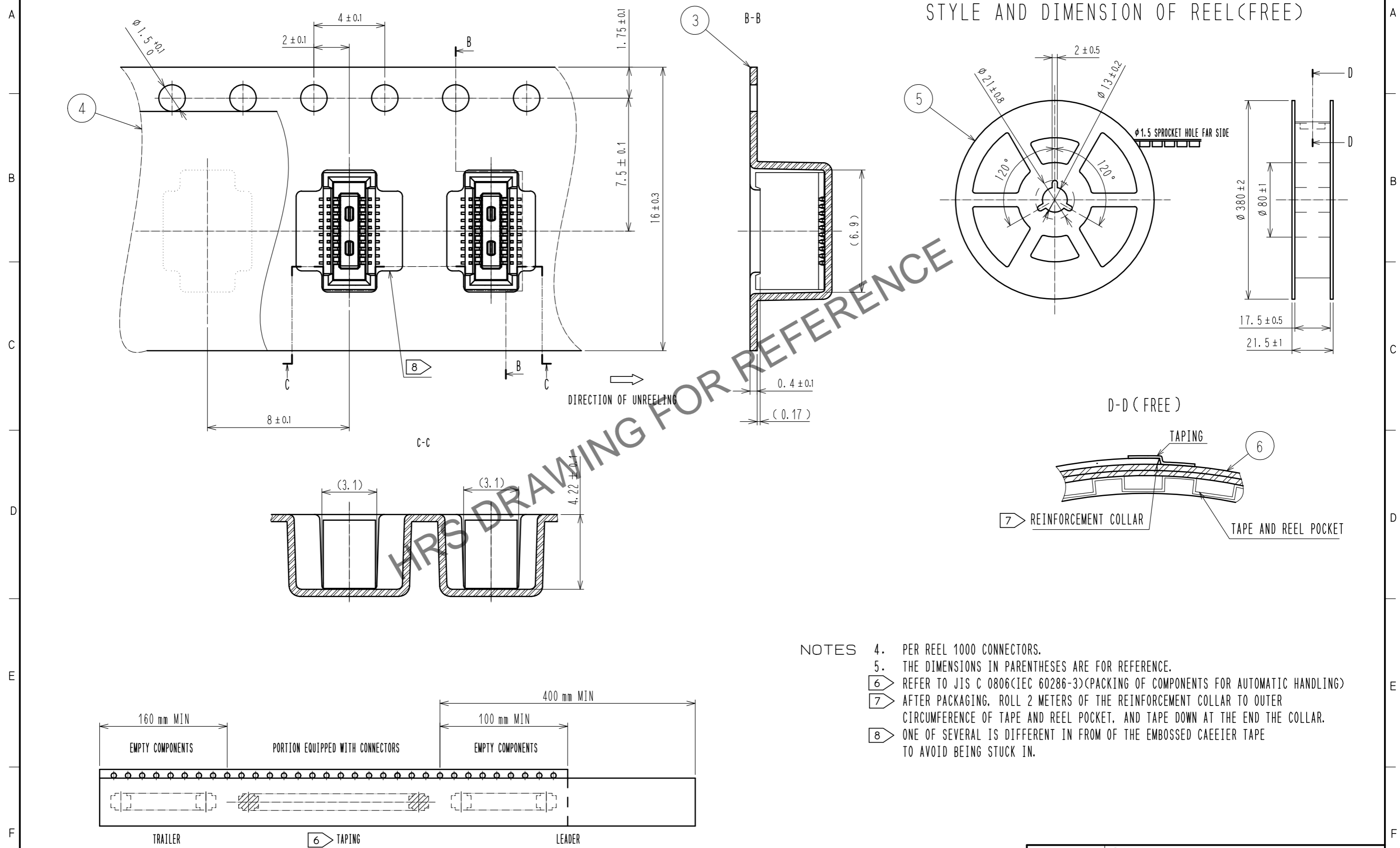

- NOTES
- 4. PER REEL 1000 CONNECTORS.
  - 5. THE DIMENSIONS IN PARENTHESES ARE FOR REFERENCE.
  - 6 REFER TO JIS C 0806(IEC 60286-3)(PACKING OF COMPONENTS FOR AUTOMATIC HANDLING)
  - 7 AFTER PACKAGING, ROLL 2 METERS OF THE REINFORCEMENT COLLAR TO OUTER CIRCUMFERENCE OF TAPE AND REEL POCKET, AND TAPE DOWN AT THE END THE COLLAR.
  - 8 ONE OF SEVERAL IS DIFFERENT IN FROM OF THE EMBOSSED CARRIER TAPE TO AVOID BEING STUCK IN.

<b>HRS</b>	DRAWING NO.	EDC-386373-58-00	
	PART NO.	DF40TC(4.0)-20DS-0.4V(58)	
	CODE NO.	CL0684-4258-0-58	2/2